

REV	DATE	DRAWN/CHKD	DESCRIPTION	PART NUMBER	COLOR	G	
						MIN	MAX
				NY-CC-200-10	WHITE		
				NY-CC-200-20	BLACK	.014	.103
				NY-CC-300-10	WHITE		
				NY-CC-300-20	BLACK	.048	.137
				NY-CC-400-10	WHITE		
				NY-CC-400-20	BLACK	.112	.201

INCHES

ALL DIMENSIONS WITHOUT TOLERANCES ARE FOR REFERENCE ONLY.

THIRD ANGLE PROJECTION

A PAPER SIZE

NOTES:

A. MATERIAL:

- STRAP: 6/6 NYLON
- PANEL FASTENER: NYLON AND POLYCARBONATE

B. ONE STRAP HOLE MOVEMENT CHANGES THE LOOP DIAMETER BY .125.

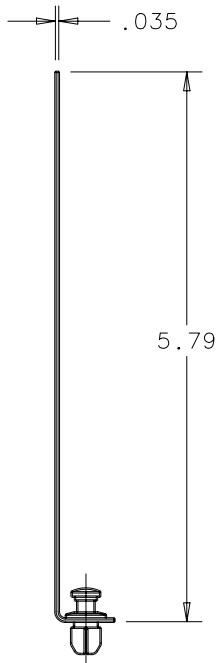

SCALE: 1/2

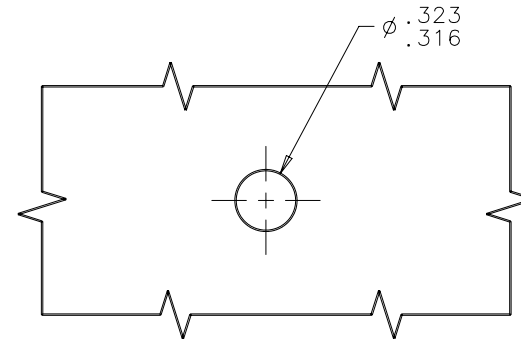
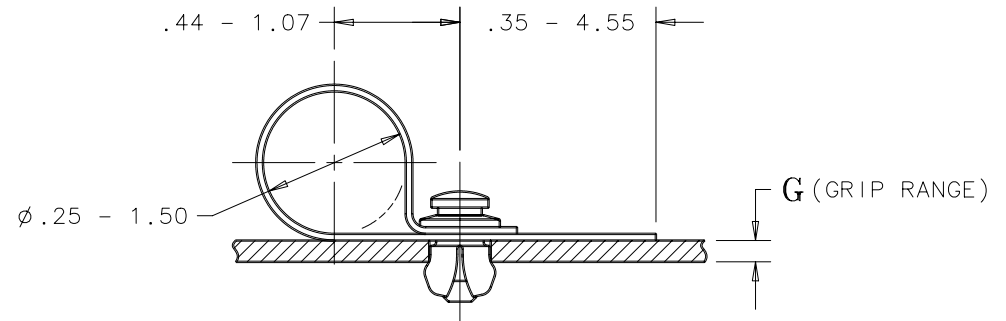
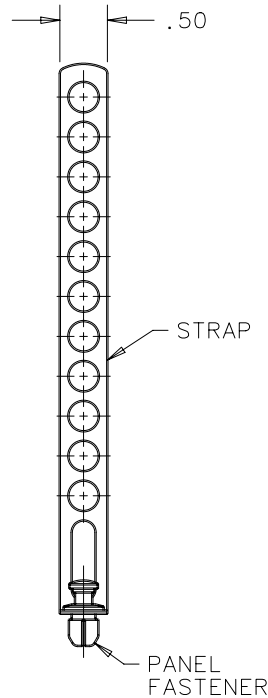

PANEL PREPARATION