



KEEPER PLATE - CONCEALED

DATE	DRAWN	CHKD	SCALE	DRAWING NUMBER
15FEB77	T M		1 : 1	J-K3-1617

REV.	DATE	BY-CHKD	REVISIONS	PART NUMBER	MATERIAL	FINISH			
A	13NOV95	PCB CHW	PRN: K3-89	K3-1617-XX	CARBON STEEL	SEE NOTE "A"			
				K3-1617-52	STAINLESS STEEL	NATURAL			
				K3-1617-55	STAINLESS STEEL	BLACK OXIDE			

NOTE "A" : FINISHES (-XX)

- 07 : ZINC PLATE, BRIGHT CHROMATE DIP
- 08 : ZINC PLATE, YELLOW CHROMATE DIP
- 12 : ZINC PLATE, OLIVE DRAB CHROMATE DIP
- 82 : NICKLE PLATE PLUS ZINC PLATE, BLACK CHROMATE

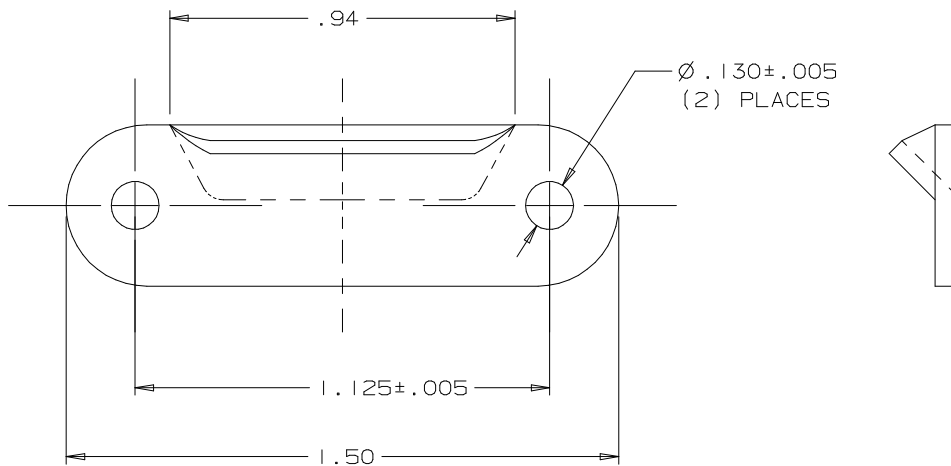
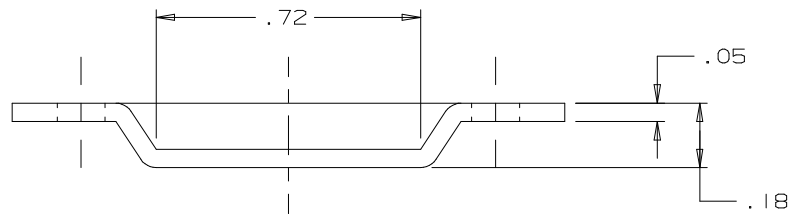

FORMAT A 1 MAR 94

PROPRIETARY ITEM - EXCEPT FOR USES EXPRESSLY GRANTED IN WRITING INFORMATION DISCLOSED HEREON IS CONFIDENTIAL AND ALL RIGHTS PATENT AND OTHERWISE ARE RESERVED BY SOUTHCO, INC.

*DIMENSIONS IN INCHES
THIRD ANGLE PROJECTION*

DIMENSIONS WITHOUT TOLERANCES ARE FOR REFERENCE ONLY.

DRAWING NUMBER
J-K3-1617