

REVISION HISTORY			
REV	DATE	BY	DESCRIPTION
F	17JUL2017	SPD/YGC	PRN: P2017-1737

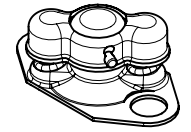

SCALE 1:1

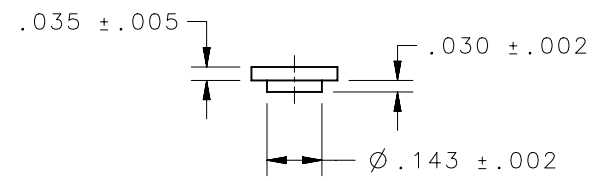
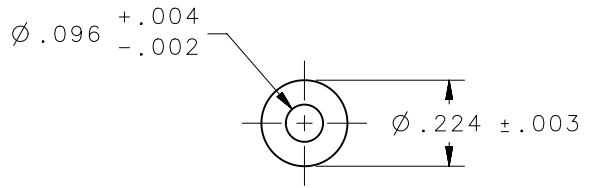
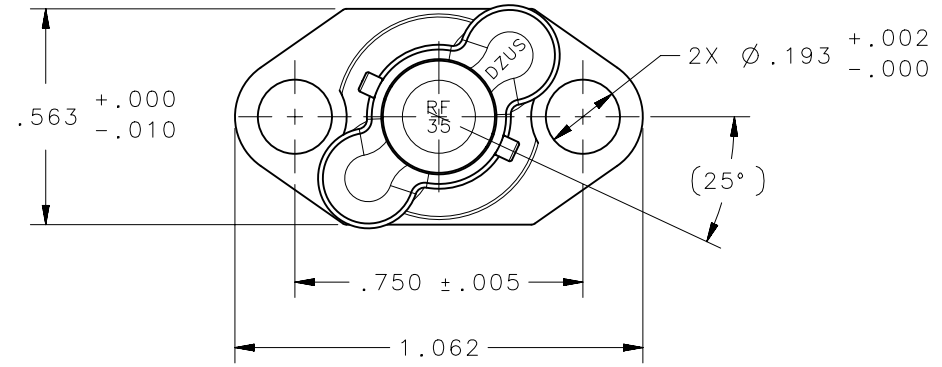

SPACER  
SEE NOTES 3 AND 4

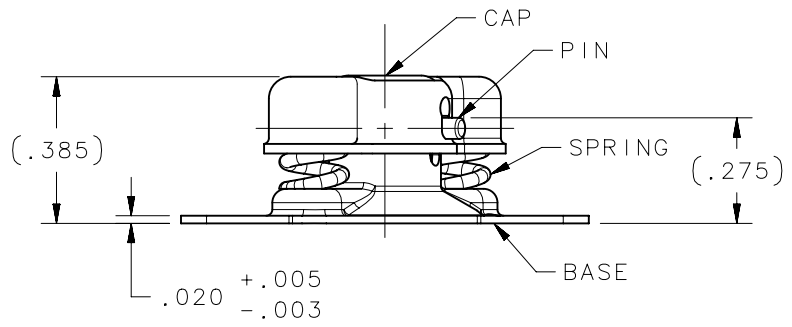

NOTES:

- REMOVE ALL BURRS AND BREAK SHARP CORNERS.
- ALL CORNERS AND FILLETS R.005 MAX.
- MATERIAL :  
CAP:1008/1010 STEEL PER ASTM A109/A109M.  
SPRING:MUSIC WIRE PER ASTM A228  
PIN:MUSIC WIRE PER ASTM A228  
BASE:4130 STEEL, HEAT TREAT TO ROCKWELL C37-40.  
SPACER:C11L17, 12L14, STEEL
- FINISH:SEE J-D5-0-3 FOR FINISH INFORMATION.

2350-18F-C3C	RF35CBC	D4-RF35CBCNA
2350-18F-C3Y	RF35CBY	D4-RF35CBYNA
2350-18F-Z3CT	RF35ZCT	D4-RF35ZCTNA
2350-18F-Z3YT	RF35ZYT	D4-RF35ZYTNA
DFCI PART NUMBER	DZUS PART NUMBER	SOUTHCO PART NUMBER

CAGE CODE	72794	THIRD ANGLE PROJECTION	
		INCHES [MM]	
		TOLERANCES UNLESS OTHERWISE NOTED	
		X° ..... ±2°	
		X/X ..... ±1/32	
		.XX ..... ±.015	
		.XXX ..... ±.010	
PROPRIETARY ITEM		PER ASME Y14.5M-1994	
EXCEPT FOR USES EXPRESSLY GRANTED IN WRITING, INFORMATION DISCLOSED HEREON IS CONFIDENTIAL AND ALL RIGHTS, PATENT AND OTHERWISE, ARE RESERVED BY SOUTHCO, INC.			

<b>southco</b> <sup>®</sup>			
CONNECT • CREATE • INNOVATE			
DESCRIPTION RECEPTACLE ASSEMBLY			
SIZE	SYSTEM	DWG NO.	
A	NX	J-D4-RF35NA	
DRAWN BY	DATE	SCALE	SHEET
CMS/NJF	04JUN2015	2:1	1 OF 1