



ST-8P Hinge

Position control · Constant torque

- Designed for overmolding
- Brings constant torque performance to a wide range of applications
- Space efficient design provides high torque in minimum space
- Never requires adjustment

Material and Finish

Aluminum, plastic and hardened steel

Performance Details

Cycle performance:
20,000 cycles within $\pm 20\%$ of static torque specification

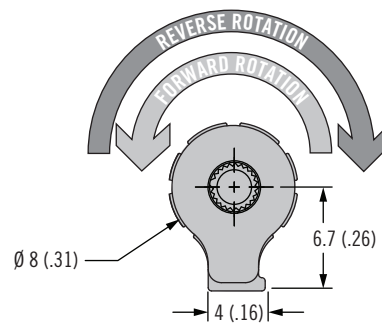
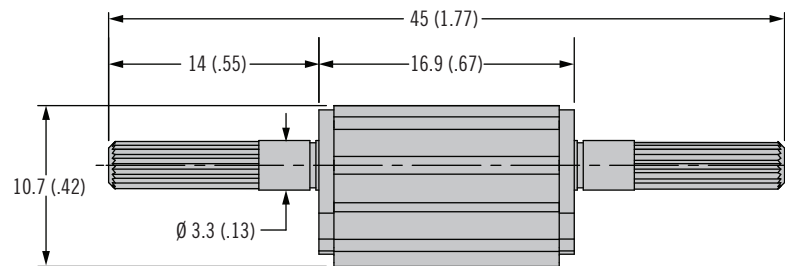

Part Number

See table

Symmetric Torque Versions	
Part Number	Static Torque (Forward and Reverse) N·m (in·lbf)
ST-8P-40SA-50	0.45 (4)
ST-8P-60SA-50	0.68 (6)
ST-8P-80SA-50	0.9 (8)

Asymmetric Torque Versions		
Part Number	Static Torque N·m (in·lbf)	
	Forward N·m (in·lbf)	Reverse N·m (in·lbf)
ST-8P-40FA-50	0.45 (4.0)	0.27 (2.4)
ST-8P-60FA-50	0.68 (6.0)	0.41 (3.6)
ST-8P-80FA-50	0.90 (8.0)	0.54 (4.8)
ST-8P-100FA-50	1.13 (10.0)	0.68 (6)
ST-8P-40RA-50	0.27 (2.4)	0.45 (4)
ST-8P-60RA-50	0.41 (3.6)	0.68 (6)
ST-8P-80RA-50	0.54 (4.8)	0.9 (8)
ST-8P-100RA-50	0.68 (6.0)	1.13 (10)

Other options available. For complete details on variety, part numbers, installation and specification, go to



www.southco.com/ST2

Dimensions in millimeters (inch) unless otherwise stated

southco
CONNECT · CREATE · INNOVATE

ST-11P Hinge

Position control · Constant torque

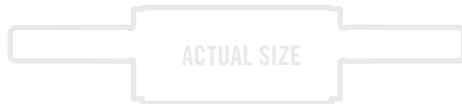
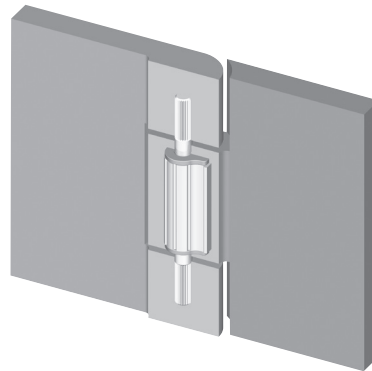
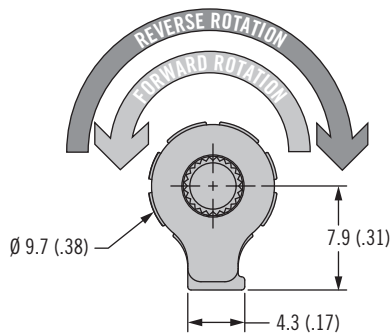
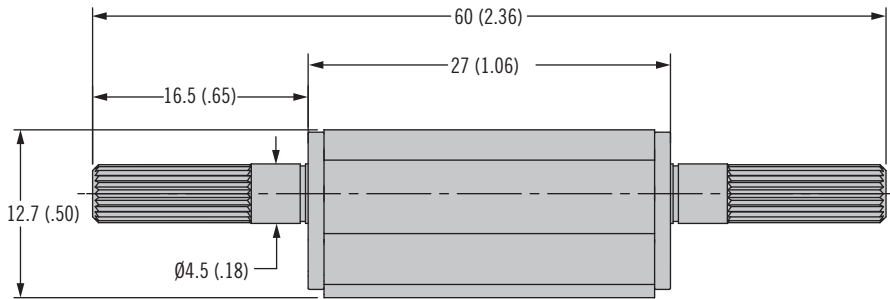

- Designed for overmolding
- Brings constant torque performance to a wide range of applications
- Space efficient design provides high torque in minimum space
- Never requires adjustment

Material and Finish

Aluminum, plastic and hardened steel

Performance Details

Cycle performance:
20,000 cycles within $\pm 20\%$ of static torque specification

Part Number

See table

Symmetric Torque Versions	
Part Number	Static Torque (Forward and Reverse) N·m (in·lbf)
ST-11P-140SA-50	1.58 (14)
ST-11P-200SA-50	2.26 (20)
ST-11P-260SA-50	2.9 (26)

Asymmetric Torque Versions		
Part Number	Static Torque N·m (in·lbf)	
	Forward N·m (in·lbf)	Reverse N·m (in·lbf)
ST-11P-140FA-50	1.58 (14)	0.95 (8.4)
ST-11P-200FA-50	2.26 (20)	1.36 (12)
ST-11P-260FA-50	2.94 (26)	1.76 (15.6)
ST-11P-320FA-50	3.62 (32)	2.17 (19.2)
ST-11P-140RA-50	0.95 (8.4)	1.58 (14)
ST-11P-200RA-50	1.36 (12)	2.26 (20)
ST-11P-260RA-50	1.76 (15.6)	2.94 (26)
ST-11P-320RA-50	2.17 (19.2)	3.62 (32)