



SC Self Contained Electronic Locking System

Electronic access (RFID Version)

- No wiring required
- Battery Operated (3 AA)
- Accepts *MIFARE*® Classic, *MIFARE*® Plus, *MIFARE*® DESFire® and *HID*® smart cards**
- Up to 20 unique user cards or user keys per lock
- Vertical or Horizontal user orientation
- Manager key with 9V battery for electrical override

Material & Finish

Housing, Trim Plate, Mounting Cup: PC/ABS, Flammability rating: UL94-V0
 Knob: Zinc alloy, powder coated
 Screw, Snap Ring: Steel



Custom colors available - Contact Southco for Details

Part Number Selection

Order latch and cam separately
 For cam see page 22

Note: Detailed instructions regarding system set-up and operation are included with each latch assembly.

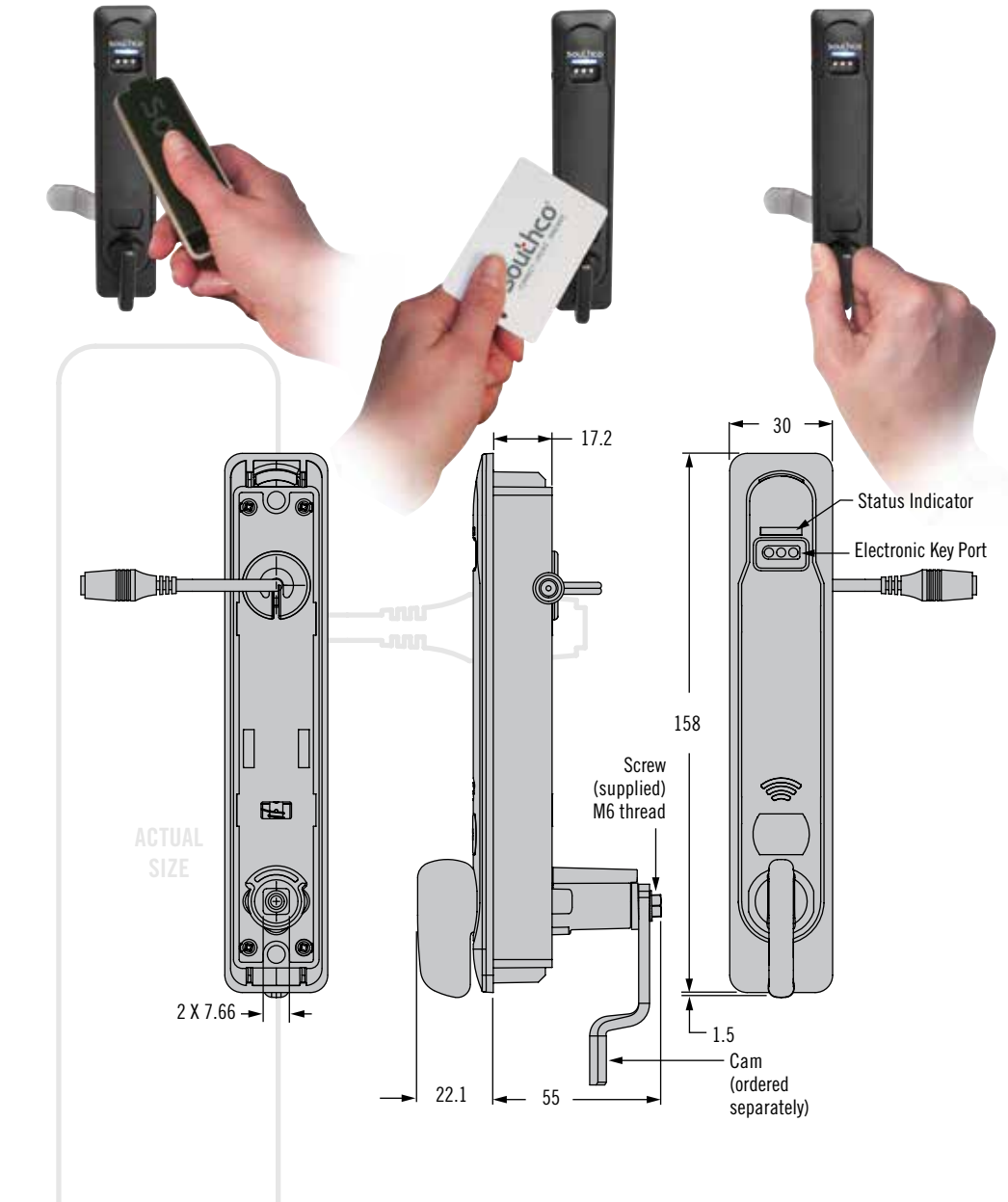

Latch Assembly Part Number (no cam)

SC - 20 - 100 D - 10*

D Door Thickness Range

- 0 1 - 15 (0.04 - 0.59)
- 1 15 - 25 (0.60 - 0.98)

***Note:** Remove '10' for latch without Southco logo.

** *MIFARE* Classic, *MIFARE* Plus, *MIFARE* DESFire are trademarks of NXP B.V.

HID is a registered trademark of HID Global Corp.

D Door Thickness			
	Door Thickness Range	Mounting Screw ¹ M5 X 0.8 thread	Cup Height see page 22
D = 0	1 - 10 (0.04 - 0.39)	Short	20 (.8)
	10 - 15 (0.40 - 0.59)	Long	
D = 1	15 - 20 (0.60 - 0.79)	Short	8 (.3)
	20 - 25 (0.80 - 0.98)	Long	

1Note: Two short and two long mounting screws are provided with each latch assembly.

Cams, RFID cards, and keys ordered separately.

Other options available. For complete details on variety, part numbers, installation and specification, go to



www.southco.com/SC

Dimensions in millimeters (inch) unless otherwise stated

SC Self Contained Electronic Locking System

Electronic access (Keypad Version)

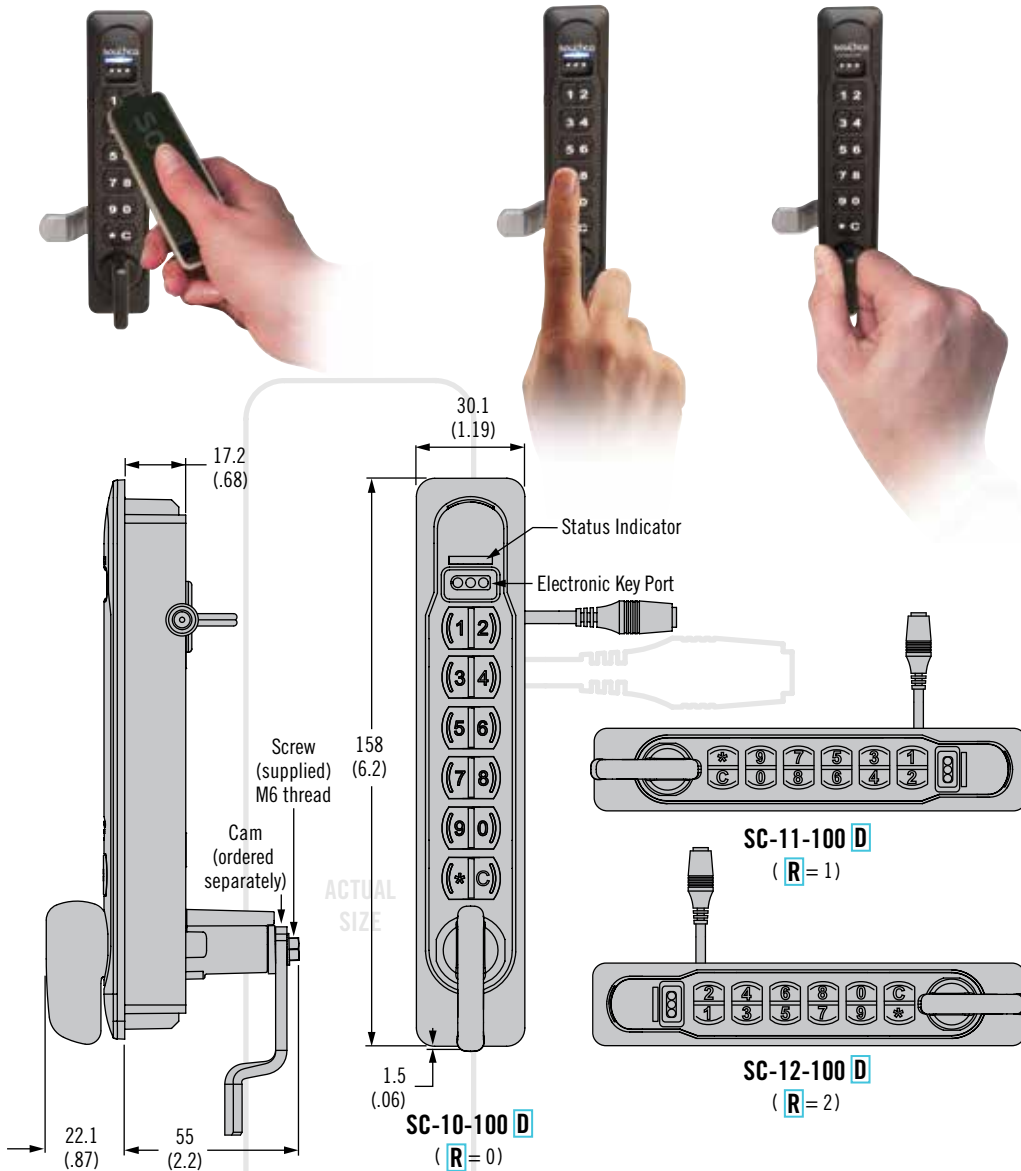

- Simple Keypad Access
- Battery Operated (3 AA)
- Up to 20 unique user codes of any combination; user keys or PINs
- Vertical or Horizontal orientation (specify when ordering)
- Custom colors and logos available
- Manager key with 9V battery for electrical override
- Rod systems available for multi-point latching

Material & Finish

Housing, Trim Plate, Mounting Cup: PC/ABS, Flammability rating: UL94-V0
 Knob: Zinc alloy, powder coated
 Screw, Snap Ring: Steel



Custom colors available - Contact Southco for Details

Latch Assembly Part Number (no cam)

- D** Door Thickness Range
- 0 1 - 15 (0.04 - 0.59)
 - 1 15 - 25 (0.60 - 0.98)

SC - T R - 100 D - 10*

- T** Type
- 1 Key managed
 - 5 Code managed
- R** Orientation
- 0 Vertical
 - 1 Horizontal, knob left
 - 2 Horizontal, knob right

*Note: Remove '10' for latch without Southco logo.

D Door Thickness			
	Door Thickness Range	Mounting Screw ¹ M5 X 0.8 thread	Cup Height see page 22
D = 0	1 - 10 (0.04 - 0.39)	Short	20 (.8)
	10 - 15 (0.40 - 0.59)	Long	
D = 1	15 - 20 (0.60 - 0.79)	Short	8 (.3)
	20 - 25 (0.80 - 0.98)	Long	

¹Note: Two short and two long mounting screws are provided with each latch assembly.
 Cams and keys ordered separately.

Part Number Selection

Order latch and cam separately
 For cam see page 22

Note: Detailed instructions regarding system set-up and operation are included with each latch assembly.





SC Self Contained Electronic Locking System

Electronic access

How to Order

- Select Latch Assembly
- Determine grip
- Order cam separately based on grip dimension
- Order one programming key per site (Not required for code managed keypad)
- Order manager keys as needed*
- Order RFID cards, labels or User keys as needed
- Note: Battery box included
- Requires 3 AA Batteries (Not Included)

Cam Part Numbers (Order Separately)	
Cam Part Number	GRIP mm(in)
SC-5000	42.5 (1.67)
SC-5002	40.5 (1.59)
SC-5004	38.5 (1.52)
SC-5006	36.5 (1.44)
SC-5008	34.5 (1.36)
SC-5010	32.5 (1.28)
SC-5012	30.5 (1.20)
SC-5014	28.5 (1.12)
SC-5016	26.5 (1.04)
SC-5018	24.5 (.96)
SC-5020	22.5 (.89)
SC-5022	20.5 (.81)
SC-5024	18.5 (.73)
SC-5026	16.5 (.65)
SC-5028	14.5 (.57)
SC-5030	12.5 (.49)
SC-5032	10.5 (.41)
SC-5034	8.5 (.33)
SC-5036	6.5 (.26)
SC-5038	4.5 (.18)
SC-5040	2.5 (.10)
SC-5042	0.5 (.02)

*For code managed keypad, manager key only needed for electrical override.

Installation

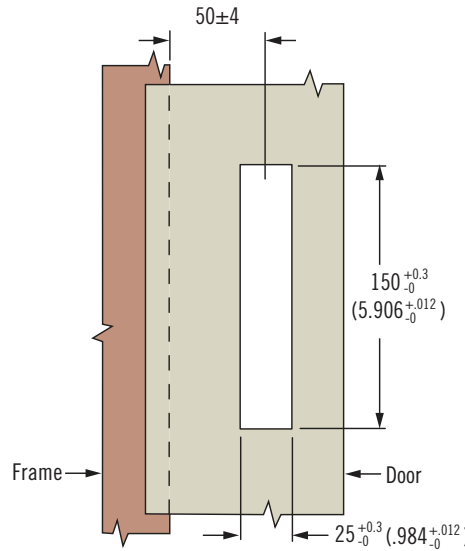

Grip Measurement

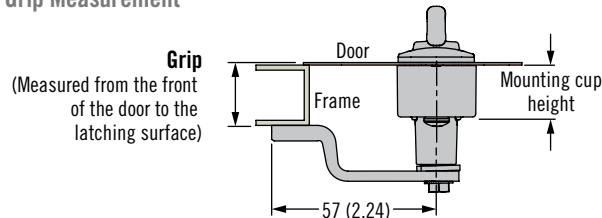

Battery Box

(Mount inside the door, included with each latch assembly)

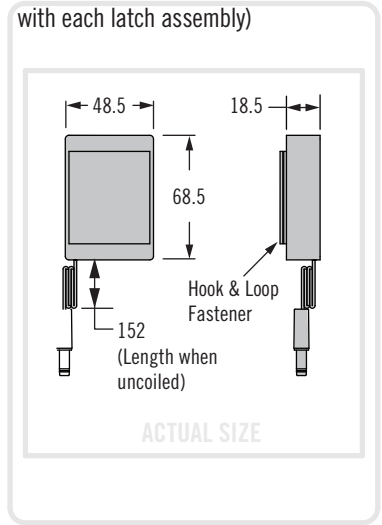

Electronic Key Part Numbers (Order Separately)			
Part Number	Description		
SC-A10-10	Programming Key	Used to enroll Manager keys and for Express Registration	
SC-A20-10	Manager Key	Used to enroll User Codes, User Keys and RFID cards. Also provides electrical override.*	
SC-A30-10	User Key	Provides quick one touch access	

Note: Contact Southco for custom color/ logo options.

RFID Card and Label Part Numbers (Order Separately)	
Part Number	Description
EA-C3-101-9	Card, RFID, 13.56MHz, MIFARE® Classic, 0.8 (.03) Thick, Slot, Logo**
EA-C3-300-9	Label, RFID, MIFARE® Classic, 4 BYTE UID (Ø28mm, .2mm thick)

Note: Detailed instructions regarding system set-up and operation are included with each latch assembly.
 ** MIFARE and MIFARE Classic are trademarks of NXP B.V.

