

REVISION HISTORY			
REV	DATE	BY	DESCRIPTION
C	29SEP2016	DMS/YGC	PRN: P2016-2248

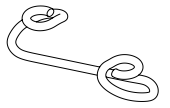

SCALE 1:1

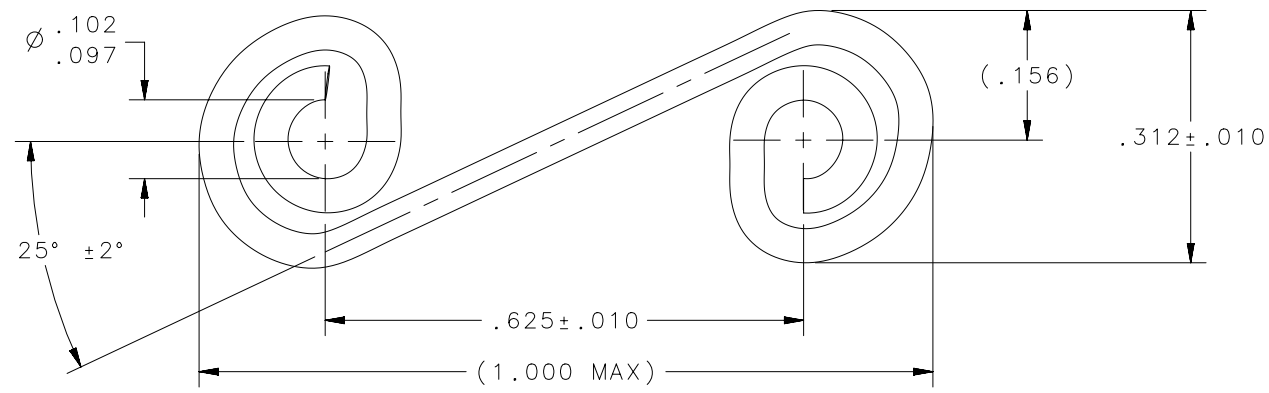

-XXX	DIMENSION "H"
-125	.125
-150	.150
-175	.175
-200	.200
-225	.225
-250	.250

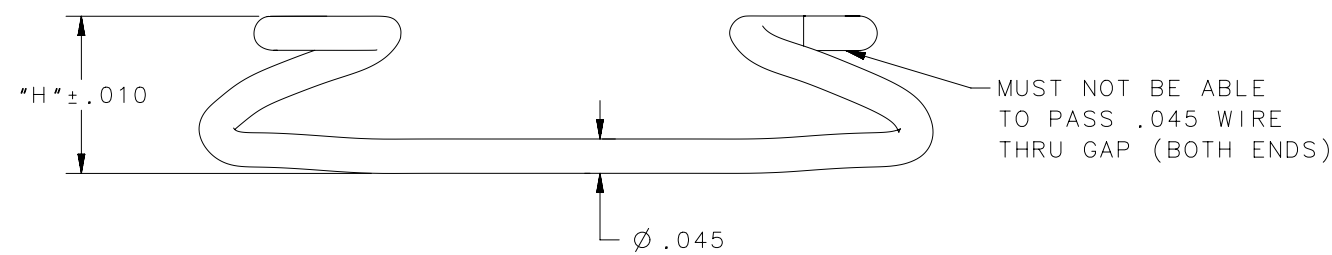



- NOTES:
- A. REMOVE ALL BURRS AND BREAK SHARP CORNERS.
 - B. ALL CORNERS AND FILLETS R.005 MAX.
 - C. FOR FINISH INFORMATION, PLEASE SEE J-D5-0-3.
 - D. SEE SHEET 2 FOR ADDITIONAL PART NUMBERS.

D4-S3-XXXSSNA		316 STAINLESS STEEL		SEE NOTE C		
D4-S3-XXXXYYNA		MUSIC WIRE PER ASTM-A228		SEE NOTE C		
SOUTHCO PART NUMBER		MATERIAL		FINISH		
CAGE CODE	72794	THIRD ANGLE PROJECTION	 southco [®] CONNECT • CREATE • INNOVATE			
		INCHES [MM]				
PROPRIETARY ITEM		TOLERANCES UNLESS OTHERWISE NOTED		DESCRIPTION		
EXCEPT FOR USES EXPRESSLY GRANTED IN WRITING, INFORMATION DISCLOSED HEREON IS CONFIDENTIAL AND ALL RIGHTS, PATENT AND OTHERWISE, ARE RESERVED BY SOUTHCO, INC.		X° ±1/2°		SIZE A		
		X/X ±1/64				
		.XX ±.010		SYSTEM NX		
		.XXX ±.005		DWG NO. J-D4-S3-XXXNA		
PER ASME Y14.5M-1994		DRAWN BY CMS/NJF		DATE 04JUN2015	SCALE 4:1	
				SHEET 1 OF 2		

REVISION HISTORY			
REV	DATE	BY	DESCRIPTION
C	29SEP2016	DMS/YGC	PRN: P2016-2248

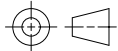
DFCI PART NUMBER	DZUS PART NUMBER	SOUTHCO PART NUMER
1219-3125-SS	S3-125SS	D4-S3-125SSNA
1219-3125-Z3CT	S3-125ZCT	D4-S3-125ZCTNA
1219-3150-C3C	S3-150CBC	D4-S3-150CBCNA
1219-3150-C3Y	S3-150CBY	D4-S3-150CBYNA
1219-3150-SS	S3-150SS	D4-S3-150SSNA
1219-3150-SS-PAS	S3-150SSPS	D4-S3-150SSPSNA
1219-3150-Z3CT	S3-150ZCT	D4-S3-150ZCTNA
1219-3150-Z3Y	S3-150ZBY	D4-S3-150ZYTNA
1219-3150-Z3YT	S3-150ZYT	D4-S3-150ZYT
1219-3175-C3Y	S3-175CBY	D4-S3-175CBYNA
1219-3175-SS	S3-175SS	D4-S3-175SSNA
1219-3175-SS-PAS	S3-175SSPS	D4-S3-175SSPSNA
1219-3175-Z3CT	S3-175	D4-S3-175ZCTNA
1219-3175-Z3Y	S3-175ZBY	D4-S3-175ZBYNA
1219-3200-Z3YT	S3-200ZYT	D4-S3-200ZYTNA
1219-3200-SS	S3-200SS	D4-S3-200SSNA
1219-3200-SS-PAS	S3-200SSPS	D4-S3-200SSPSNA
1219-3200-Z3CT	S3-200	D4-S3-200ZCTNA
1219-3225-Z3Y	S3-225ZBY	D4-S3-225ZBYNA
1219-3225-SS	S3-225SS	D4-S3-225SSNA
1219-3225-Z3CT	S3-225	D4-S3-225ZCTNA
1219-3250-Z3Y	S3-250ZBY	D4-S3-250ZBYNA

CAGE CODE 72794		THIRD ANGLE PROJECTION 	 CONNECT • CREATE • INNOVATE		
		INCHES [MM]			
		TOLERANCES UNLESS OTHERWISE NOTED	SIZE SYSTEM DWG NO.		
<small>PROPRIETARY ITEM EXCEPT FOR USES EXPRESSLY GRANTED IN WRITING, INFORMATION DISCLOSED HEREON IS CONFIDENTIAL AND ALL RIGHTS, PATENT AND OTHERWISE, ARE RESERVED BY SOUTHCO, INC.</small>		X° ±1/2° X/X ±1/64 .XX ±.010 .XXX ±.005	A	NX	J-D4-S3-XXXNA
		PER ASME Y14.5M-1994	DRAWN BY CMS/NJF	DATE 04JUN2015	SCALE 1:1 SHEET 2 OF 2