



NUMBER E5 PULL TAB

DATE	DRAWN	CHKD	SCALE	DRAWING NUMBER
17JUN98	MMM		FULL	J-E5-18

REV.	DATE	REV	REVISIONS	PART NUMBER	MATERIAL	FINISH			
				E5-18	NYLON	BLACK			

NOTES :
 1) WHEN USING PULL TAB, MINIMUM AND MAXIMUM GRIPS OF LATCHES ARE REDUCED BY 2.4 mm

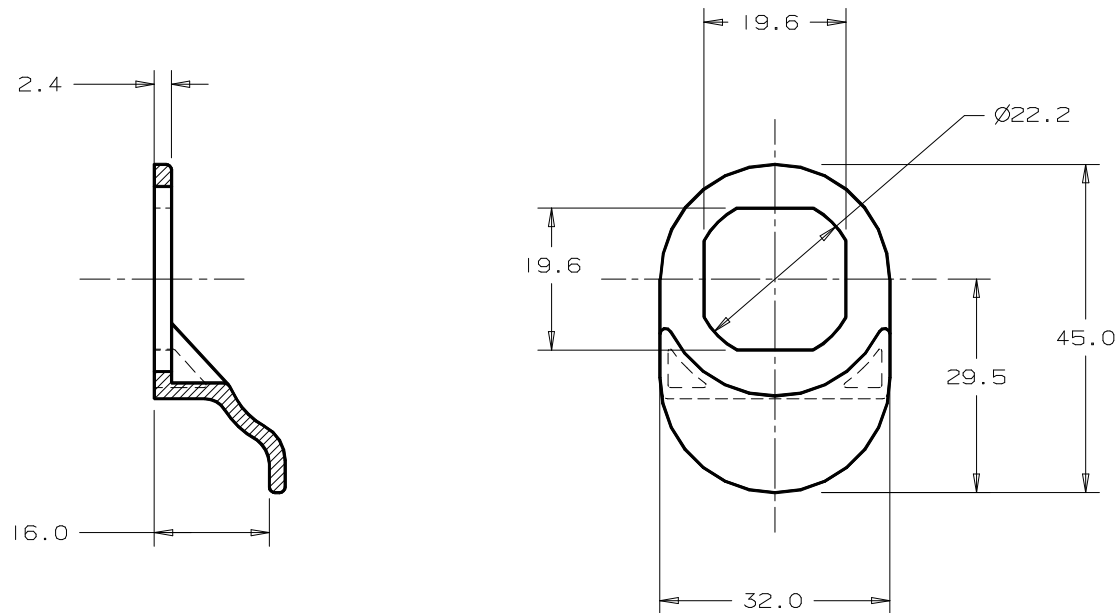

FORMATA 3/88

PROPRIETARY ITEM - EXCEPT FOR USES EXPRESSLY GRANTED IN WRITING INFORMATION DISCLOSED HEREON IS CONFIDENTIAL AND ALL RIGHTS PATENT AND OTHERWISE ARE RESERVED BY SOUTHCO, INC.

DIMENSIONS IN MILLIMETERS
THIRD ANGLE PROJECTION

DIMENSIONS WITHOUT TOLERANCES
ARE FOR REVERENCE ONLY.

DRAWING NUMBER
J-E5-18