



PROPRIETARY ITEM - EXCEPT FOR USES EXPRESSLY GRANTED IN WRITING INFORMATION DISCLOSED HEREON IS CONFIDENTIAL AND ALL RIGHTS PATENT AND OTHERWISE ARE RESERVED BY SOUTHCO, INC.

### AMC MODULE HANDLE AND BLUE LED LIGHT PIPE

DATE	DRAWN	CHKD	SCALE
09NOV2006	MER		1:1

DRAWING NUMBER
J-P7-M-81

REV	DATE	DRAWN/CHKD	DESCRIPTION	HANDLE ASSEMBLY				LIGHT PIPE
A	16FEB2007	RES/AJH	PRN: P2007-0273	PART NUMBER	MODULE SIZE	DIM. A	HANDLE COLOR	PART NUMBER
B	10OCT2008	RES/	PRN: P2008-1109	P7-M-811-000	COMPACT 3HP	12.5	BLACK	P7-10-812
C	01SEP2009	RES/	PRN: P2009-1031	P7-M-812-000	MID SIZE 4HP	17.55	BLACK	
D	10AUG2010	RES/	PRN: P2010-0353	P7-M-813-000	FULL SIZE 6HP	27.55	BLACK	
E	21JUN2016	CMS/DL	PRN: P2016-1442	P7-M-811-XXX	COMPACT 3HP	12.5	SEE NOTE B	
				P7-M-812-XXX	MID SIZE 4HP	17.55	SEE NOTE B	
				P7-M-813-XXX	FULL SIZE 6HP	27.55	SEE NOTE B	

**MILLIMETERS**

ALL DIMENSIONS WITHOUT TOLERANCES ARE FOR REFERENCE ONLY.

THIRD ANGLE PROJECTION A4 PAPER SIZE

SHEET 1 OF 3

#### HANDLE ASSEMBLY

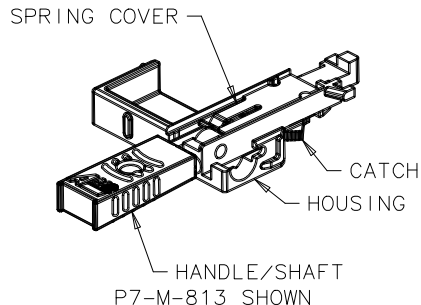

#### NOTES:

- A. HANDLE ASSEMBLY AND LIGHT PIPE ORDERED SEPARATELY. MOUNT HANDLE AND LIGHT PIPE TO PCB USING M2.5 X 6 PAN HEAD SCREW (NOT SUPPLIED).
- B. MATERIAL AND FINISH:
  - HANDLE/SHAFT, AND HOUSING: DIE CAST ZINC, CHROMATE DIP
  - HANDLE BLACK POLYESTER POWDER COATING
  - CATCH: DIE CAST ZINC, NICKEL PLATE
  - SPRING COVER AND COMPRESSION SPRING: TYPE 302 STAINLESS STEEL, NATURAL
  - LIGHT PIPE: POLYCARBONATE, CLEAR, UL94-V0
- \* THIS ASSEMBLY IS RoHS COMPLIANT.
- C. FOR ASSEMBLIES WITH POWDER COATED HANDLE, OTHER THAN BLACK, ADD THREE DIGIT COLOR SUFFIX TO PART NUMBER. COLOR SUFFIX REFERENCE DRAWING J-47-0-3.
- D. HANDLE PORTION MEETS SOUTHCO COSMETIC SPECIFICATION S-121-03 CLASS C (POWDER COATED HANDLE)
- E. MODULE HANDLE MEETS REQUIREMENTS OF PICMG AMC.0 R2.0.
- F. OPERATING FORCE ON HANDLE TO BE 15N MAXIMUM AT ANY POSITION

#### LIGHT PIPE

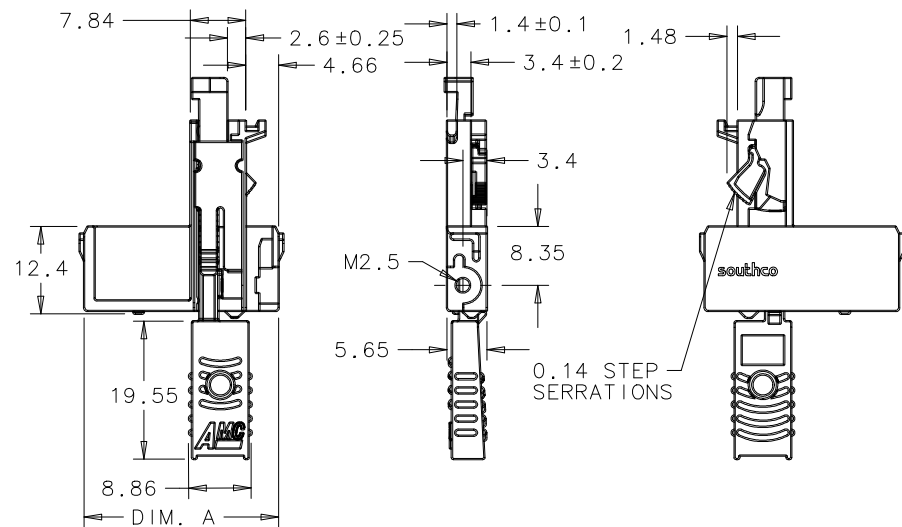
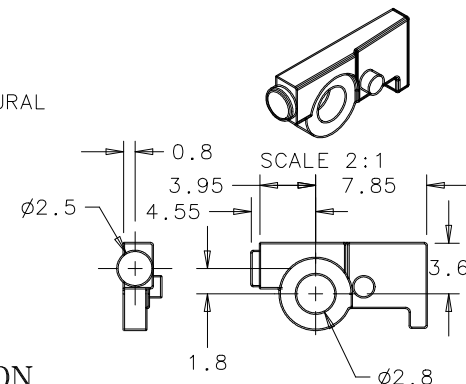

#### HANDLE OPERATION

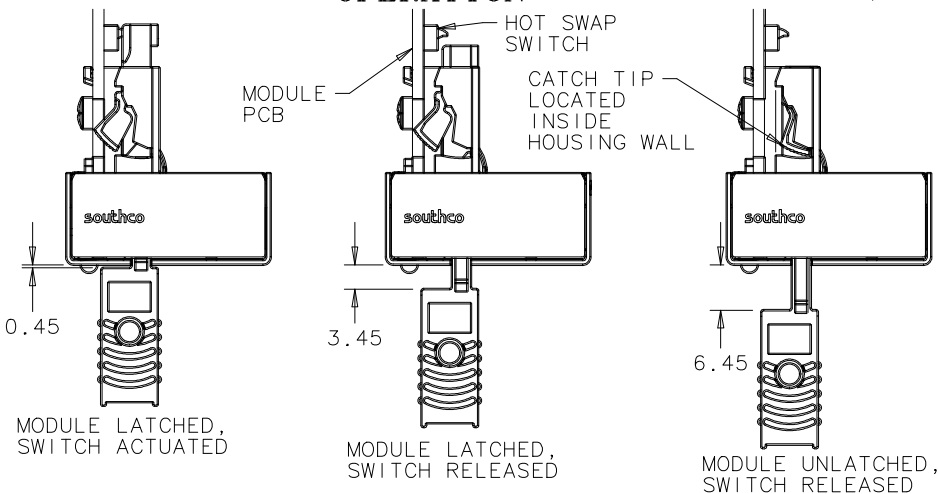

**southco**

PROPRIETARY ITEM - EXCEPT FOR USES EXPRESSLY GRANTED IN WRITING INFORMATION DISCLOSED HEREON IS CONFIDENTIAL AND ALL RIGHTS PATENT AND OTHERWISE ARE RESERVED BY SOUTHCO, INC.

AMC MODULE HANDLE  
AND BLUE LED LIGHT PIPE

DATE	DRAWN	CHKD	SCALE	DRAWING NUMBER
09NOV2006	MER		1:1	J-P7-M-81

REV	DATE	DRAWN/CHKD	DESCRIPTION	HANDLE ASSEMBLY				LIGHT PIPE
A	16FEB2007	RES/AJH	PRN: P2007-0273	PART NUMBER	MODULE SIZE	DIM. A	HANDLE COLOR	PART NUMBER
B	10OCT2008	RES/	PRN: P2008-1109	P7-M-811-000	COMPACT 3HP	12.5	BLACK	P7-10-812
C	01SEP2009	RES/	PRN: P2009-1031	P7-M-812-000	MID SIZE 4HP	17.55	BLACK	
D	10AUG2010	RES/	PRN: P2010-0353	P7-M-813-000	FULL SIZE 6HP	27.55	BLACK	
E	21JUN2016	CMS/DL	PRN: P2016-1442	P7-M-811-XXX	COMPACT 3HP	12.5	SEE NOTE B	
				P7-M-812-XXX	MID SIZE 4HP	17.55	SEE NOTE B	
				P7-M-813-XXX	FULL SIZE 6HP	27.55	SEE NOTE B	

**MILLIMETERS**

ALL DIMENSIONS WITHOUT TOLERANCES ARE FOR REFERENCE ONLY.

THIRD ANGLE PROJECTION  
A4 PAPER SIZE

SHEET 2 OF 3

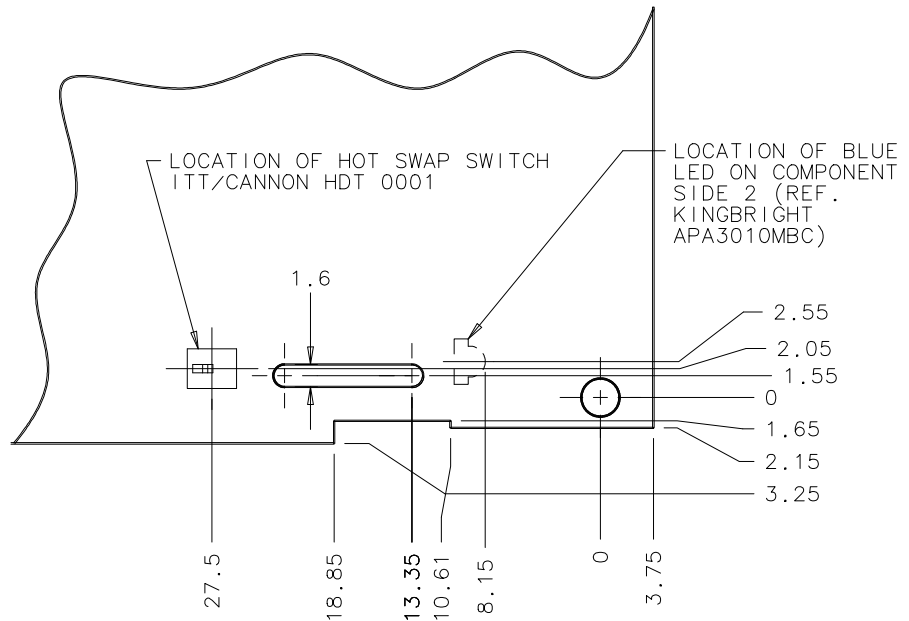

PRINTED CIRCUIT BOARD  
COMPONENT SIDE 1  
SCALE 2:1

ALL PANEL PREPARATION TOLERANCES TO BE ±0.1

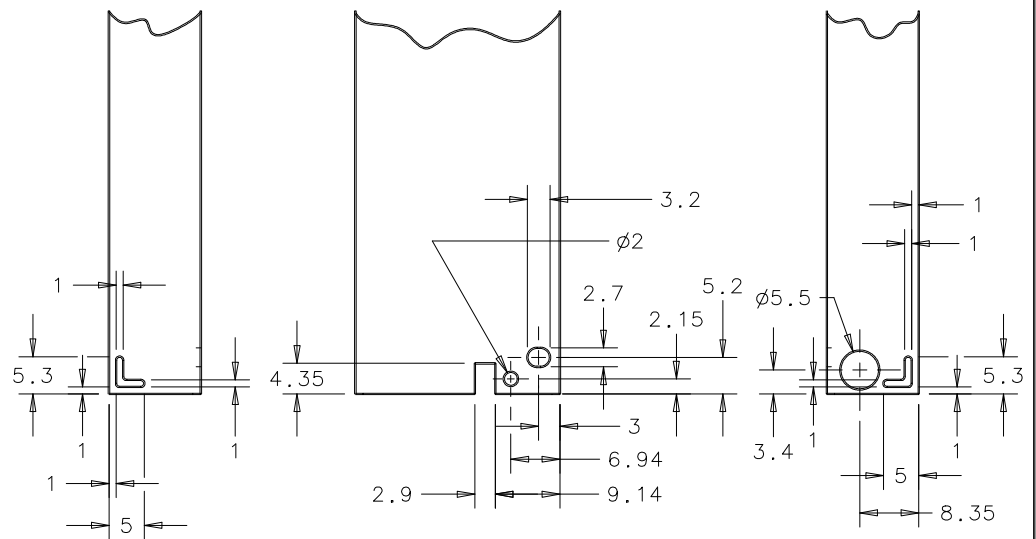
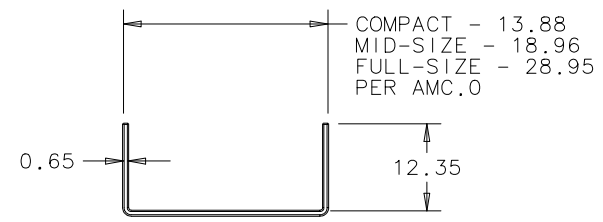

FACEPLATE PREPARATION

**southco**

PROPRIETARY ITEM - EXCEPT FOR USES EXPRESSLY GRANTED IN WRITING INFORMATION DISCLOSED HEREON IS CONFIDENTIAL AND ALL RIGHTS PATENT AND OTHERWISE ARE RESERVED BY SOUTHCO, INC.

AMC MODULE HANDLE AND BLUE LED LIGHT PIPE

DATE	DRAWN	CHKD	SCALE
09NOV2006	MER		1:1

DRAWING NUMBER
J-P7-M-81

REV	DATE	DRAWN/CHKD	DESCRIPTION	HANDLE ASSEMBLY				LIGHT PIPE
A	16FEB2007	RES/AJH	PRN: P2007-0273	PART NUMBER	MODULE SIZE	DIM. A	HANDLE COLOR	PART NUMBER
B	10OCT2008	RES/	PRN: P2008-1109	P7-M-811-000	COMPACT 3HP	12.5	BLACK	P7-10-812
C	01SEP2009	RES/	PRN: P2009-1031	P7-M-812-000	MID SIZE 4HP	17.55	BLACK	
D	10AUG2010	RES/	PRN: P2010-0353	P7-M-813-000	FULL SIZE 6HP	27.55	BLACK	
E	21JUN2016	CMS/DL	PRN: P2016-1442	P7-M-811-XXX	COMPACT 3HP	12.5	SEE NOTE B	
				P7-M-812-XXX	MID SIZE 4HP	17.55	SEE NOTE B	
				P7-M-813-XXX	FULL SIZE 6HP	27.55	SEE NOTE B	

**MILLIMETERS**

ALL DIMENSIONS WITHOUT TOLERANCES ARE FOR REFERENCE ONLY.

THIRD ANGLE PROJECTION A4 PAPER SIZE

SHEET 3 OF 3

**FACE PLATE ASSEMBLY**

REFERENCE DRAWING J-P7-L-81 FOR LIGHT PIPE BRACKET ASSEMBLY DETAILS

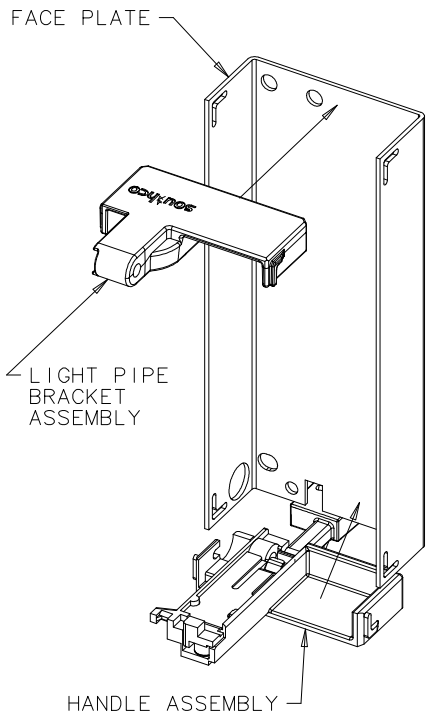

1. SNAP HANDLE ASSEMBLY AND LIGHT PIPE BRACKET ASSEMBLY INTO FACE PLATE.

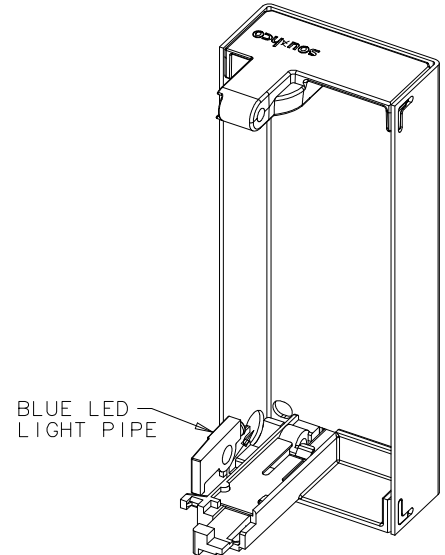

2. POSITION BLUE LED LIGHT PIPE INTO HANDLE ASSEMBLY AND FACE PLATE. LIGHT PIPE SHOULD BE POSITIONED AGAINST OUTSIDE WALL OF HANDLE ASSEMBLY.

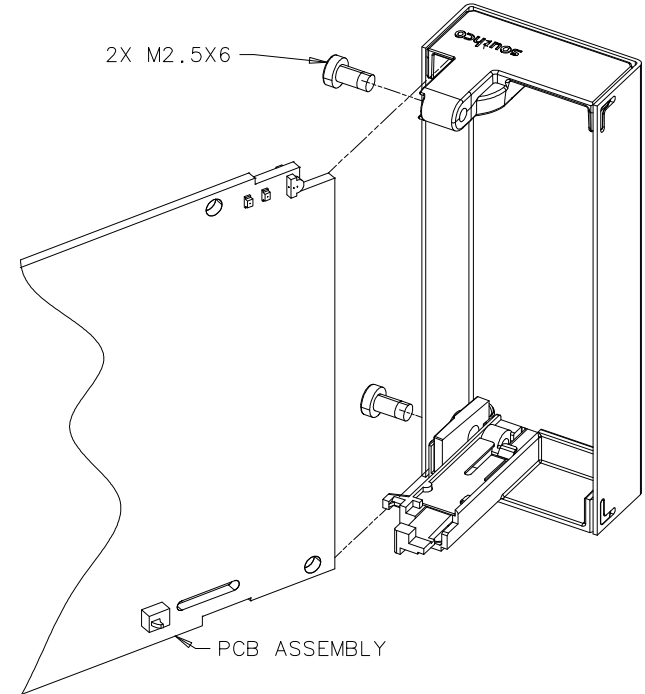

3. SLIDE PCB IN PLACE AND SECURE WITH SCREWS. BLUE LED LIGHT PIPE IS LOCATED ON COMPONENT SIDE 2 OF THE PCB.