

MATERIAL AND FINISH:

DRAWER CUP: ABS, SEE CHART FOR FINISH
 HANDLE: PC/ABS, SEE CHART FOR FINISH
 LATCH HOUSING: NYLON, BLACK
 KEEPER BODY AND ROCKER ARM: GLASS FILLED NYLON, BLACK
 LATCHING PIN: DIE CAST ZINC, CHROME PLATED
 SPRINGS: 302 STAINLESS STEEL, PASSIVATED
 MOUNTING SCREWS: STAINLESS STEEL, BLACK OXIDE
 MAGNETS: NEODYMIUM IRON BORON, NICKEL PLATED

southco

PROPRIETARY ITEM - EXCEPT FOR USES EXPRESSLY GRANTED IN WRITING, INFORMATION DISCLOSED HEREON IS CONFIDENTIAL AND ALL RIGHTS, PATENT AND OTHERWISE ARE RESERVED BY SOUTHCO, INC.

POLAR LATCH ASSEMBLY

DATE	DRAWN	CHKD	SCALE	DRAWING NUMBER
09APR2008	RLR	JWJ	1:1	J-MP-04-33

REV	DATE	DRAWN/CHKD	DESCRIPTION	PART NUMBER	FINISH
A	19SEP2008	JWJ/RLR	PRN: P2008-1034	MP-04-33-55	BLACK
B	27OCT2008	JWJ/RLR	PRN: P2008-1183	MP-04-33-11	POLISHED CHROME
				MP-04-33-44	DIAMOND BRASS
				MP-04-33-22	SATIN CHROME

ALL DIMENSIONS WITHOUT TOLERANCES ARE FOR REFERENCE ONLY.

THIRD ANGLE PROJECTION
 A3 PAPER SIZE

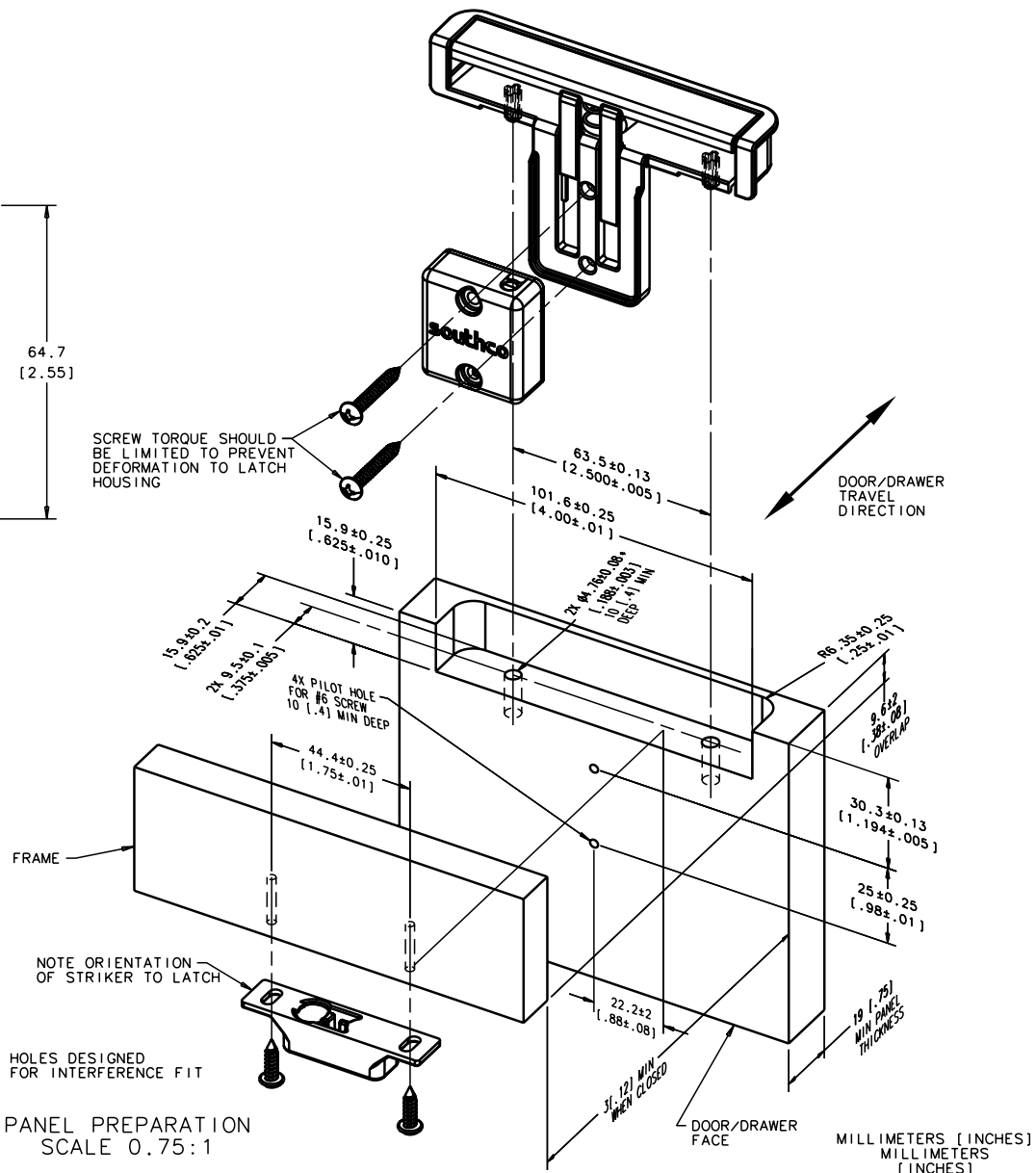
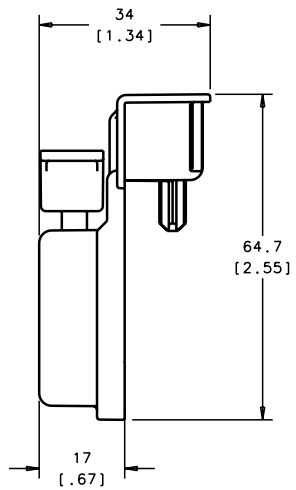
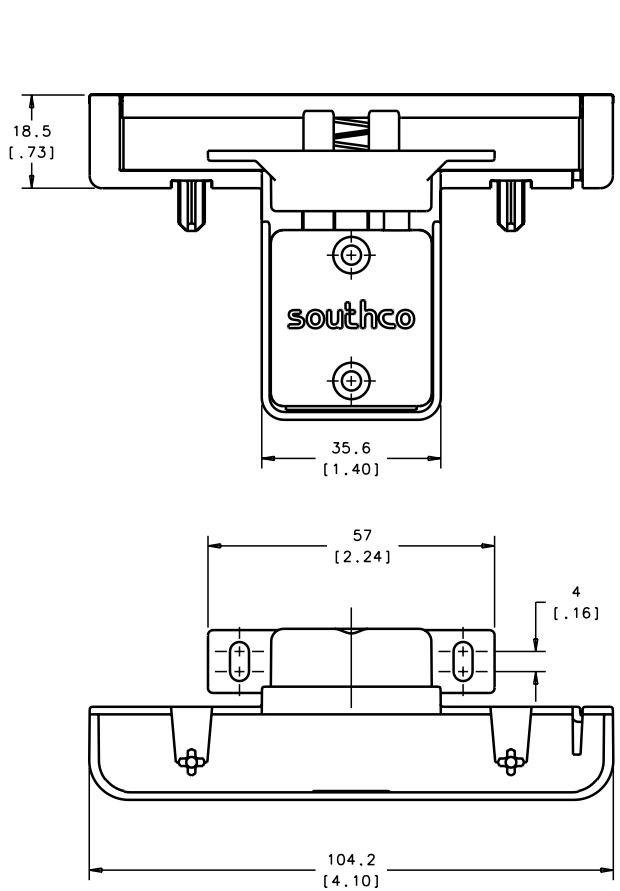

* HOLES DESIGNED FOR INTERFERENCE FIT

PANEL PREPARATION
 SCALE 0.75:1

MILLIMETERS [INCHES]
 MILLIMETERS [INCHES]