

REVISION HISTORY			
REV	DATE	BY	DESCRIPTION
C	04DEC2013	ACH/CMS	PRN: P2013-2411

MATERIAL AND FINISH

- ALL VERSIONS
- HANDLES AND PRIVACY KNOB; POM
 - SCREWS AND WASHERS, 316 STAINLESS STEEL
 - SPRINGS; 304 STAINLESS STEEL
 - STUD; BRASS, NICKEL PLATED
 - EGRESS BUSHING; BRASS NICKEL PLATED
 - MATCHBOW HOUSING AND PLUNGER; ALUMINUM, NATURAL ANODIZED
 - MATCHBOW HOOKS AND STRIKER; BRASS, NICKEL PLATED
 - FOREND; BRASS, NICKEL PLATED
- MM-01-10C-10 & MM-01-10C-40
- ESCUTCHEONS; BRASS, SEE TABLE FOR FINISH
- MM-01-10C-50 & MM-01-10C-60
- ESCUTCHEONS; ALUMINUM, SEE TABLE FOR FINISH

NOTES

- DOOR THICKNESS RANGE "C" ; 20.5 - 38mm [13/16" - 1-1/2"]
- BACKSEAT (A)
 - MIN 21mm [53/64"]
 - MAX 38.5mm [1-33/64"]

PART NUMBER SYSTEM

MM-01-10C-YY

DOOR THICKNESS
MATERIAL &
FINISH

HANDLES AND ESCUTCHEON FINISH	
SUFFIX (-YY)	FINISH
-10	BRIGHT CHROME
-20	SATIN CHROME
-40	DIAMOND BRASS
-50	BLACK POWDER COAT
-60	NATURAL ANODIZED ALUM

DOOR THICKNESS "C"	
PART NUMBER	THICKNESS RANGE
MM-01-100-YY	20.5 - 23mm (13/16 - 29/32")
MM-01-101-YY	22.5 - 27mm (7/8 - 1 1/16")
MM-01-102-YY	27 - 34.5mm (1 1/16 - 1 3/8")
MM-01-103-YY	28.5 - 38mm (1 1/8 - 1 1/2")

PROFILE DOOR INSTALLATION

WOOD DOOR INSTALLATION

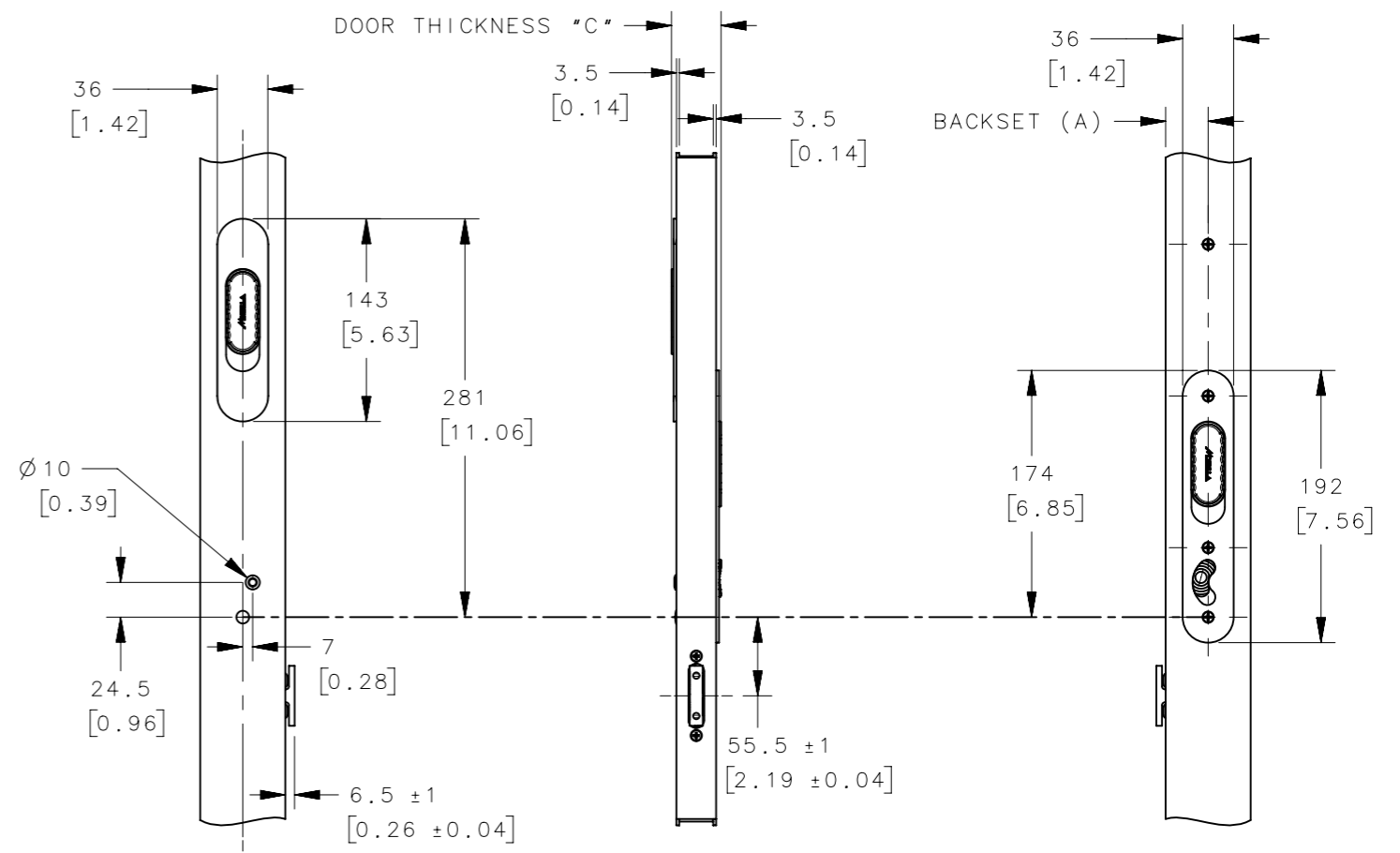
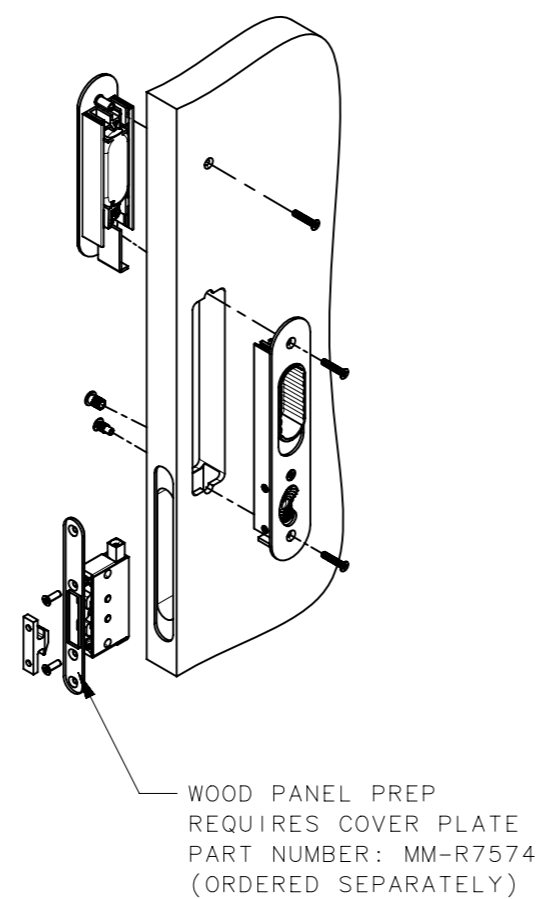
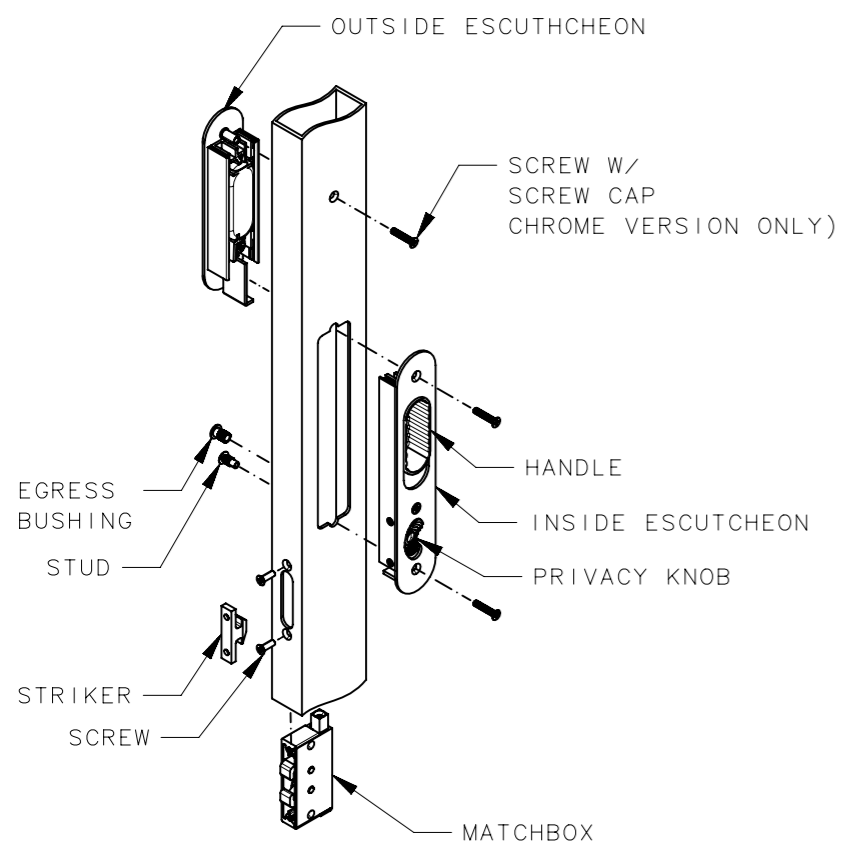

ACCESSORIES	PART NUMBER
MOUNTING TOOL STRIKER	MM-90-103-41
TOP STOP	MM-7520
RAMP TOP STOP	MM-90-201-60
HIGH SEAS HANDLE CHROME	MM-7660
HIGH SEAS HANDLE BLACK	MM-7683

THIRD ANGLE PROJECTION	MILLIMETERS [IN]		 CONNECT • CREATE • INNOVATE	
SURFACE AREA VOLUME	ALL DIMENSIONS WITHOUT TOLERANCES ARE FOR REFERENCE ONLY.		DESCRIPTION	
			TALON ASSEMBLY WITHOUT KEY LOCKING PROFILE DOOR STYLE	
PROPRIETARY ITEM	PER ASME Y14.5M-1994	SIZE	SYSTEM	DWG NO.
EXCEPT FOR USES EXPRESSLY GRANTED IN WRITING, INFORMATION DISCLOSED HEREON IS CONFIDENTIAL AND ALL RIGHTS, PATENT AND OTHERWISE, ARE RESERVED BY SOUTHCO, INC.		A3	NX	J-MM-01-10C-YY
		DRAWN BY	DATE	SCALE
		ACH/MJS	05JAN2010	1:5
				SHEET 1 OF 2

REVISION HISTORY			
REV	DATE	BY	DESCRIPTION
C	04DEC2013	ACH/CMS	PRN: P2013-2411

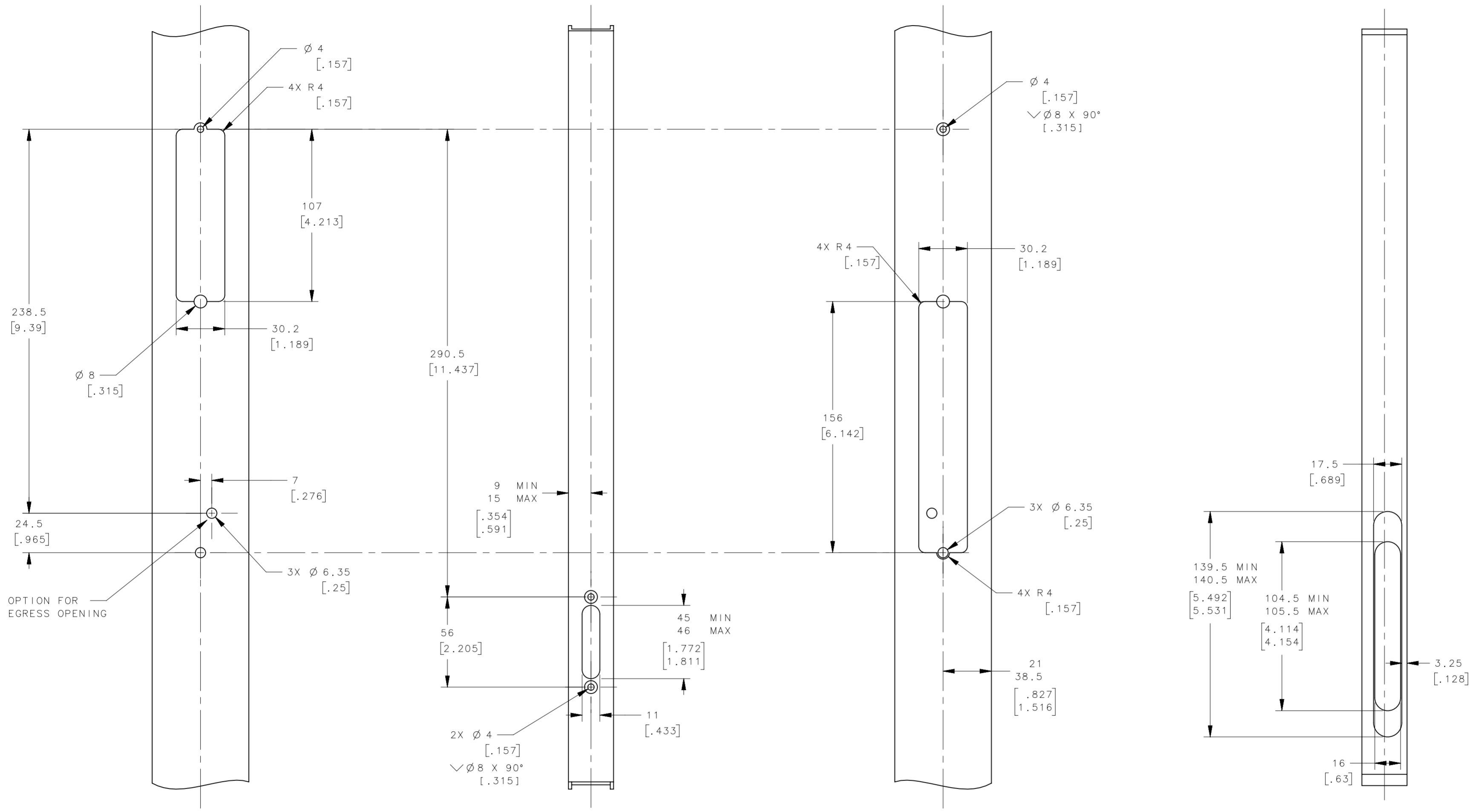

PROFILE DOOR PANEL PREPARATION

WOOD DOOR PANEL PREPARATION

WOOD PANEL PREPARATION REQUIRES COVER PLATE
 PART NUMBER: MM-R7574 (ORDERED SEPARATELY)
 ALL DIMENSIONS THE SAME AS PROFILE DORR PREP
 EXCEPT FOR COVER PLATE DIMENSIONS.

	THIRD ANGLE PROJECTION	southco CONNECT · CREATE · INNOVATE
	MILLIMETERS [IN]	
SURFACE AREA	TOLERANCES UNLESS OTHERWISE NOTED	DESCRIPTION TALON ASSEMBLY WITHOUT KEY LOCKING PROFILE DOOR STYLE
VOLUME	ALL DIMENSIONS WITHOUT TOLERANCES ARE FOR REFERENCE ONLY.	SIZE SYSTEM A2 NX
PROPRIETARY ITEM EXCEPT FOR USES EXPRESSLY GRANTED IN WRITING, INFORMATION DISCLOSED HEREON IS CONFIDENTIAL AND ALL RIGHTS, PATENT AND OTHERWISE, ARE RESERVED BY SOUTHCO, INC.	PER ASME Y14.5M-1994	DWG NO. J-MM-01-10C-YY
		DRAWN BY ACH/MJS
		DATE 05JAN2010
		SCALE 1:2
		SHEET 2 OF 2