

NOTES

- 1. FOR PANEL PREPARATION INSTRUCTIONS SEE DRAWING NUMBER J-MA-BB-C3C-DD-FFF SHEET 2
- 2. DRAWING SHOWS NOVA HANDLES
- 3. FOR STRIKERS SEE: J-MC-90-4XX
- 4. FOR McCOY STAR SLIDER STRIKER; SEE J-MC-90-6XX

PART NUMBER SYSTEM  
MA-BB-C3C-DD-FFF0

PRODUCT  
DIRECTION [A]  
DOOR THICKNESS [C]  
HANDLE  
FINISH

REVISION HISTORY

| REV | DATE      | BY      | DESCRIPTION     |
|-----|-----------|---------|-----------------|
| H   | 18JUL2017 | NDS/YGC | PRN: P2017-1748 |

PRODUCT [BB]

- 02- McCOY STAR
- 07- McCOY STAR WITH DOUBLE SPRING BOLT
- 09- McCOY STAR SLIDER

HANDLE [DD]

- 01-NOVA HANDLE
- 02-PORTOFINO HANDLE

DIRECTION [C1]

- 2-RIGHT OUT [SLIDER R]
- 3-RIGHT IN
- 4-LEFT OUT [SLIDER L]
- 5-LEFT IN

FINISH FOR HANDLE, PRIVACY,

- ACCENTS AND ESCUTCHEON [FF]
- 10-CHROME.
- 14-BRIGHT CHROME WITH DIAMOND BRASS ACCENT.
- 20-SATIN CHROME.
- 40-DIAMOND BRASS.

DOOR THICKNESS [C3]

- 0 - 22-30mm [7/8" - 1 3/16"]
- 1 - 28-37mm [1 1/8" - 1 1/2"]
- 2 - 36.5-45mm [1 7/16" - 1 3/4"]

OTHER HANDLE OPTIONS AVAILABLE REFER TO OLIVARI WEB SITE AND LITERATURE FOR 3 DIGIT HANDLE CODE.

MATERIAL AND FINISH

LATCH MODULE

- LOCK ENGINE: BRASS
- DEAD BOLT: BRASS, NICKEL PLATED
- SPRINGS: 304 STAINLESS STEEL

LOCK MODULE

- LOCK CASE AND COVER PLATE; 316 STAINLESS STEEL
- INTERNAL COMPONENTS: 316 STAINLESS STEEL
- STAR LOCK: BRASS
- SPRINGS: 316 STAINLESS STEEL
- SCREWS: 316 STAINLESS STEEL

FOREND: BRASS, CHROME PLATED

MOUNTING SCREWS M4 POZIDRIVE: 316 STAINLESS STEEL

HANDLES: BRASS, FINISH SEE TABLE

ESCUTCHEONS, ACCENTS AND TURN KNOB: BRASS, SEE TABLE FOR FINISH

SHUTTERS: 316 STAINLESS STEEL, ELECTRO POLISHED

SHUTTER HOUSING: ACETAL, BLACK

DRIVEBAR: BRASS

WASHERS: PA6, WHITE

SET SCREWS 10/32": 316 STAINLESS STEEL

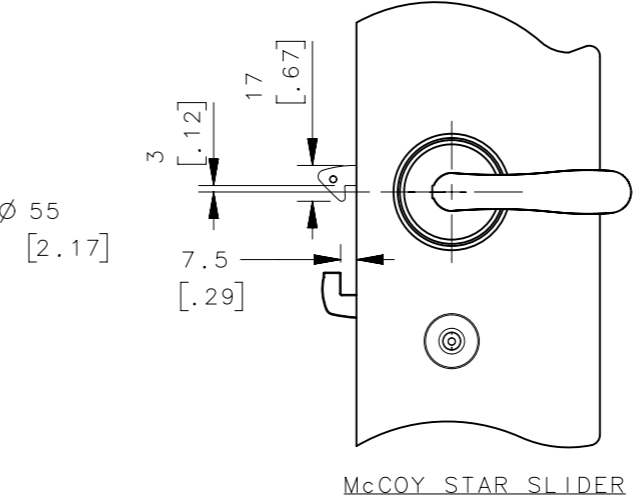
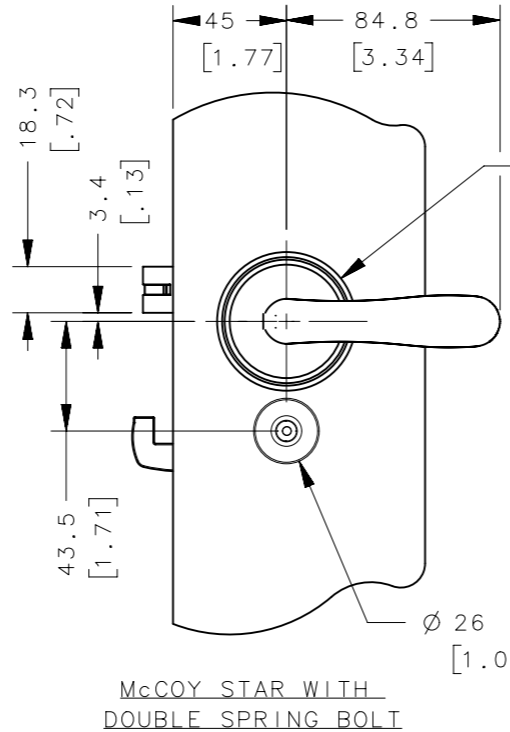
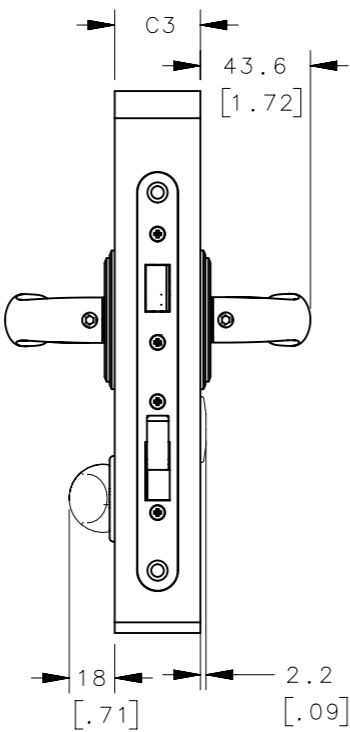
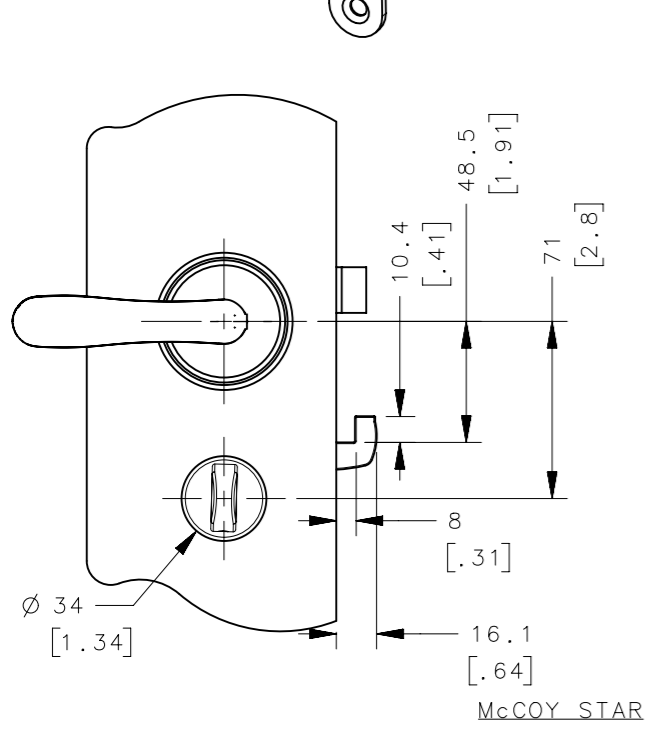
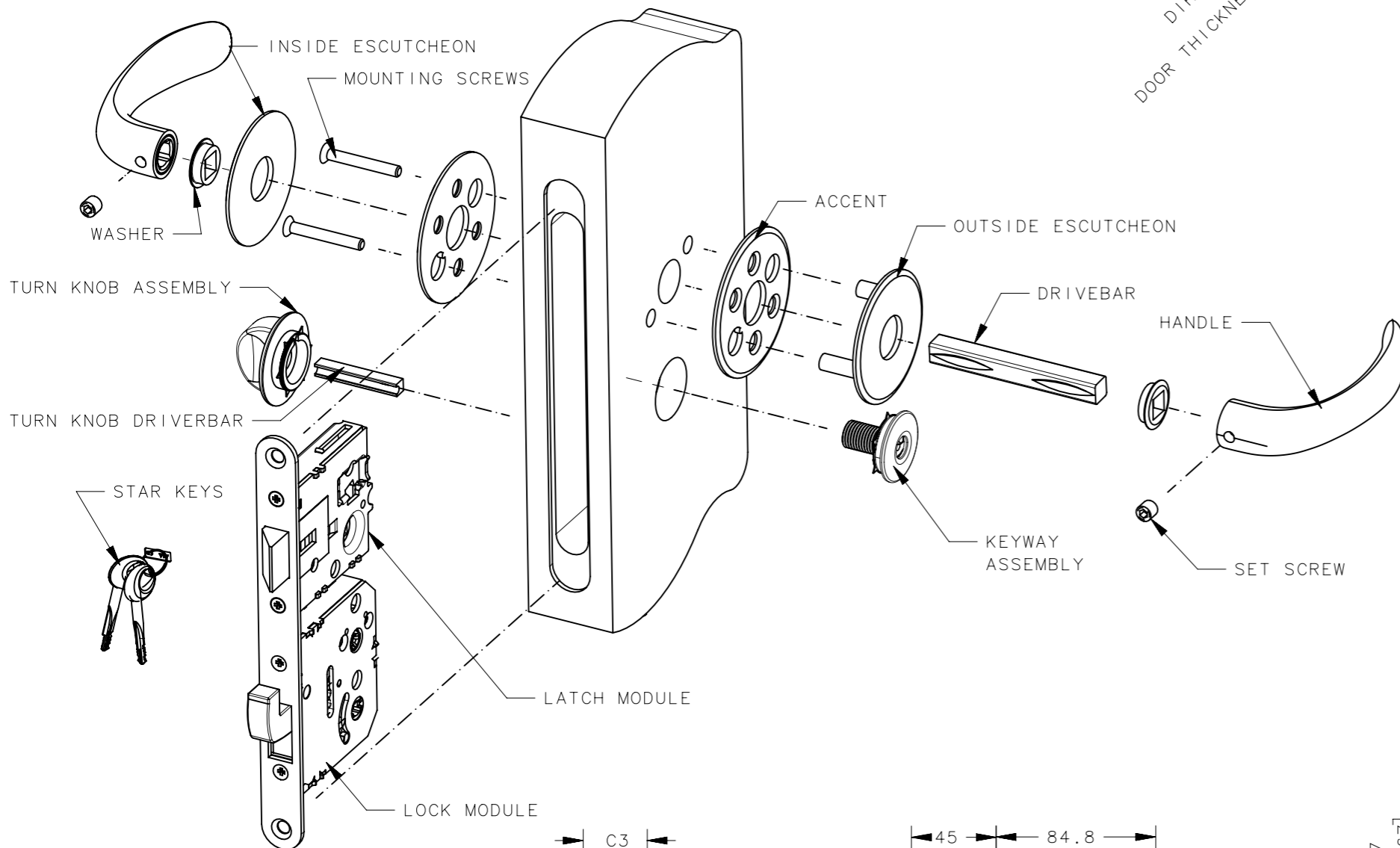

|   |                                   |                     |                               |            |                             |
|---|-----------------------------------|---------------------|-------------------------------|------------|-----------------------------|
| THIRD ANGLE PROJECTION                                    |                                   |                     |                               |            |                             |
|   |                                   |                     |                               |            | CONNECT · CREATE · INNOVATE |
| MILLIMETERS [IN]  | DESCRIPTION<br>McCOY STAR - ROUND |                     |                               |            |                             |
| TOLERANCES UNLESS OTHERWISE NOTED                         | SIZE<br>A3                        | SYSTEM<br>NX        | DWG NO.<br>J-MA-BB-C3C-DD-FFF | SCALE<br>- | SHEET<br>1 OF 4             |
| ALL DIMENSIONS WITHOUT TOLERANCES ARE FOR REFERENCE ONLY. | PER ASME Y14.5M-1994              | DRAWN BY<br>RFA/DTB | DATE<br>14JUNE2012            | SCALE<br>- | SHEET<br>1 OF 4             |

| REVISION HISTORY |           |         |                 |
|------------------|-----------|---------|-----------------|
| REV              | DATE      | BY      | DESCRIPTION     |
| H                | 18JUL2017 | NDS/YGC | PRN: P2017-1748 |

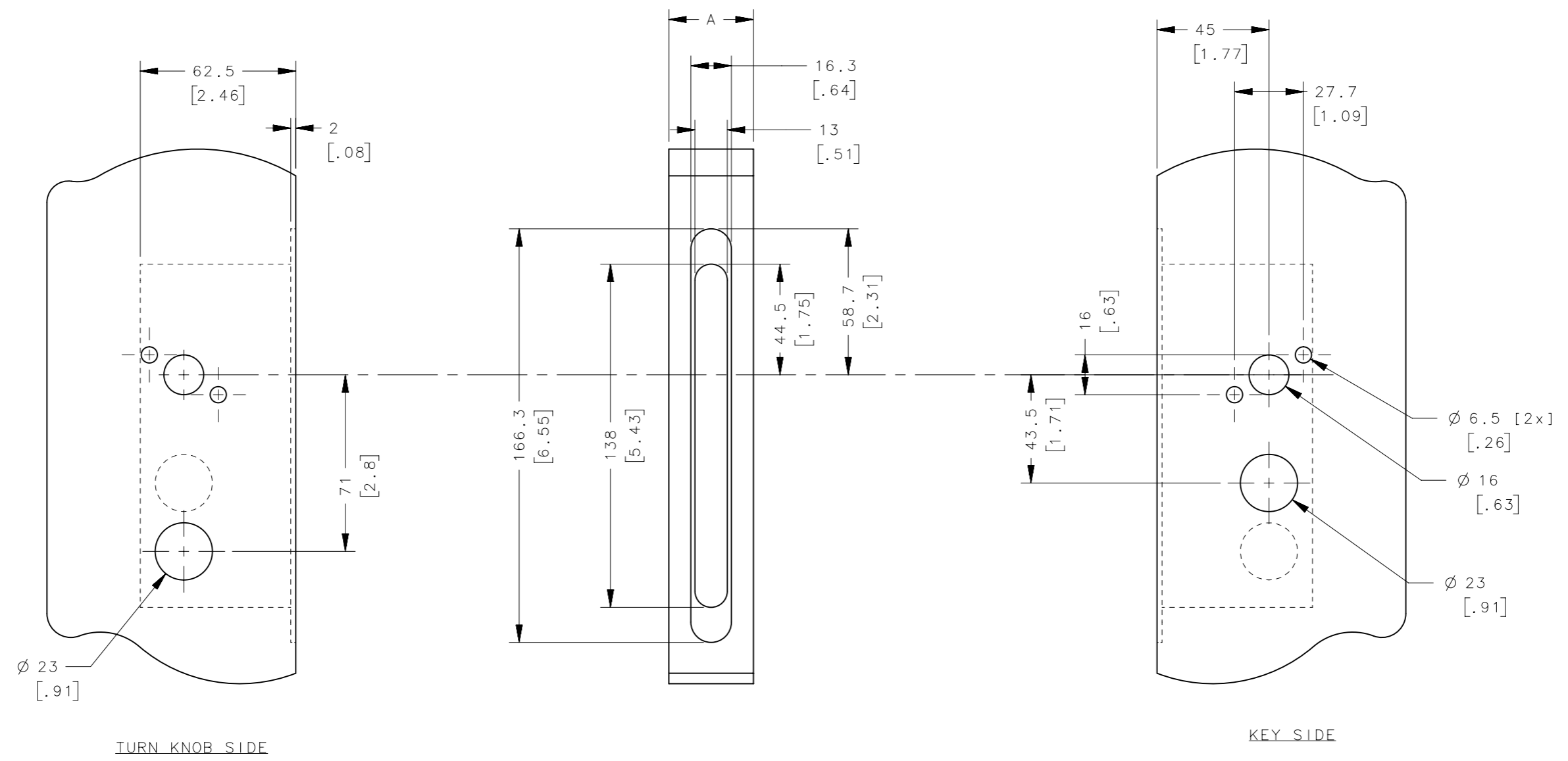

NOTE:  
 PANEL PREPARATION FOR ASSEMBLIES MA-BB-C3C-DD-FF0 AND MA-BB-C3C-DD-FF0  
 1 3 1 3

|  |  |  |                    |
|--|--|--|--------------------|
| THIRD ANGLE PROJECTION   |  | <br>CONNECT • CREATE • INNOVATE                    |                    |
| MILLIMETERS [IN]   |  |  |                    |
| TOLERANCES UNLESS OTHERWISE NOTED  |  | DESCRIPTION<br>McCOY STAR -ROUND-PANEL PREPARATION |                    |
| ALL DIMENSIONS WITHOUT TOLERANCES ARE FOR REFERENCE ONLY.  |  | SIZE<br>A3   | SYSTEM<br>NX       |
| PROPRIETARY ITEM   |  | DWG NO.<br>J-MA-BB-C3C-DD-FFF                      |                    |
| EXCEPT FOR USES EXPRESSLY GRANTED IN WRITING, INFORMATION DISCLOSED HEREON IS CONFIDENTIAL AND ALL RIGHTS, PATENT AND OTHERWISE, ARE RESERVED BY SOUTHCO, INC. |  | DRAWN BY<br>RFA/DTB                                | DATE<br>27JUNE2012 |
| PER ASME Y14.5M-1994   |  | SCALE<br>-   | SHEET<br>2 OF 4    |

NOTES

- FOR PANEL PREPERATION INSTRUCTIONS SEE DRAWING NUMBER J-MA-BB-C3C-DD-FFF SHEET 4
- FOR STRIKERS SEE: J-MC-90-4XX
- FOR McCOY STAR SLIDER STRIKER SEE: J-MC-90-6XX

PART NUMBER SYSTEM  
MA-BB-C3C-DD-FF1

PRODUCT  
DIRECTION 1  
DOOR THICKNESS [A] 3  
HANDLE  
FINISH

PRODUCT [BB]

- 02 - McCOY STAR
- 07 - McCOY STAR WITH DOUBLE SPRING BOLT
- 09 - McCOY STAR SLIDER

DIRECTION [C1]

- 2 - RIGHT OUT [SLIDER R]
- 3 - RIGHT IN
- 4 - LEFT OUT [SLIDER L]
- 5 - LEFT IN

HANDLE [DD]

42-NORDIC HANDLE

MATERIAL FINISH

LATCH MODULE

- LOCK ENGINE; BRASS
- DEAD BOLT; BRASS NICKEL PLATED
- DEAD BOLT McCOY STAR SLIDER: 2348 STAINLESS STEEL
- SPRINGS; 304 STAINLESS STEEL

LOCK MODULE

- LOCK CASE AND COVER PLATE; 316 STAINLESS STEEL
- INTERNAL COMPONENTS; 316 STAINLESS STEEL
- STAR LOCK PLUG; BRASS
- SPRINGS; 316 STAINLESS STEEL
- SCREWS; 316 STAINLESS STEEL

FOREND; BRASS, CHROME PLATED

MOUNTING SCREWS M4 POZIDRIVE; 316 STAINLESS STEEL

HANDLES; BRASS, FINISH SEE TABLE

ESCUTCHEONS, ACCENTS AND TURN KNOB; 316 STAINLESS STEEL, SEE TABLE FOR FINISH

DRIVEBAR; BRASS

WASHERS; PA6 WHITE

SET SCREWS 10/32; 316 STAINLESS STEEL

DOOR THICKNESS [C3]

- 0 - 22-30mm [7/8" - 1 3/16"]
- 1 - 28-37mm [1 1/16" - 1 1/2"]
- 2 - 36.5-45mm [1 7/16" - 1 3/4"]

FINISH FOR HANDLE PRIVACY AND ESCUTCHEONS [FF]

- 10-CHROME
- 20-SATIN CHROME
- 40-DIAMOND BRASS

| REVISION HISTORY |           |         |                 |
|------------------|-----------|---------|-----------------|
| REV              | DATE      | BY      | DESCRIPTION     |
| H                | 18JUL2017 | NDS/YGC | PRN: P2017-1748 |

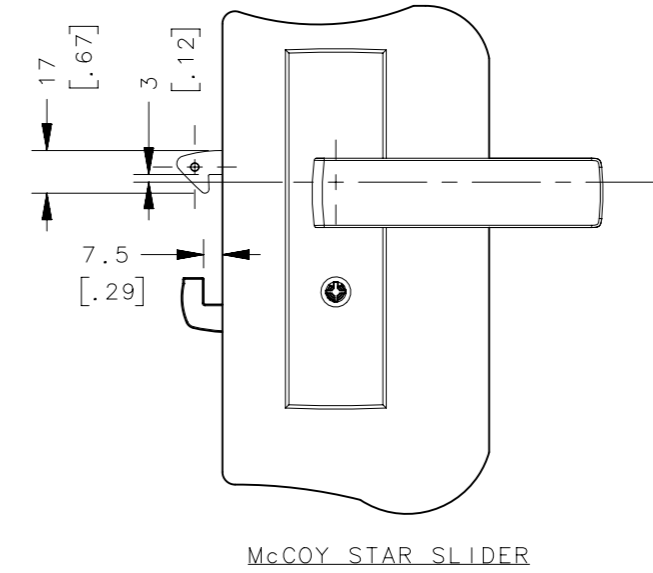
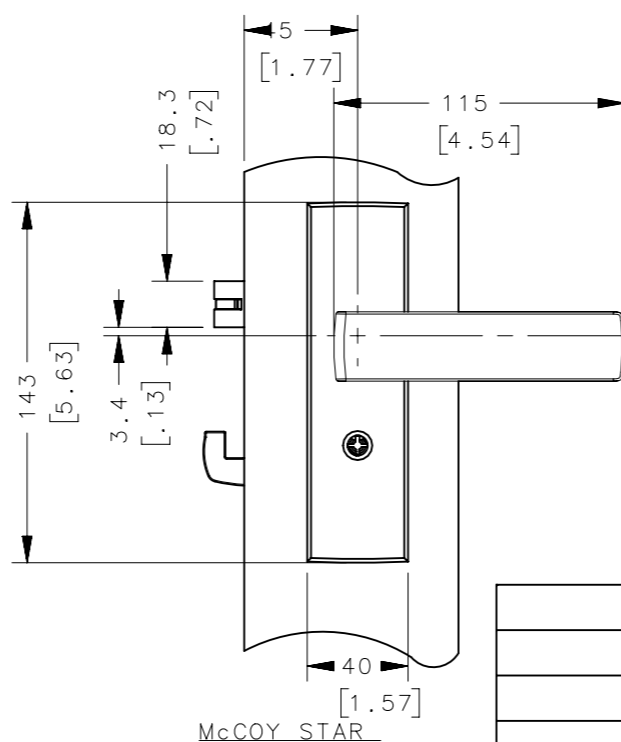
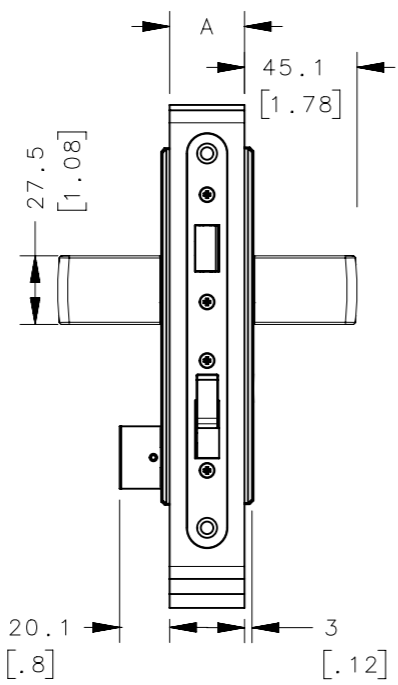
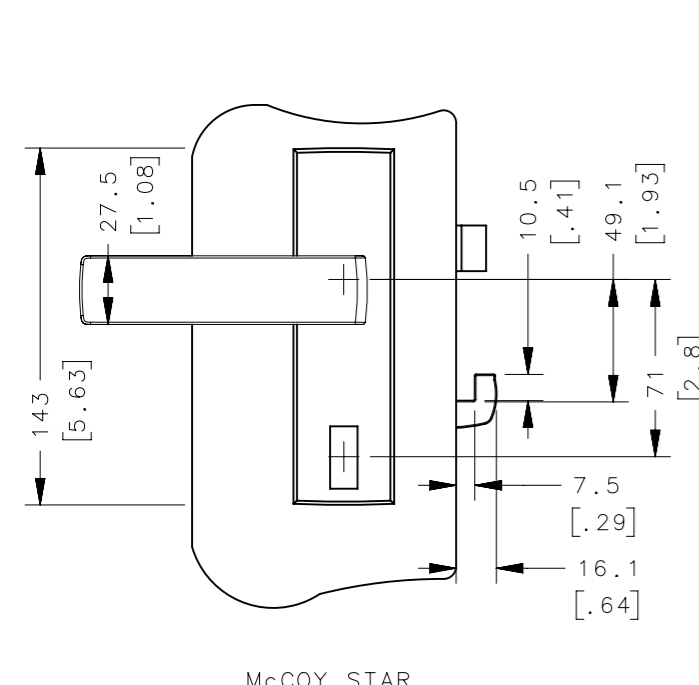
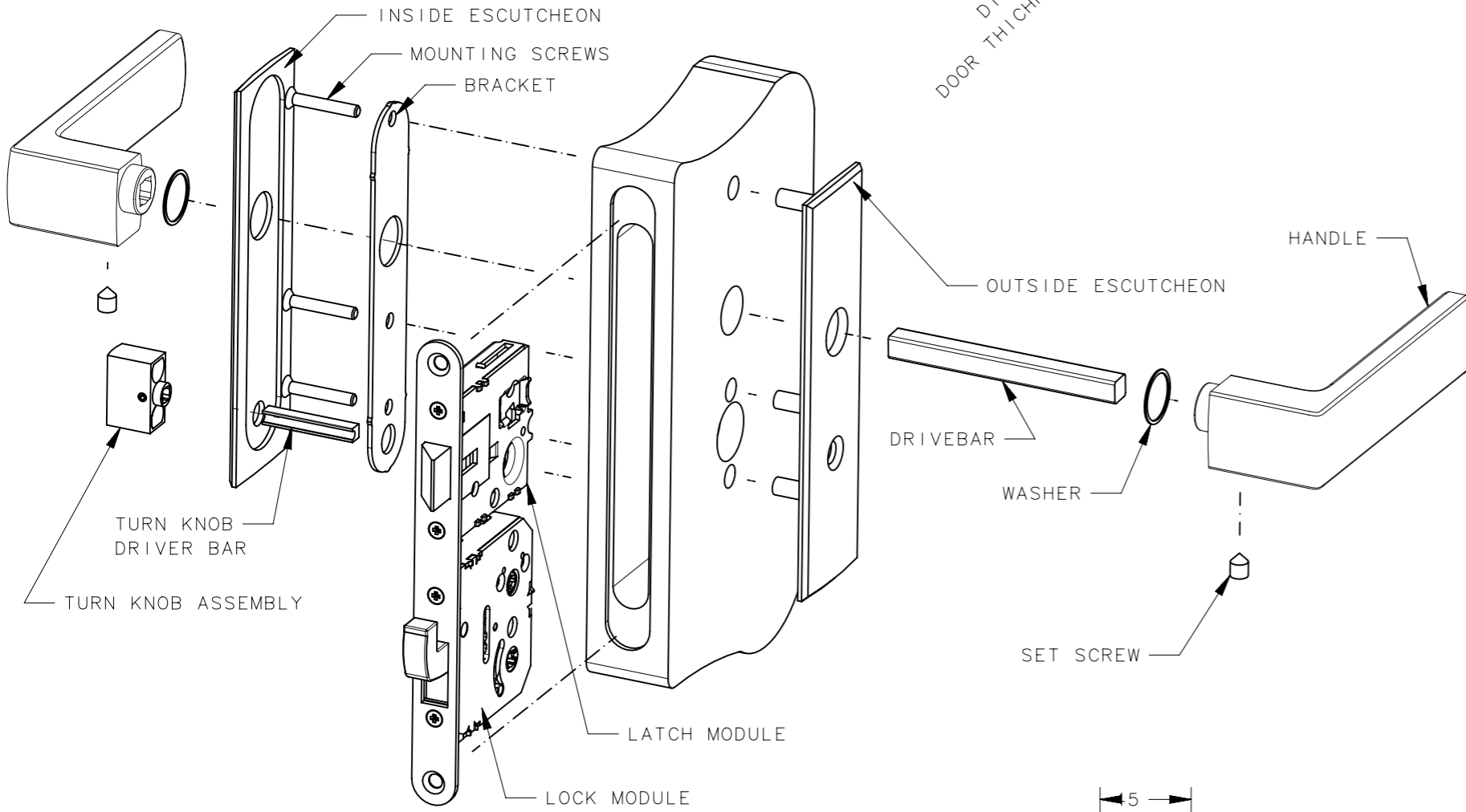

|  |                                   |             |                                 |        |
|--|-----------------------------------|-------------|---------------------------------|--------|
| THIRD ANGLE PROJECTION   | MILLIMETERS [IN]                  |             | <br>CONNECT • CREATE • INNOVATE |        |
|  | TOLERANCES UNLESS OTHERWISE NOTED |             |                                 |        |
| ALL DIMENSIONS WITHOUT TOLERANCES ARE FOR REFERENCE ONLY.  |                                   | DESCRIPTION | McCoy STAR-SQUARE               |        |
| PROPRIETARY ITEM   | SIZE                              | SYSTEM      | DWG NO.                         |        |
| EXCEPT FOR USES EXPRESSLY GRANTED IN WRITING, INFORMATION DISCLOSED HEREON IS CONFIDENTIAL AND ALL RIGHTS, PATENT AND OTHERWISE, ARE RESERVED BY SOUTHCO, INC. | A3                                | NX          | J-MA-BB-C3C-DD-FFF              |        |
| PER ASME Y14.5M-1994   | DRAWN BY                          | DATE        | SCALE                           | SHEET  |
|  | RFA/DTB                           | 04JULY2012  | -                               | 3 OF 4 |

| REVISION HISTORY |           |         |                 |
|------------------|-----------|---------|-----------------|
| REV              | DATE      | BY      | DESCRIPTION     |
| H                | 18JUL2017 | NDS/YGC | PRN: P2017-1748 |

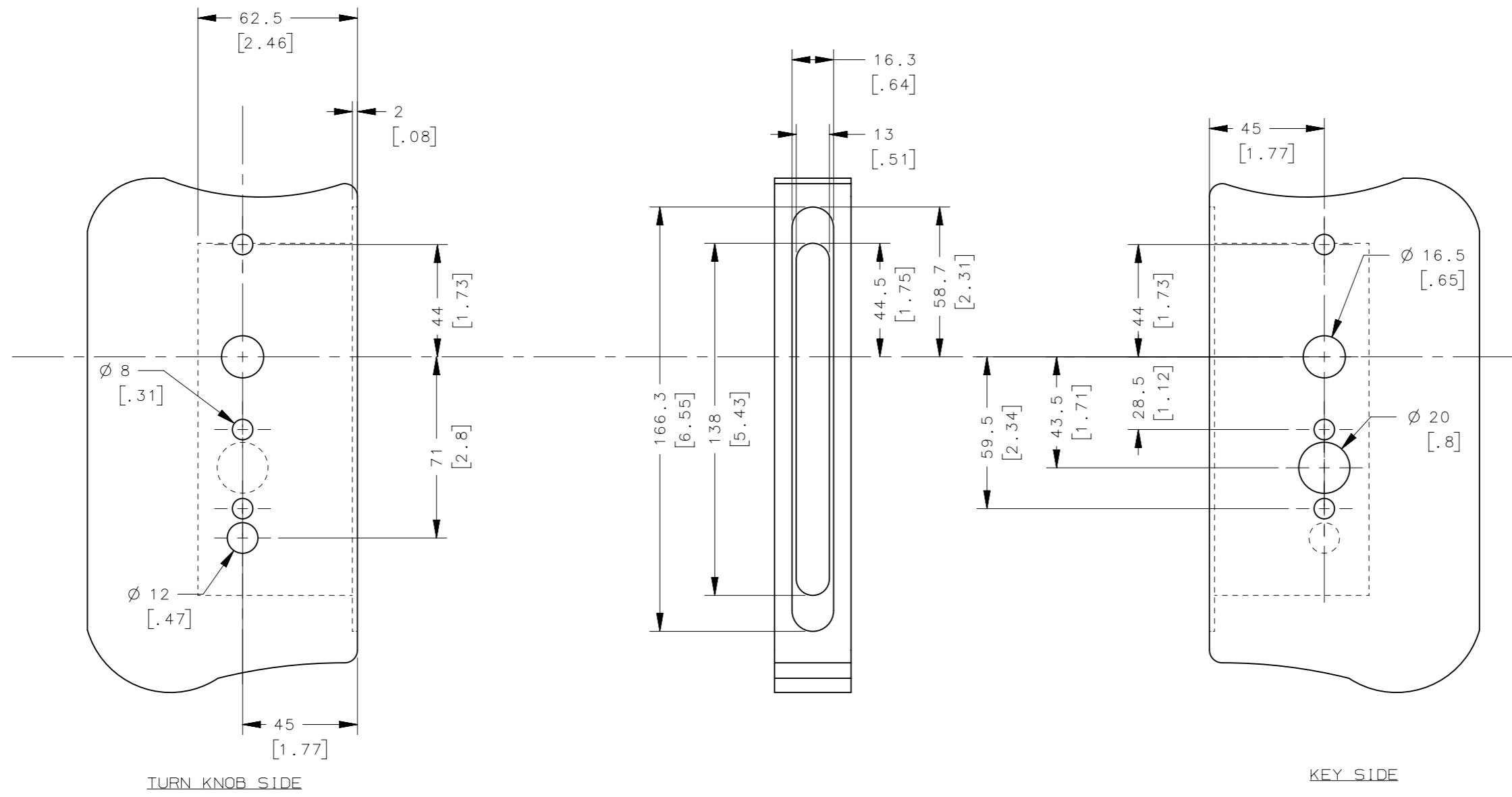

NOTE:  
 PANEL PREPARATION FOR ASSEMBLIES MA-BB-C3C-DD-FF1 AND MA-BB-C3C-DD-FF1  
 1 3 1 3

|  |                      |                                     |                      |
|--|----------------------|-------------------------------------|----------------------|
| THIRD ANGLE PROJECTION   |                      |                                     |                      |
| MILLIMETERS [IN]   |                      |                                     |                      |
| TOLERANCES UNLESS OTHERWISE NOTED  |                      | DESCRIPTION                         |                      |
| ALL DIMENSIONS WITHOUT TOLERANCES ARE FOR REFERENCE ONLY.  |                      | McCOY STAR-SQUARE PANEL PREPARATION |                      |
| PROPRIETARY ITEM   | PER ASME Y14.5M-1994 | SIZE A3                             | SYSTEM NX            |
| EXCEPT FOR USES EXPRESSLY GRANTED IN WRITING, INFORMATION DISCLOSED HEREON IS CONFIDENTIAL AND ALL RIGHTS, PATENT AND OTHERWISE, ARE RESERVED BY SOUTHCO, INC. |                      | DWG NO. J-MA-BB-C3C-DD-FFF          | DATE 04JULY2012      |
|  |                      | DRAWN BY RFA/DTB                    | SCALE - SHEET 4 OF 4 |