

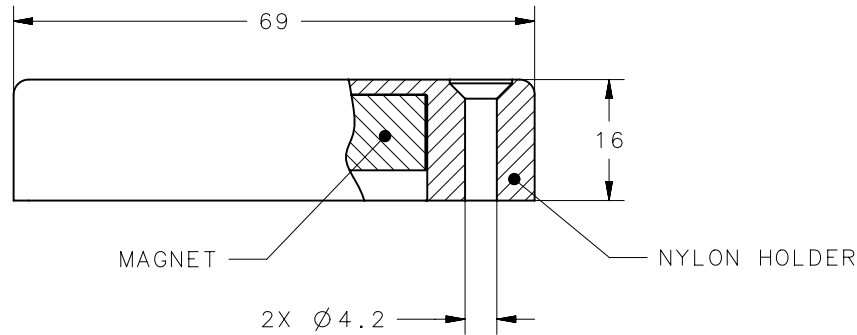

REVISION HISTORY			
REV	DATE	BY	DESCRIPTION
A	11APR2012	DMS/YGC	PRN: P2012-0478

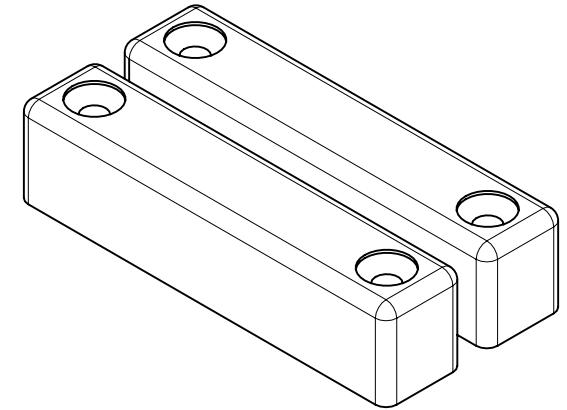
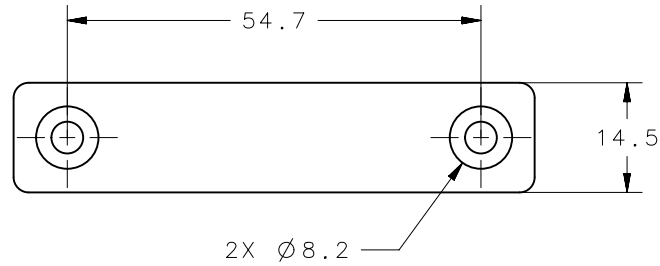
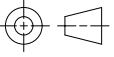

M5-76-100-4	ASSEMBLY, MAGNETIC HATCH HOLDER	NYLON	N/A	BLACK
M5-76-200-4	ASSEMBLY, MAGNETIC HATCH HOLDER	NYLON	N/A	WHITE
PART NUMBER	TYPE OF COMPONENT	MATERIAL	HEAT TREAT	FINISH

	THIRD ANGLE PROJECTION 	 CONNECT • CREATE • INNOVATE		
	MILLIMETERS [IN]			
SURFACE AREA	TOLERANCES UNLESS OTHERWISE NOTED	DESCRIPTION MAGNETIC HATCH HOLDER		
VOLUME	ALL DIMENSIONS WITHOUT TOLERANCES ARE FOR REFERENCE ONLY.	SIZE A4	SYSTEM NX	DWG NO. J-M5-76-X00
PROPRIETARY ITEM EXCEPT FOR USES EXPRESSLY GRANTED IN WRITING, INFORMATION DISCLOSED HEREON IS CONFIDENTIAL AND ALL RIGHTS, PATENT AND OTHERWISE, ARE RESERVED BY SOUTHCO, INC.	PER ASME Y14.5M-1994	DRAWN BY VMV/VGV	DATE 05OCT2007	SCALE 1:1 SHEET 1 OF 1