

REV	DATE	DRAWN/CHKD	DESCRIPTION	ITEM	PART NUMBER	REMARKS	DOOR THICKNESS
D	30NOV2004	AJH/VNI	PRN: P2004-1358	ASSEMBLY	M3-90	WITHOUT LOCK	0 - 5
				ASSEMBLY	M3-91	WITH LOCK	0 - 5
				ASSEMBLY	M3-92	WITHOUT LOCK	5 - 10
				ASSEMBLY	M3-93	WITH LOCK	5 - 10

MILLIMETERS

ALL DIMENSIONS WITHOUT TOLERANCES ARE FOR REFERENCE ONLY.



THIRD ANGLE PROJECTION

A3 PAPER SIZE

INSTALLATION SCHEMATIC

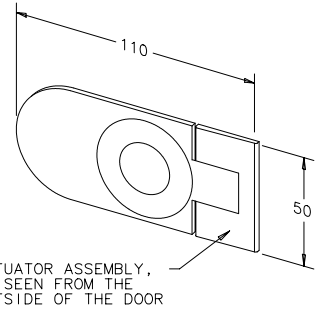
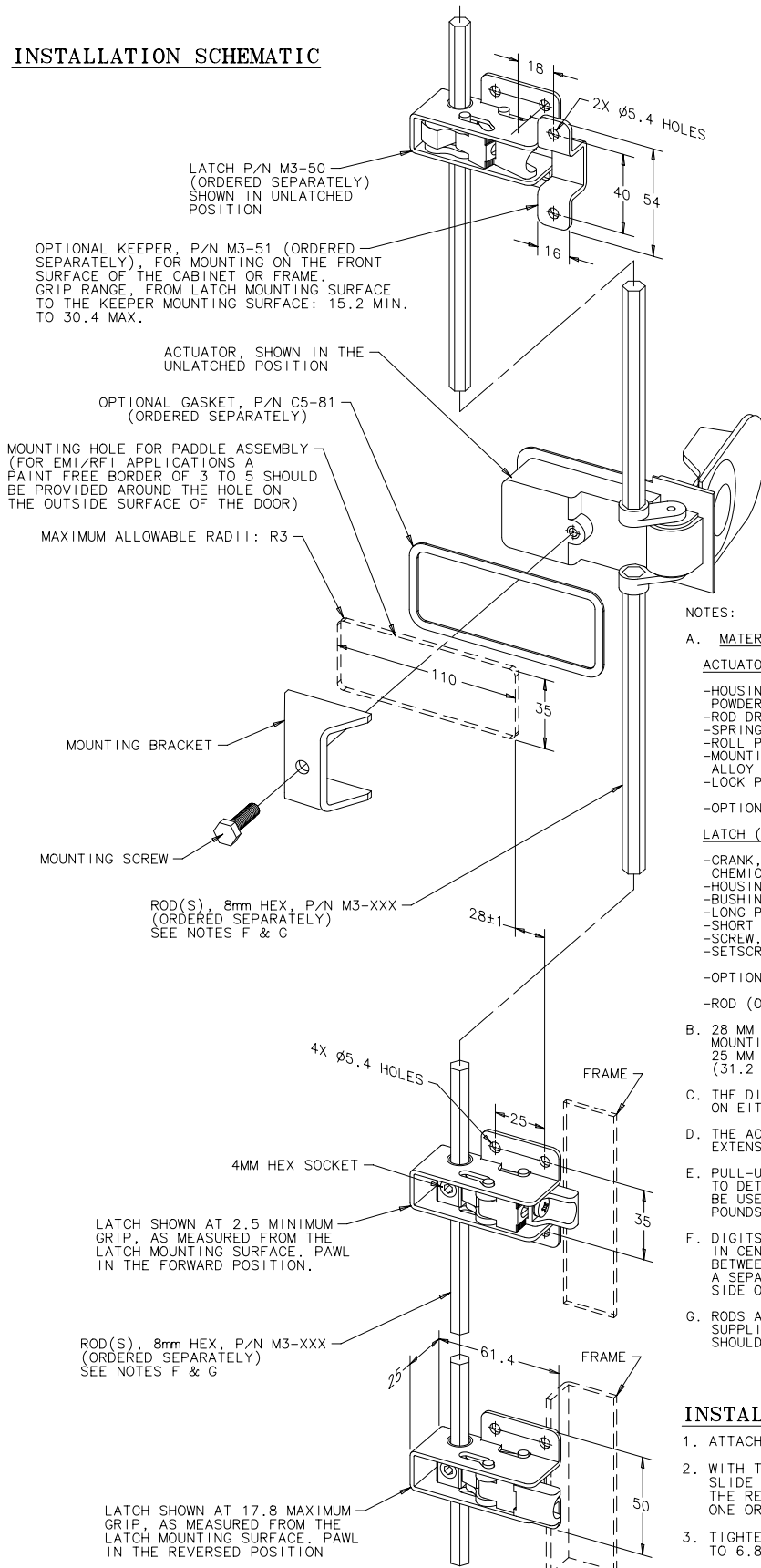

- NOTES:
- A. MATERIAL AND FINISH:
- ACTUATOR:
- HOUSING, HANDLE AND TRIGGER: DIE CAST ZINC, BLACK POWDER COATED
 - ROD DRIVERS: DIE CAST ZINC, CHEMICAL PROTECTIVE FILM
 - SPRING: 302 STAINLESS STEEL, PASSIVATED
 - ROLL PIN: 420 STAINLESS STEEL, PASSIVATED
 - MOUNTING BRACKET AND SOCKET HEAD SCREW: STEEL, ZINC ALLOY PLATED
 - LOCK PLUG: GLASS FILLED ACETAL, BLACK.
- OPTIONAL DUST AND MOISTURE GASKET: NEOPRENE, BLACK
- LATCH (ORDERED SEPARATELY):
- CRANK, PAWL SUPPORTS AND PAWL: DIE CAST ZINC, CHEMICAL PROTECTIVE FILM
 - HOUSING AND LINKS: 1008/1010 STEEL, ZINC PLATED BRIGHT
 - BUSHINGS: STEEL, ZINC PLATED BRIGHT
 - LONG PIN: LOW CARBON STEEL, NICKEL PLATED
 - SHORT PIN: LOW CARBON STEEL, ZINC PLATED
 - SCREW, LOCKWASHER AND NUT: STEEL, ZINC PLATED YELLOW
 - SETScrew: STEEL, ZINC PLATED YELLOW WITH NYLON PATCH.
- OPTIONAL KEEPER: 1008/1010 STEEL, ZINC PLATED YELLOW.
- ROD (ORDERED SEPARATELY): 303 STAINLESS STEEL, NATURAL.
- B. 28 MM INWARD CLEARANCE IS REQUIRED FOR THE ACTUATOR'S MOUNTING BRACKET AND SCREW. 25 MM INWARD CLEARANCE IS REQUIRED FOR THE LATCHES, (31.2 MM WHEN LATCHES ARE ADJUSTED TO MAXIMUM GRIP).
- C. THE DISTANCE FROM THE ACTUATOR TO THE NEAREST LATCH ON EITHER SIDE MUST BE AT LEAST 300mm.
- D. THE ACTION OF THE LATCHES CONSIST OF 11 FORWARD EXTENSION AND 6 PULL-UP.
- E. PULL-UP FORCE PER LATCH SHOULD NOT EXCEED 445 N (100 LBS). TO DETERMINE THE MINIMUM NUMBER OF LATCHES WHICH MUST BE USED, DIVIDE THE TOTAL REQUIRED PULL-UP FORCE IN POUNDS BY 445 N (100 LBS).
- F. DIGITS *XXX* IN ROD PART NUMBER (M3-XXX) DESIGNATES LENGTH IN CENTIMETERS. MINIMUM ROD LENGTH = CENTER-TO-CENTER BETWEEN ACTUATOR AND OUTERMOST LATCH ON EACH SIDE. A SEPARATE ROD IS REQUIRED FOR A SET OF LATCHES ON EACH SIDE OF THE ACTUATOR.
- G. RODS ARE MANUFACTURED TO SPECIAL SPECIFICATIONS. RODS NOT SUPPLIED BY SOUTHCO SHOULD BE STAINLESS STEEL OR STEEL AND SHOULD HAVE NO MORE THAN 1° TWIST IN ANY 90 CENTIMETER LENGTH.

INSTALLATION INSTRUCTIONS:

1. ATTACH THE ACTUATOR (AND LATCHES) TO THE DOOR.
2. WITH THE LATCHES AND THE ACTUATOR IN THE LATCHED POSITION, SLIDE THE ROD THROUGH ALL OF THE ASSEMBLIES. (BECAUSE OF THE RETURN BEND ON THE DOOR, IT MAY BE NECESSARY TO ATTACH ONE OR MORE LATCHES AFTER THE ROD IS INSTALLED).
3. TIGHTEN THE SETSCREWS IN THE LATCHES TO 4.5 N_W (40IN-LBS) TO 6.8 N_W (60IN-LBS) TORQUE.
4. ADJUST THE LATCHES FOR THE PROPER GRIP (PAWL ADJUSTS TO .76 INCREMENTS) AND TIGHTEN THE PAWL SCREWS SECURELY.