

REVISION HISTORY			
REV	DATE	BY	DESCRIPTION
B	08APR2015	DMS/YGC	PRN: P2015-0682

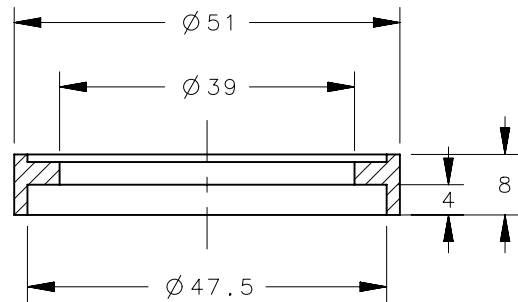
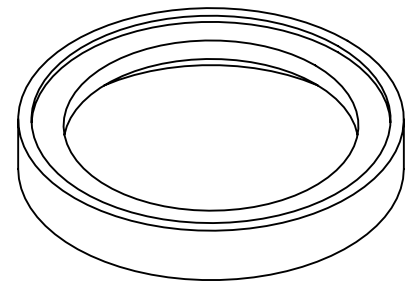
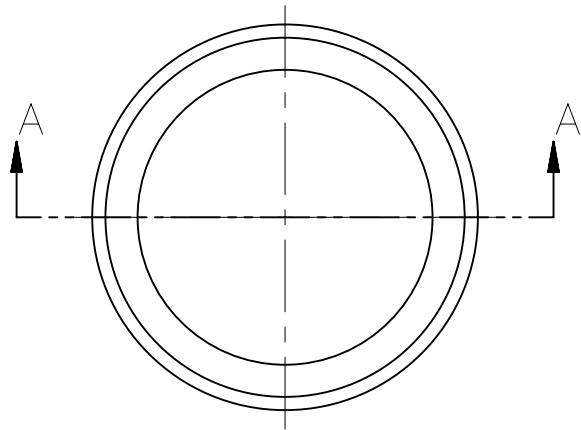

SECTION A-A

M1-510-96-1	SPACER	NYLON	BLACK
PART NUMBER	TYPE OF COMPONENT	MATERIAL	FINISH
	THIRD ANGLE PROJECTION	 CONNECT • CREATE • INNOVATE	
	MILLIMETERS [IN]		
SURFACE AREA	TOLERANCES UNLESS OTHERWISE NOTED	DESCRIPTION	
VOLUME	ALL DIMENSIONS WITHOUT TOLERANCES ARE FOR REFERENCE ONLY.	M1-15 SPACER	
PROPRIETARY ITEM	PER ASME Y14.5M-1994	SIZE A4	SYSTEM NX
EXCEPT FOR USES EXPRESSLY GRANTED IN WRITING, INFORMATION DISCLOSED HEREON IS CONFIDENTIAL AND ALL RIGHTS, PATENT AND OTHERWISE, ARE RESERVED BY SOUTHCO, INC.		DWG NO. J-M1-510-96-1	DATE 05MAR2015
		DRAWN BY DMS/YGC	SCALE 1:1
			SHEET 1 OF 1