

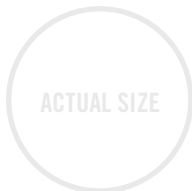

61 Cam Latch

Universal cabinet series · Adjustable grip

Knob Style

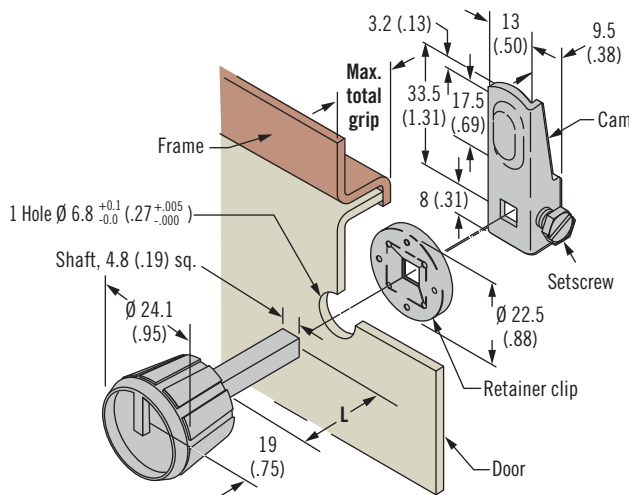

- Single hole installation
- Accommodates wide grip ranges

Material and Finish

Nylon and steel, zinc plated

Performance Details

Maximum static load: 110 N (25 lbf)

Notes

Knob style shown. Additional L-handle and flush slotted styles available

Maximum Total Grip	Shaft Length L	Assembly Part number
12.5 (.50)	25.5 (1.00)	61-10-102-11
25 (1.00)	38 (1.50)	61-10-104-11
44.5 (1.75)	57 (2.25)	61-10-107-11

Other options available. For complete details on variety, part numbers, installation and specification, go to

INFO CLIC www.southco.com/61

92 Cam Latch

T, Compact-T and L-handle · Adjustable grip



Compact T-handle

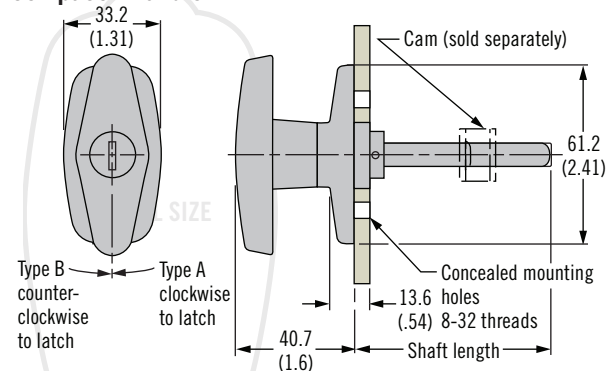

Cam

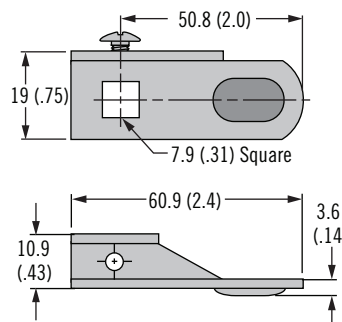

Finish	Shaft Length	Locking Compact-T Part Number	
		Type A	Type B
Black	38.1 (1.5)	92-61-113-50	92-61-213-50
	50.8 (2.0)	92-61-114-50	92-61-214-50
	63.5 (2.5)	92-61-115-50	92-61-215-50

Cam Part Number
92-24-203-12

Compact T-handle style shown. T and L-handle style available. Locking and non-locking.

- Easy cam adjustments

Material and Finish

Zinc alloy, powder coated or chrome plated and steel, zinc plated

Performance Details

Maximum static load: 150 N (34 lbf)

Notes

Black and chrome finish available
For versions with threaded shaft see page 134.

For fixed grip versions see page 124.

Gasket Part Number: 92-70-G (sold separately)

Other options available. For complete details on variety, part numbers, installation and specification, go to

INFO CLIC www.southco.com/92

Southco® Pawl/Cam Action Latches

Universal Cabinet Series

- For lighter-duty applications
- Accommodates wide grip ranges
- Three handle- and headstyle actuators
- Single-hole installation

All latch styles are dimensionally identical to the Knob style except as shown.

Thermoplastic Knob Styles

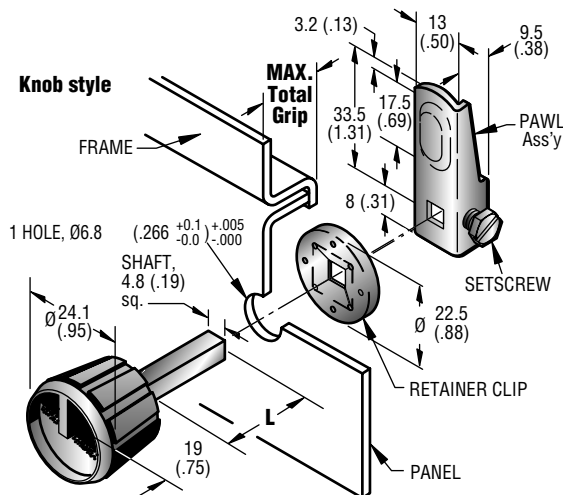

MAX. Total Grip	Shaft Length L	ASSEMBLY PART NUMBERS	
		Knob	
12.5 (.50)	25.5 (1.00)	61-10-102-11 •	
25 (1.00)	38 (1.50)	61-10-104-11 •	
44.5 (1.75)	57 (2.25)	61-10-107-11 •	

Steel L-handle and Slotted Styles

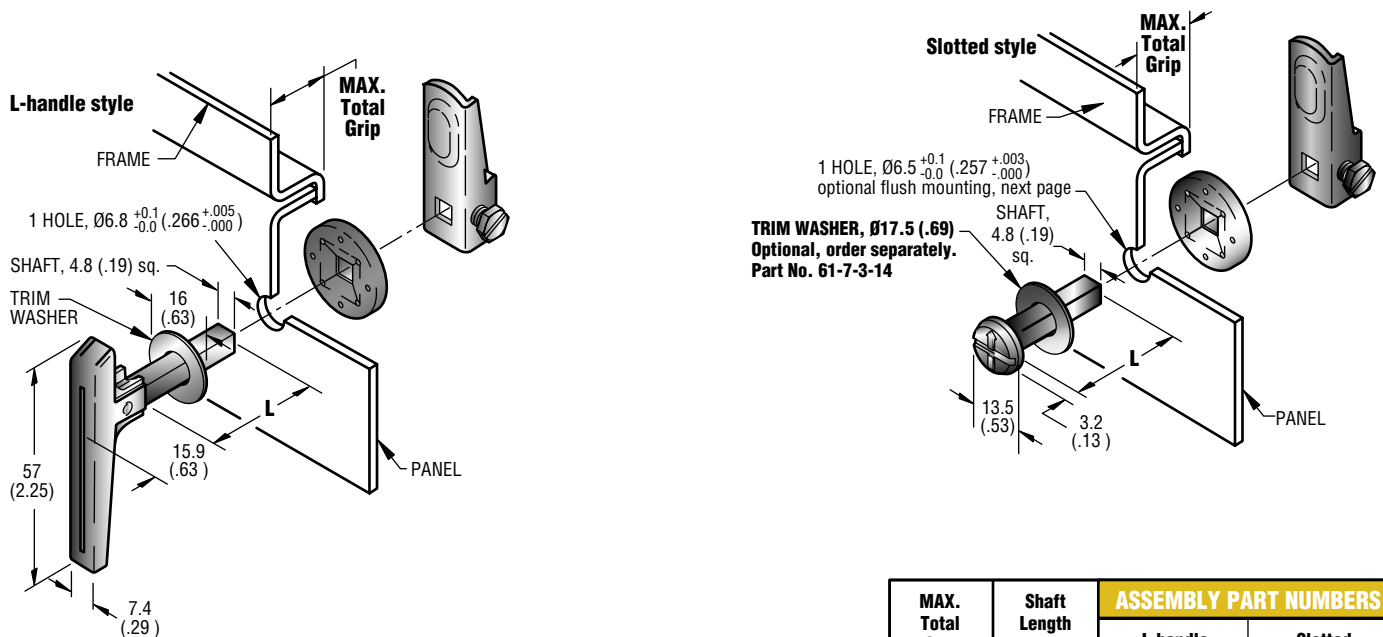

MAX. Total Grip	Shaft Length L	ASSEMBLY PART NUMBERS	
		L-handle	Slotted
44.5 (1.75)	57 (2.25)	61-1-1-0 •	—
19 (.75)	32 (1.25)	—	61-10-4-0 •
25 (1.00)	38 (1.50)	61-1-4-0 •	61-10-1-0 •
12.5 (.50)	25.5 (1.00)	—	61-10-6-0 •
32 (1.25)	44.5 (1.75)	61-1-7-0	61-10-7-0 •
38 (1.50)	51 (2.00)	—	61-10-2-0 •
57 (2.25)	70 (2.75)	—	61-10-3-0 •

Installation

For all styles.

1. Prepare panel.

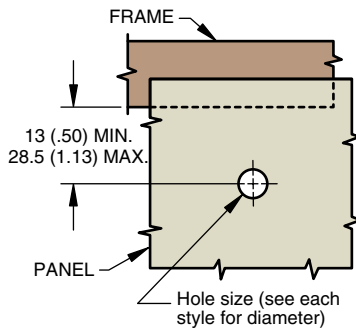

2. Press retainer down shaft until snug against panel using shaped installed tool. *21 (.81) O.D. tubing can be used.*
3. Adjust pawl to proper grip position and tighten setscrew.

Retainer clip Installation Tool

Order separately

PART NUMBER

61-0-12280-11 •

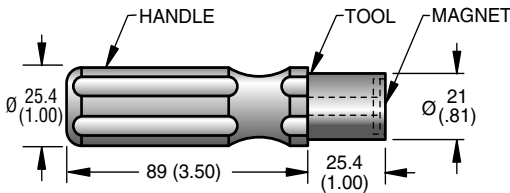

Material and Finish

Steel, zinc plated tool with magnetic insert. Black cellulose acetate handle.

Optional Flush Mounting Cup for slotted style assemblies

(Order separately)

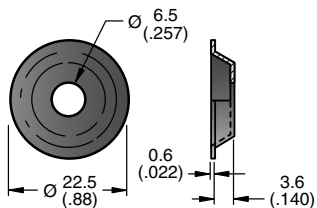

PART NUMBER

61-16-101-14 •

Material and Finish

1010 Steel, bright nickel plated.

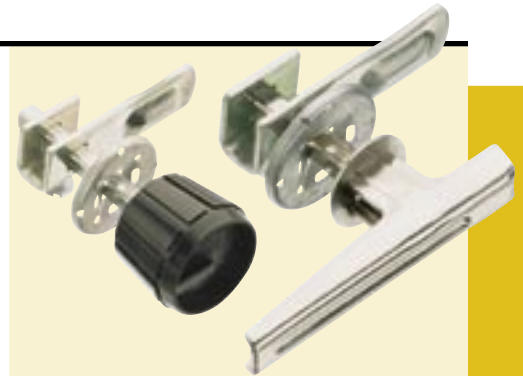
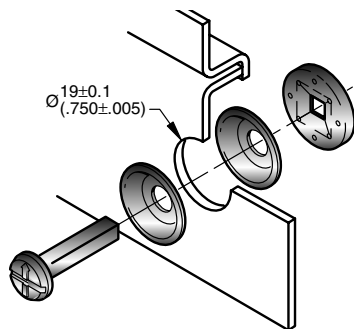
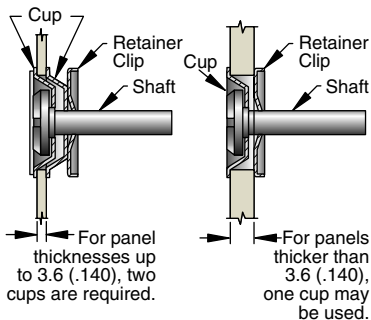

Pawl/Cam Action Latches

Material and Finish

KNOB: Nylon, black.

L-HANDLE: 1010 Steel, bright nickel plated.
SHAFTS and SLOTTED HEAD: 1008 Steel, bright nickel plated. PAWL: 1010 Steel, zinc plate, chromate plus sealer.

TRIM WASHER: Low carbon steel, bright nickel plated.

RETAINER: Spring steel zinc immersion coating.

SETScrew: Hardened steel, zinc plated plus chromate dip, bright.

Product Strength Guidelines

(To assist in your product selection; samples are available for your evaluation.)

Maximum static load - 110 N (25 lbs.)

millimeter (inch)
millimeter (inch)

Dimensions without tolerances are for reference only.