

Stepper motors

with integrated positioning control

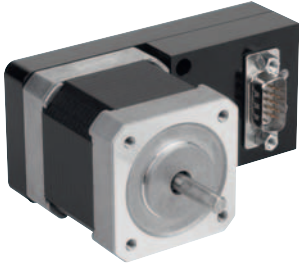

Version:

2-phase high-torque stepper motor in NEMA 17, NEMA 23 and NEMA 34 sizes with flat-milled shaft (D-shaft). $1.8\frac{\square}{\square}^{\circ}$ increment angle (full increment) with integrated positioning control.

Sample order:

nlm 85000-10-230200

Note:

Stepper motor with integrated positioning control. It forms a convenient unit consisting of stepper motor and intelligent controller. Reference travel is possible on a block with reduced electric current without proximity switch. Integrated rotational monitoring. Smooth running through dynamic switching of increment trip.

Actuation via single I/O interface, 31 position configurations and call-ups.

Control unit can be parametrised quickly and conveniently with the software. The software and manual for programming the positioning control are available as free download.

When selecting a suitable motor, using just the retaining torque is not enough, as the motor's torque decreases with the speed. It is therefore essential to select the correct motor according to the torque curve.

Temperature range:

0 °C to +50 °C.

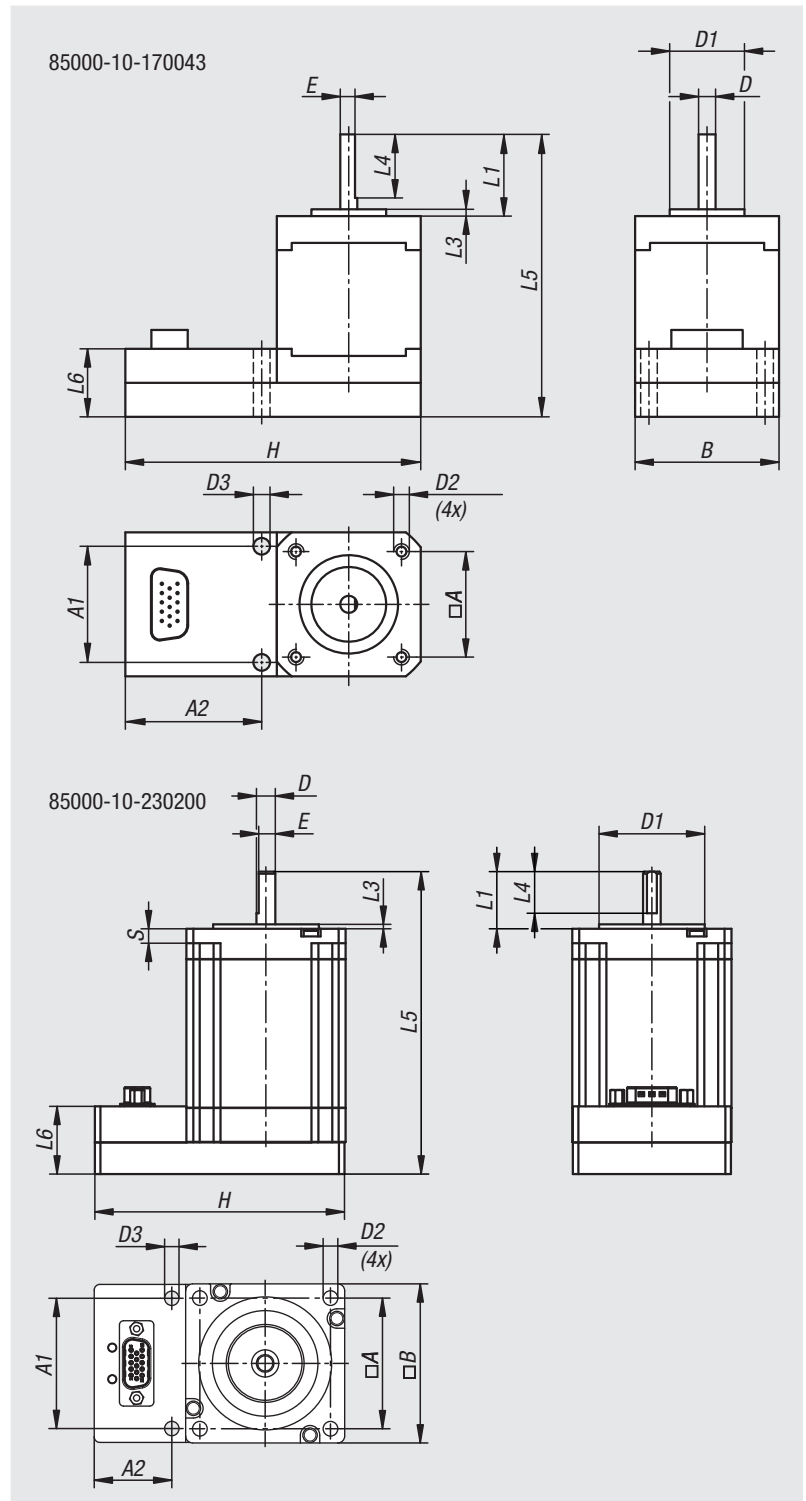

Stepper motors

with integrated positioning control

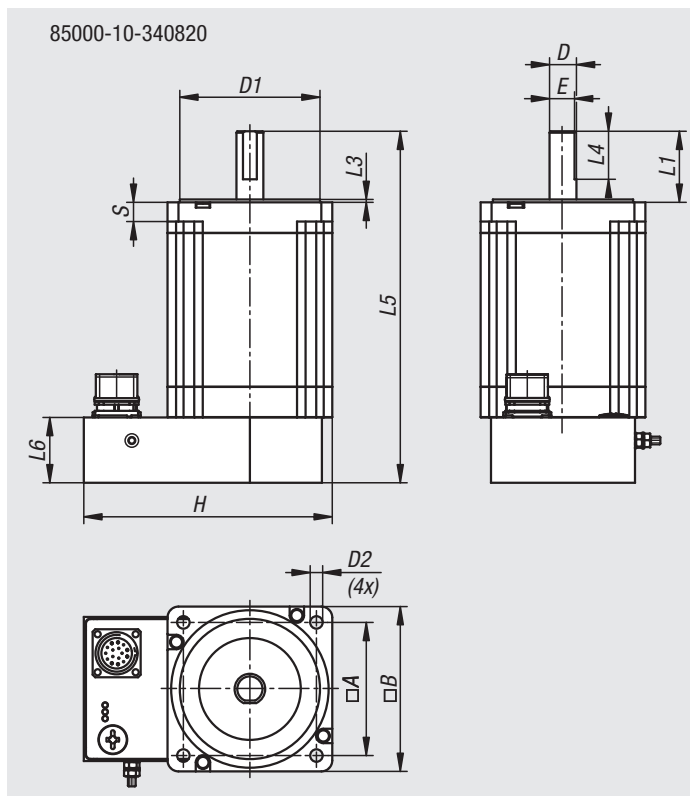

85000-10-170043
85000-10-230200

Pin	Digital I/O BAC
1	Motor supply +24 V to +48 V DC
2	Control voltage supply +24 V to +36 V DC
3	GND
4	Output "Ready" (RDY)
5	Output "Motor standing" (MOST)
6	Input "Start" or "Frequency"
7	Input I5, or direction, or reference point or analog value
8	Input 1 (binary 0)
9	Input 2 (binary 1)
10	Input 3 (binary 2)
11	Input 4 (binary 3)
12	Supply converter
13	TxD
14	RxD
15	n.c.

85000-10-340820

Pin	16-pin M23 plug, supply voltage/digital I/O
1	+24 V to +36 V DC control voltage
2	n.c.
3	+24 V to +60 V DC motor voltage
4	GND
5	Output "Motor standing" (MOST)
6	Output "Ready" (RDY)
7	Input "Start" or "Frequency"
8	n.c.
9	Input I5, or direction, or reference point or analog value
10	n.c.
11	n.c.
12	Input 1 (binary 0)
13	Input 2 (binary 1)
14	Input 3 (binary 2)
15	Input 4 (binary 3)
16	n.c.

Stepper motors

with integrated positioning control

85000-10-170043

Torque characteristic curve

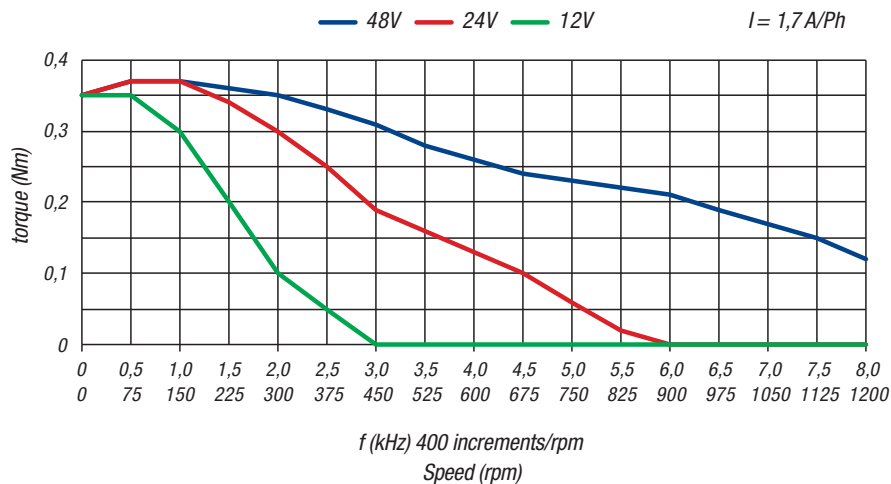

85000-10-230200

Torque characteristic curve

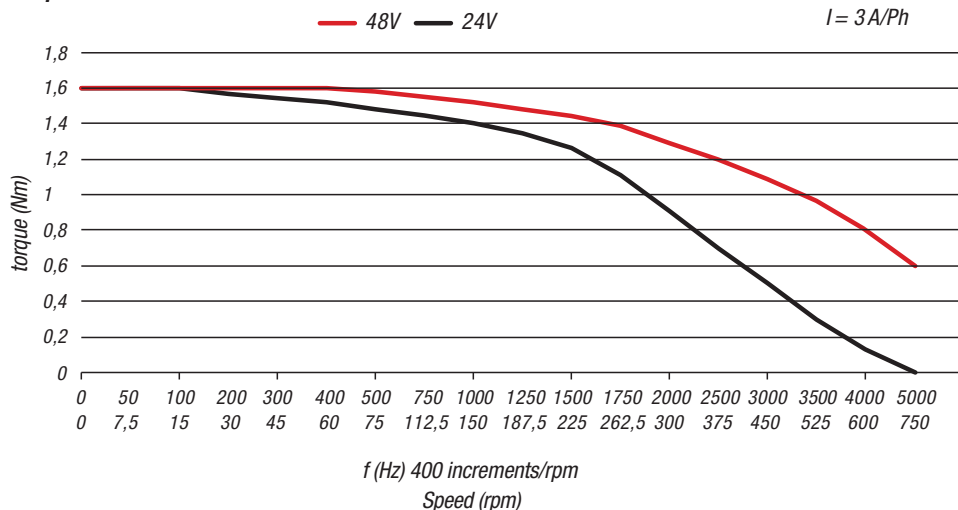

85000-10-340820

Torque characteristic curve

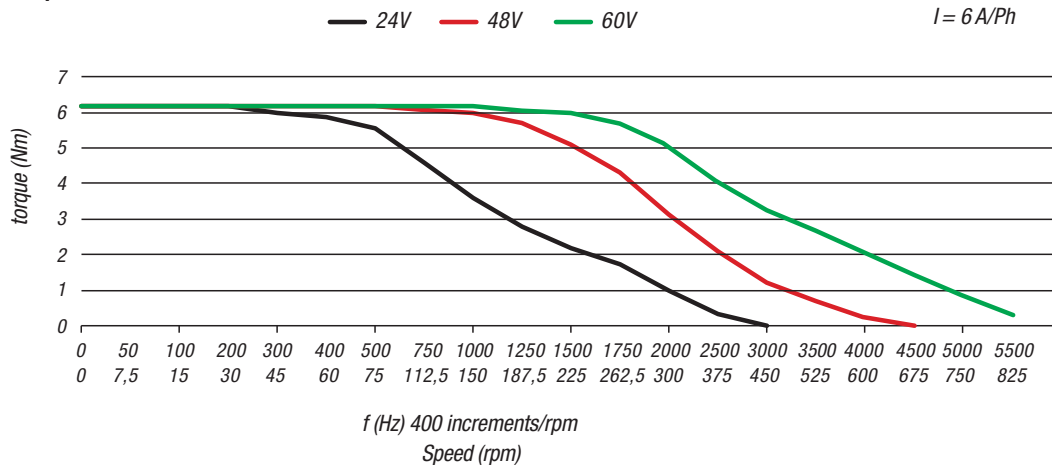

Stepper motors

with integrated positioning control

Order No.	Size	A	A1	A2	B	D	D1	D2	D3	E	H	L1	L3	L4	L5	L6	S	Control voltage VDC	Motor voltage VDC
85000-10-170043	NEMA 17	31	33	43,5	42	5	22	M03x4,5	5,2	4,5	90	20	2	15	78	24	-	+24 - +36	+24 - +48
85000-10-230200	NEMA 23	47,14	47	28	57,4	6,35	38,1	4,5	5,2	5,8	90	20,6	1,6	15	109	24,4	5	+24 - +36	+24 - +48
85000-10-340820	NEMA 34	69,6	-	-	86	14	73	6,5	-	13	129,2	37	1,6	25	183	34	9	+24 - +36	+24 - +60

Order No.	Retaining torque Nm	Phase current A	Moment of inertia kgcm ²	Interfaces
85000-10-170043	0,43	adjustable up to 1,7	0,068	DIGITAL I/O BAC, CYCLE/DIRECTION BAC
85000-10-230200	2	adjustable up to 3	0,39	DIGITAL I/O BAC, CYCLE/DIRECTION BAC
85000-10-340820	8,2	adjustable up to 6,3	3,6	DIGITAL I/O OR CYCLE/DIRECTION

Order No.	Current reduction	Inputs	Outputs	Step resolution	Encoder
85000-10-170043	AJUSTABLE	6 (+24 - +36 V DC)	2 (+24 V DC)	1/8, 1/4, 1/2, 1/1	INTEGRATED FOR MONITORING THE POSITION
85000-10-230200	AJUSTABLE	6 (+24 - +36 V DC)	2 (+24 V DC)	1/8, 1/4, 1/2, 1/1	INTEGRATED FOR MONITORING THE POSITION
85000-10-340820	AJUSTABLE	6 (+24 - +36 V DC)	2 (+24 V DC)	1/8, 1/4, 1/2, 1/1	INTEGRATED FOR MONITORING THE POSITION