

Item description/product images

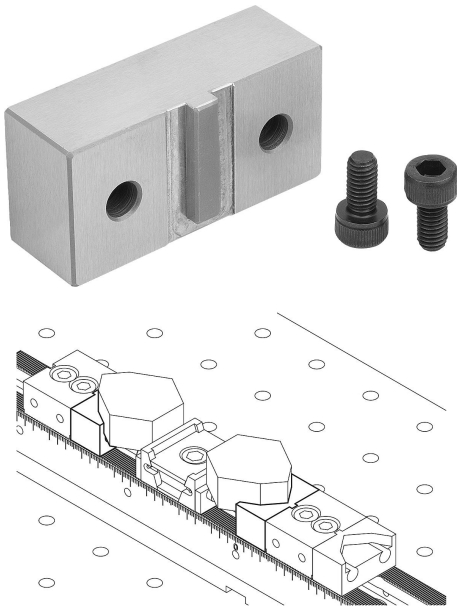

Description

Material:
Tool steel.

Version:
tempered (HRC32).

Note:
Attachment jaws are used to incorporate customer-specific workpiece contours.

Application:
The attachment jaws are screwed onto the ES and DS fixed stops.

Advantages:
Machined attachment jaws can be re-used for later series productions.

Drawings

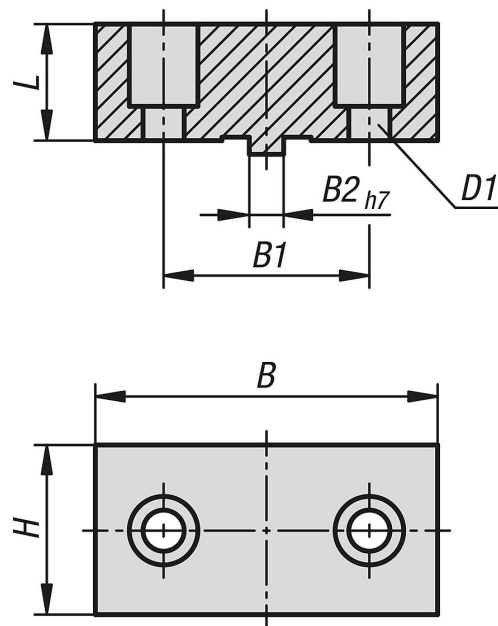

Overview of items

Order No.	suitable for system width	L	B	H	B1	B2	D1 for screw to DIN 912
41505-02-05017	50	17	50	25	30	5	M5
41505-02-05027	50	27	80	25	30	5	M5
41505-02-07219	72	19	72	40	44	8	M6
41505-02-07230	72	30	115	40	44	8	M6
41505-02-10025	100	25	100	43	64	10	M8
41505-02-10035	100	35	150	43	64	10	M8

