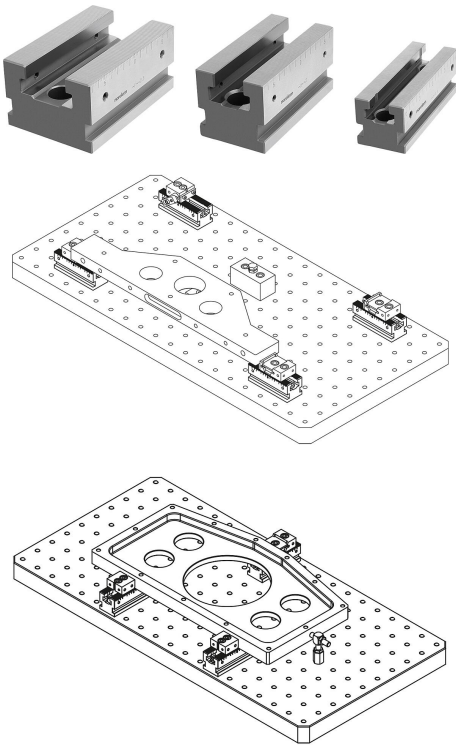

## Item description/product images

**Description****Material:**

Tool steel.

**Version:**

Hardened and ground (HRC 55 ±2).

**Note:**

The clamping rails can be fastened using various methods.

1. Lateral edge for clamping claw set. Clamping claws can be fastened at any desired position.
2. Holes for DIN cap screws.
3. One 18H7 alignment slot for T-slot tables.
4. Ø12F7 and Ø16F7 reamed holes for 50 mm grid systems.

**Technical data:**

The maximum clamping forces and the tightening torques given for the respective system widths for the 41510, 41510-10 and 41510-20 product families must be observed.

**Application:**

With the short clamping rails, clamping tasks can be implemented with low space requirements. The precision toothing enables very accurate positioning of the fixed jaws. Due to the scale on the side of the clamping rails, each position of the fixed jaws can be documented and reset identically. Stops can be mounted in the tapped holes on the side.

**Advantages:**

Universal and flexible application.

A number of short clamping rails can also be used to adapt flexibly to different clamping situations.

Drawings

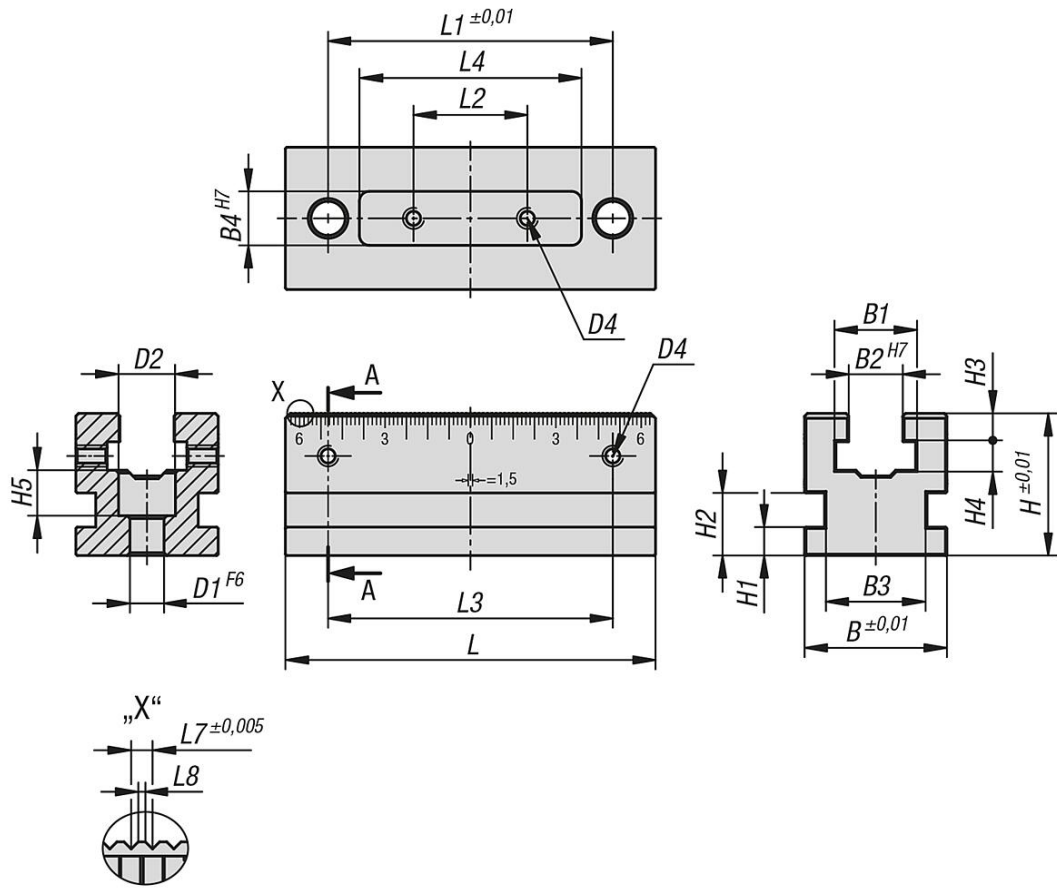

Overview of items

Order No.	B	suitable for system width	L	H	L1	L2	L3	L4	L7	L8	B1	B2	B3	B4	H1	H2	H3	H4	H5	D1	D2	D3	D4
41500-05-050130	50	50	130	50	100	40	100	77	1,5	0,5	28	19	36	18	10	22	10	10	16	12	20	M6	M6
41500-05-072140	72	72	140	72	100	40	100	77	2	0,7	42	30	58	18	14	30	15	15	22	16	26	M6	M6
41500-05-100148	100	100	148	72	100	40	100	77	2,5	0,85	58	45	86	18	14	30	15	15	22	16	26	M8	M6