

## Drill bushes flanged

DIN 172



**Material:**  
Special low carbon steel

**Version:**  
Hardened to 740 ±80 HV 10 and ground.

**Sample order:**  
nIm 08910-A0120X09  
(bush Form A D1 = 1.2 mm and L1 = 9 mm)

**Note:**  
From diameter D1 over 15 mm size increases are 0.5 mm.

**Drawing reference:**  
Form A: hole rounded one end  
Form B: hole rounded both ends

1) Chamfer for insert

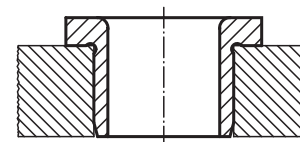
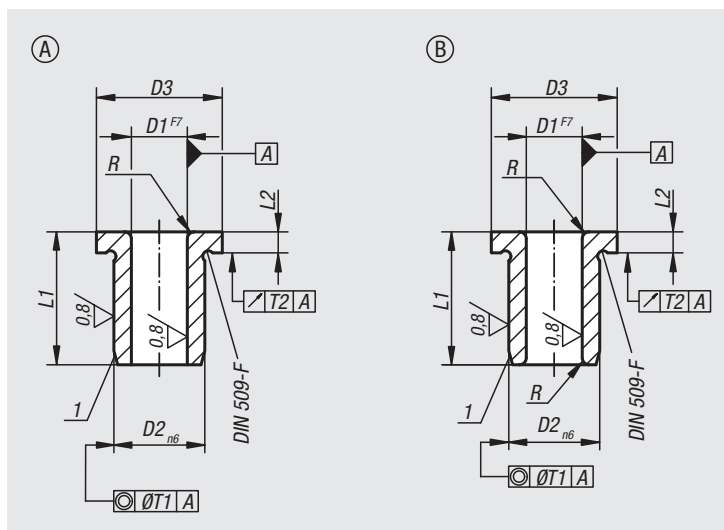

D1	D2	D3	L1	Product type	L2	R	T1	T2
from 0.4 to 0.8	3	6	6	short	2	1	0,01	0,03
from 0.9 to 1.0	3	6	6/9	short/medium	2	1	0,01	0,03
from 1.1 to 1.8	4	7	6/9	short/medium	2	1	0,01	0,03
from 1.9 to 2.6	5	8	6/9	short/medium	2	1	0,01	0,03
from 2.7 to 3.3	6	9	8/12/16	short/medium/long	2,5	1	0,01	0,03
from 3.4 to 4.0	7	10	8/12/16	short/medium/long	2,5	1	0,01	0,03
from 4.1 to 5.0	8	11	8/12/16	short/medium/long	2,5	1	0,01	0,03
from 5.1 to 6.0	10	13	10/16/20	short/medium/long	3	1,5	0,02	0,03
from 6.1 to 8.0	12	15	10/16/20	short/medium/long	3	1,5	0,02	0,03
from 8.1 to 10.0	15	18	12/20/25	short/medium/long	3	2	0,02	0,03
from 10.1 to 12.0	18	22	12/20/25	short/medium/long	4	2	0,02	0,03
from 12.1 to 15.0	22	26	16/28/36	short/medium/long	4	2	0,02	0,03
from 15.5 to 18.0	26	30	16/28/36	short/medium/long	4	2	0,02	0,03
from 18.5 to 22.0	30	34	20/36/45	short/medium/long	5	3	0,02	0,03
from 22.5 to 26.0	35	39	20/36/45	short/medium/long	5	3	0,02	0,05
from 26.5 to 30.0	42	46	25/45/56	short/medium/long	5	3	0,02	0,05
from 30.5 to 35.0	48	52	25/45/56	short/medium/long	5	3	0,04	0,05
from 35.5 to 42.0	55	59	30/56/67	short/medium/long	5	3,5	0,04	0,05
from 42.5 to 48.0	62	66	30/56/67	short/medium/long	6	3,5	0,04	0,05