

Weld-on D-rings



Material:
 Eye 1.6541 steel.
 Welding block, S355JR steel.

Version:
 D-ring forged, high tensile tempered, red plastic coated.
 Welding block forged, high tensile tempered, bright.

Sample order:
 nlm 07720-1000

Note:
 Weld-on D-rings enable quick installation.

They offer a compact design and can be loaded from all sides, with 4x safety factor against breakage.

The welding block is forged from easy to weld S355JR (St 52-3). The small knobs serve as spacers for the air gap required for fillet welding (ca. 3 mm).

The load data given in the table is clearly marked on the welding block, they apply to worst scenario cases for the lifting type shown.

Welding must be carried out by a proficient welder certified to EN 287-1.

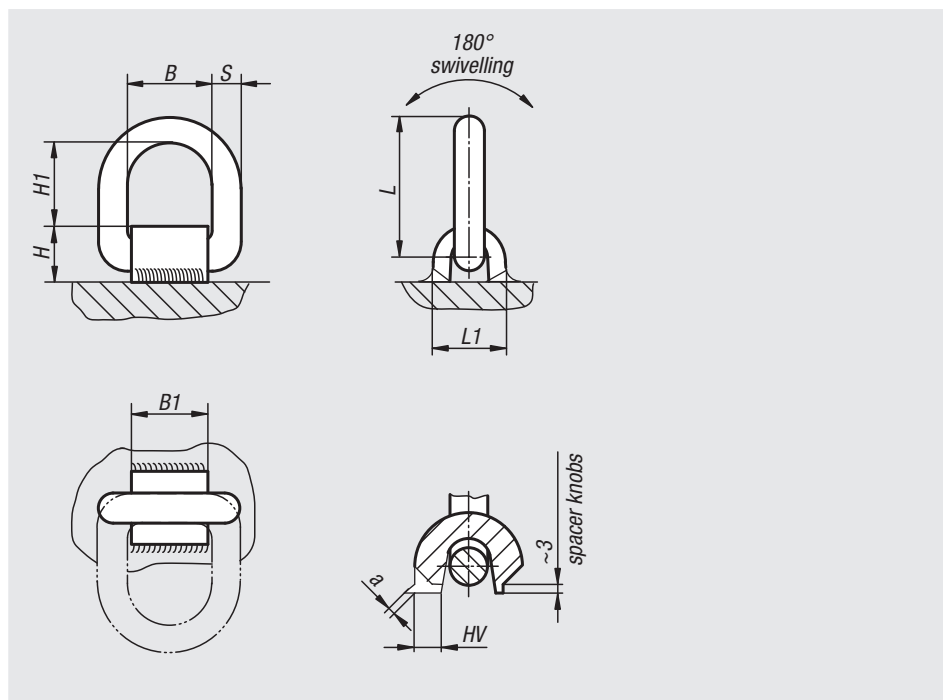

Maximum lifting weight "G" in kg for different sling types

Sling configuration	0°		90°		0°-45°		45°-60°	
	G	G	G	G	G	G	G	G
No. of slings	1	2	1	2	2	2	3 - 4	3 - 4
Sling angle \sphericalangle	0°	0°	90°	90°	0°-45°	45°-60°	0°-45°	45°-60°
07720-1***	1600	3200	1120	2240	1500	1120	2360	1600
07720-2***	3000	6000	2000	4000	2800	2000	4000	3000
07720-3***	4750	9500	3150	6300	4250	3150	6300	4750
07720-5***	8000	16000	5300	10600	7100	5300	11200	8000

Order No. without spring strip	Order No. with spring strip	B	B1	H	H1	L	L1	S	Weld seam	Permissible load kg
07720-1000	07720-1001	40	38	32	40	73	38	13	HV 5 + a3	1120
07720-2000	07720-2001	41	38	32	45	81	40	13	HV 5 + a3	2000
07720-3000	07720-3001	45	43	38	45	87	42	17	HV 8 + a3	3150
07720-5000	07720-5001	55	50	48	57	108	60	22	HV 12 + a4	5300

01000
02000
03000
04000
05000
06000
07000
08000
09000
10000
12000