

Clamp nuts

Material:

Housing carbon steel, cover aluminium.

Version:

Carbonitrided

Sample order:

nIm 04750-6012

Note:

The main feature of the mechanical clamp nut is an integrated planetary gear to simplify the manual clamping torque. After manually adjusting the clamp nut up to the workpiece the drive pinion of the planetary gear is engaged by turning the hexagonal spigot "SW1" to the right. The clamp nut is self-locking in every position. The clamp nut can be used for many clamping tasks throughout the machining field, especially for clamping parts in presses and punches.

Suitable bolts for t-slots see 07040.

The clamp nuts are supplied without t-slot bolts.

Drawing reference:

- 1) ratchet
- 2) screws for T-slots up to M24, min. grade 10.9

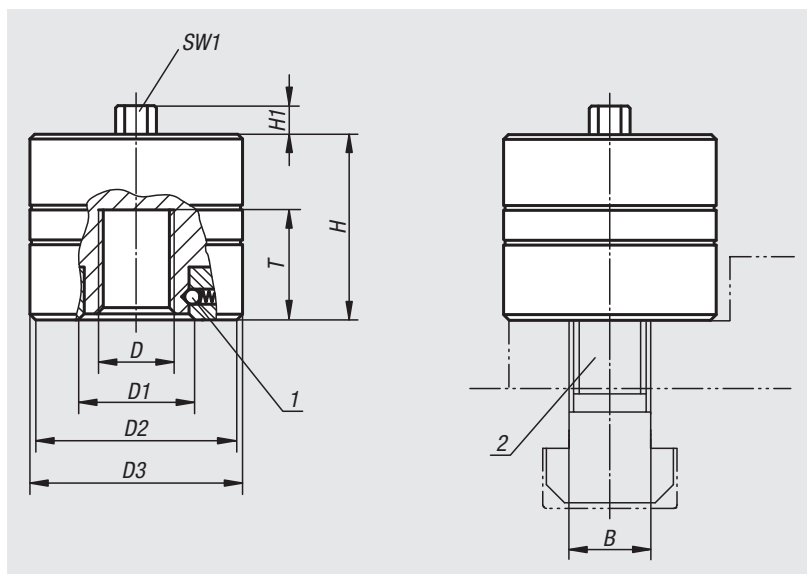

Clamp nut clamping sprockets during milling



Order No.	D	D1	D2	D3	H	H1	T min.	T max.	B	SW1	Clamping force max. kN	max. static load kN	Tightening torque max. Nm
04750-6012	M12	32	60	62	50	10	16	24	14	13	60	70	20
04750-6016	M16	32	60	62	50	10	16	24	18	13	60	120	25
04750-6020	M20	32	60	62	50	10	16	24	22	13	60	120	30
04750-10016	M16	42	71	73	70	10	25	35	18	15	100	130	35
04750-10020	M20	42	71	73	70	10	25	35	22	15	100	200	40
04750-10024	M24	42	71	73	70	10	25	35	28	15	100	200	45