

Side clamp

with cam



Material:

Carbon steel.

Version:

Black oxidised.

Sample order:

nIm 04515-101

Assembly:

1. Screw the locking screw into the collar bush, fixture clamp and clamping unit and screw onto the baseplate.
2. The workpiece is clamped by tightening the fixture clamp with a spanner.

Advantages:

- Compact design
- Quick and easy clamping of components
- Pull-down effect

Drawing reference:

- 1) Locking screw
- 2) Collar bush
- 3) Fixture clamp
- 4) Clamping unit

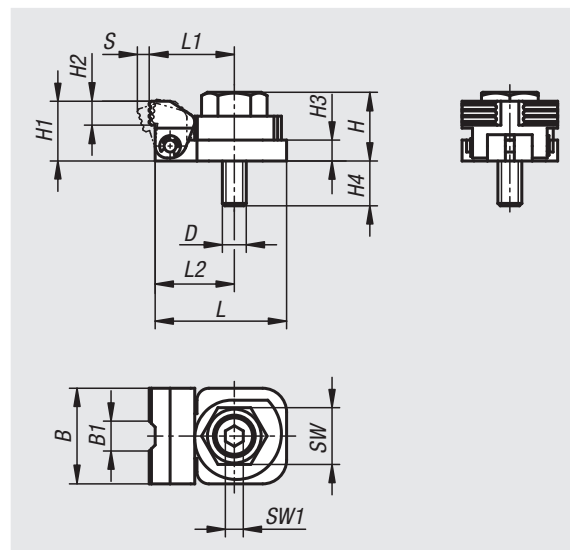
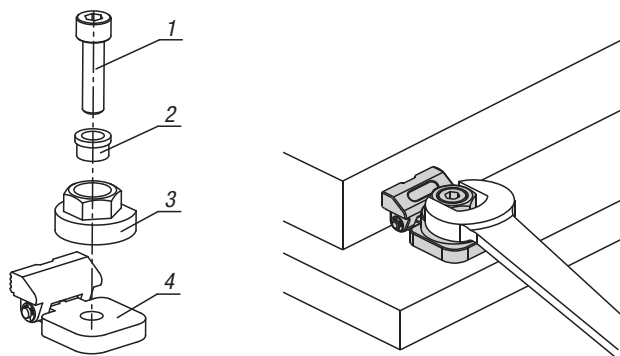

Order No.	B	B1	D	H	H1	H2	H3	H4	L	L1	L2	SW	SW1	Travel S	Clamping force kN	Tightening torque max. Nm
04515-081	32	10	M8	23	20	8	7	15	44	28,5	26,5	19	6	4	3,5	45
04515-101	40	12	M10	29	25	10	9	16	54	35	33	24	8	5	5,5	55
04515-121	46	14	M12	35	30	12	11	17	62	39,5	37,5	27	10	5,5	7	70