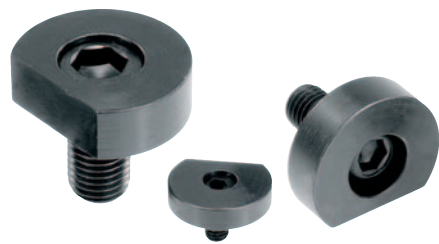

Fixture clamps machinable

Material:

Cam screw alloyed steel.
Clamping disc steel.

Version:

Cam screw and clamping disc black oxidised.

Sample order:

nIm 04431-06

Note:

These fixture clamps have a round washer that can be machined to suit the contour of the workpiece being clamped. This allows positive clamping for round, contoured or fragile workpieces. The flat edge is the same distance from the screw centre as our hexagonal fixture clamps 04435 allowing an interchange between the two. "A" = distance from workpiece to screw centre (cam screw).

"D1 min." = maximum depth of contour.

On request:

Replacement cam screws.

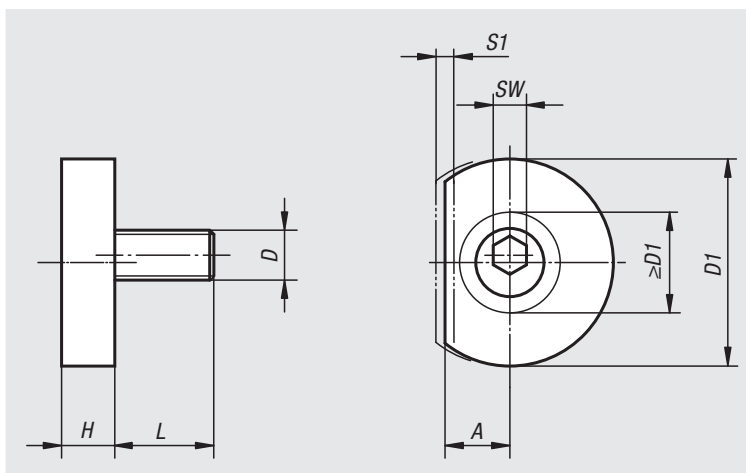

Order No.	A	D	D1	D1 min.	H	L	SW	S1 (travel)	Clamping force kN
04431-06	7,8	M6	24,9	12,1	6,4	11,9	4	1,01	3,3
04431-10	10,2	M10	31,2	17,2	8,9	18	7	1,52	8,9
04431-12	12,7	M12	37,6	22,4	11,4	22,9	8	2,03	17,8
04431-16	15	M16	43,9	26,1	14	28,6	12	2,54	26,7