

# Pull clamps

pneumatic

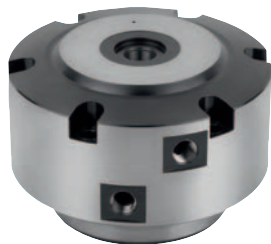

**Material:**  
Carbon steel.

**Version:**  
Clamping element hardened, ground and black oxidised.

**Sample order:**  
nlm 04403-40075

**Note:**  
Pneumatic pull clamps are used to clamp workpieces and fixtures.  
The draw bolts are screwed onto the workpiece or fixture.

#### Clamping procedure:

Open the clamping element by applying compressed air to the „open“ connection.  
Close clamping element (for clamping) by applying compressed air to the „close“ connection.

The third connection (D5) is used to blow out and clean the seating face. It can also be used to ensure the workpiece is correctly seated, or to ease lifting the workpiece off after the opening procedure.

The system can also be used as a zero-point clamping system.

The clamping forces indicated are based on 0.5 MPa.

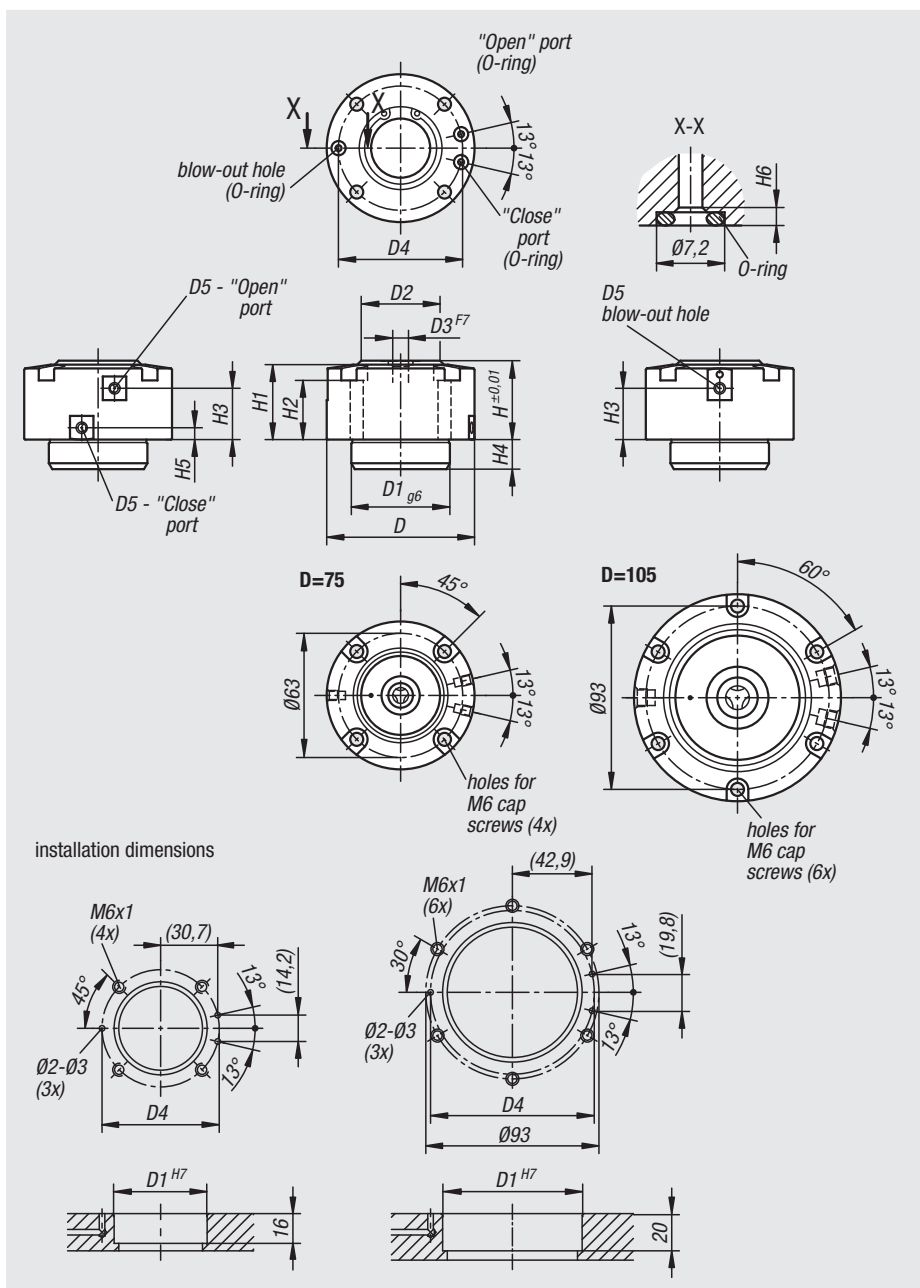

Order No.	D	D1	D2	D3	D4	D5	H	H1	H2	H3	H4	H5	H6	Clamping force kN	Operating pressure MPa
04403-40075	75	50	40	8	63	M5	40	38	30	26	15	6	1,9	1	0,3 - 1,0
04403-50105	105	75	63	12	88	G 1/8	50	47	35	31	19	10	1,9	2,5	0,3 - 1,0

# Pull clamps

pneumatic

### Mounting instructions:

#### Using the side ports:

- Seal the lower ports with the O-rings provided.
- Check that no air coming is escaping from here.

#### Using the lower ports:

- Fit the O-rings provided into the lower port.
- The side ports must be closed.

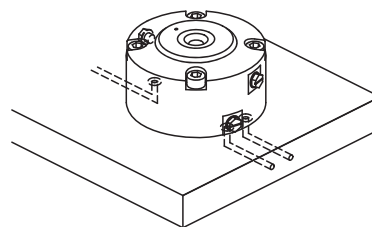
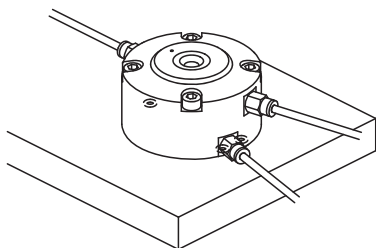

### Positioning the workpiece

Clamping with pull clamp and draw bolt

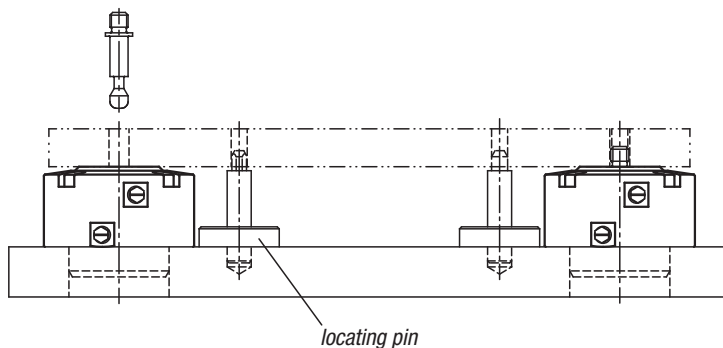

Simultaneous clamping and positioning of a workpiece

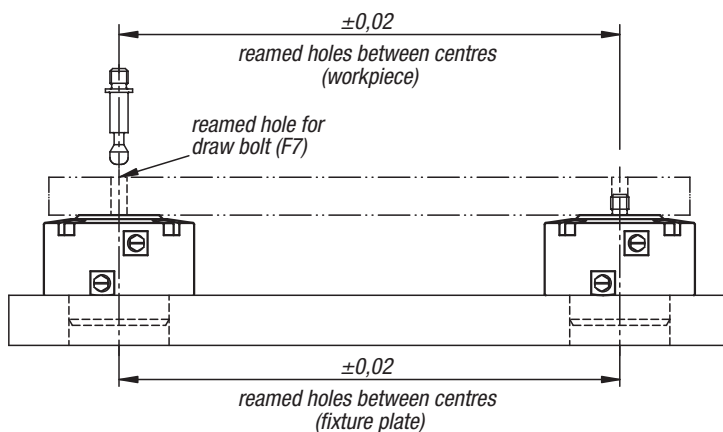

### Performance curve

