

Swing clamp

pneumatic



Material:
Carbon steel.

Version:
Clamping element nickel-plated.
Clamping bolt tempered and nickel-plated.

Sample order:
nlm 04365-13945

Note:
The pneumatic swing clamp is suitable for clamping workpieces from above. The swivel and clamping function occurs pneumatically. The swivel function enables unobstructed insertion and removal of the workpiece. Optimum accessibility to the workpiece is guaranteed. The foot of the housing offers universal fastening possibilities, enabling the swing clamp to be optimally aligned with the workpiece being clamped. The swing clamps are available in left or right swivelling versions. Pneumatic swing clamps can also be placed in multiple positions on the workpiece and operated in a particular order. They can be controlled manually or automatically.

The clamping force and retaining force indicated are based on 0.5 MPa.

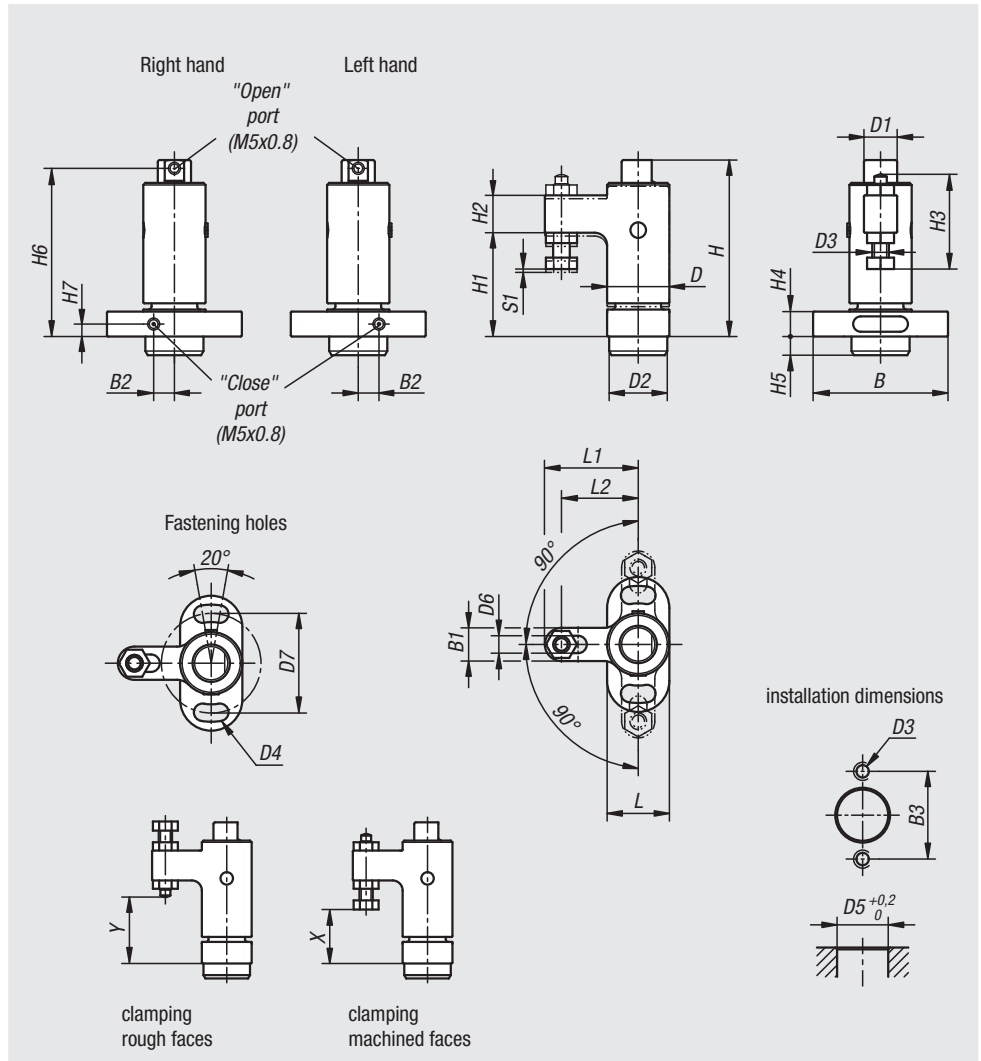

Performance curve

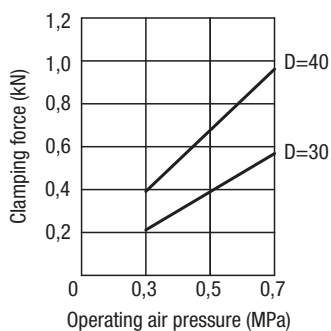

Swing clamp

pneumatic

Setting the distance between the workpiece and thrust screw:

The distance between thrust screw and workpiece should be ca. half of the clamping travel (S1).

The clamping arm swivels in horizontally.

Carry out the following steps to set the thrust screw correctly.

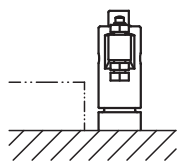

1. Open the clamp by applying compressed air to the "open" port.

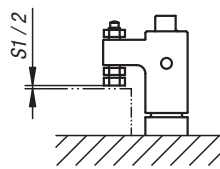

2. Manually swivel the arm to the clamping position. Set the distance between the thrust screw and the workpiece top face to half the clamping travel (S1).

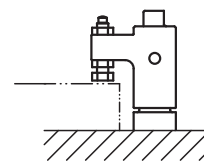

3. Secure the thrust screw in place using locknuts.

Order No.	Version 1	B	B1	B2	B3	D	D1	D2	D3	D4	D5	D6	D7	H	H1	H2
04365-13945	right	65	16	10	48	30	16	28	M8	8,4	28	8,4	48	85	50	18
04365-03945	left	65	16	10	48	30	16	28	M8	8,4	28	8,4	48	85	50	18
04365-15155	right	85	20	13	64	40	22	35	M10	10,5	35	10,4	64	106	65	22
04365-05155	left	85	20	13	64	40	22	35	M10	10,5	35	10,4	64	106	65	22

Order No.	H3	H4	H5	H6	H7	L	L1	L2	S1 (travel)	F=Retaining force N	Holding force F kN	Operating pressure MPa	X min.	X max.	Y min.	Y max.
04365-13945	45,5	12	9	81	6	30	45	37	1,2	400	0,8	0,3 - 0,7	32,5	39	33,5	40
04365-03945	45,5	12	9	81	6	30	45	37	1,2	400	0,8	0,3 - 0,7	32,5	39	33,5	40
04365-15155	57	15	11	101	8	40	55	45	1,6	650	1,3	0,3 - 0,7	41,5	51	44	53,5
04365-05155	57	15	11	101	8	40	55	45	1,6	650	1,3	0,3 - 0,7	41,5	51	44	53,5