

# Machinable collets

pneumatic



**Material:**

Chuck high-carbon steel, nickel-plated.  
Collet high-strength aluminium, blue anodised.

**Sample order:**

n1m 03178-10-1065090

**Note:**

The pneumatic collet system consists of a chuck and a machinable collet.  
The chuck can be screwed onto fixtures according to the mounting dimensions.

**Clamping procedure:**

The collet is opened by applying compressed air to the „open“ port.

The collet is closed (for clamping) by applying compressed air to the „close“ port.

The pneumatic connections can be screwed on either from below or from the side. If the air is connected from below, the side ports must be closed.

**Machining the collet for external clamping:**

The negative form of the workpiece to be clamped is machined into the collet. Free-form and asymmetrical contours are possible.

Different workpieces can be clamped quickly and securely by simply exchanging the collet.

The collet can be milled down to height H2. This enables multiple workpiece contours to be machined into one collet.

Repeat accuracy for workpiece: +/-0.03

Repeat accuracy after replacing the collet +/- 0.02

The collet radial clamping travel is 0.15 mm per clamping segment.

To prevent damage the collet should not be tightened without a workpiece or clamping ring in place.

The operating air pressure should lay between 0.45 - 0.55 MPa.

The clamping forces indicated are based on 0.5 MPa.

**Accessories:**

Clamping ring for machining the contour.

O-ring.

Locating pin.

Clamping screw for collet.

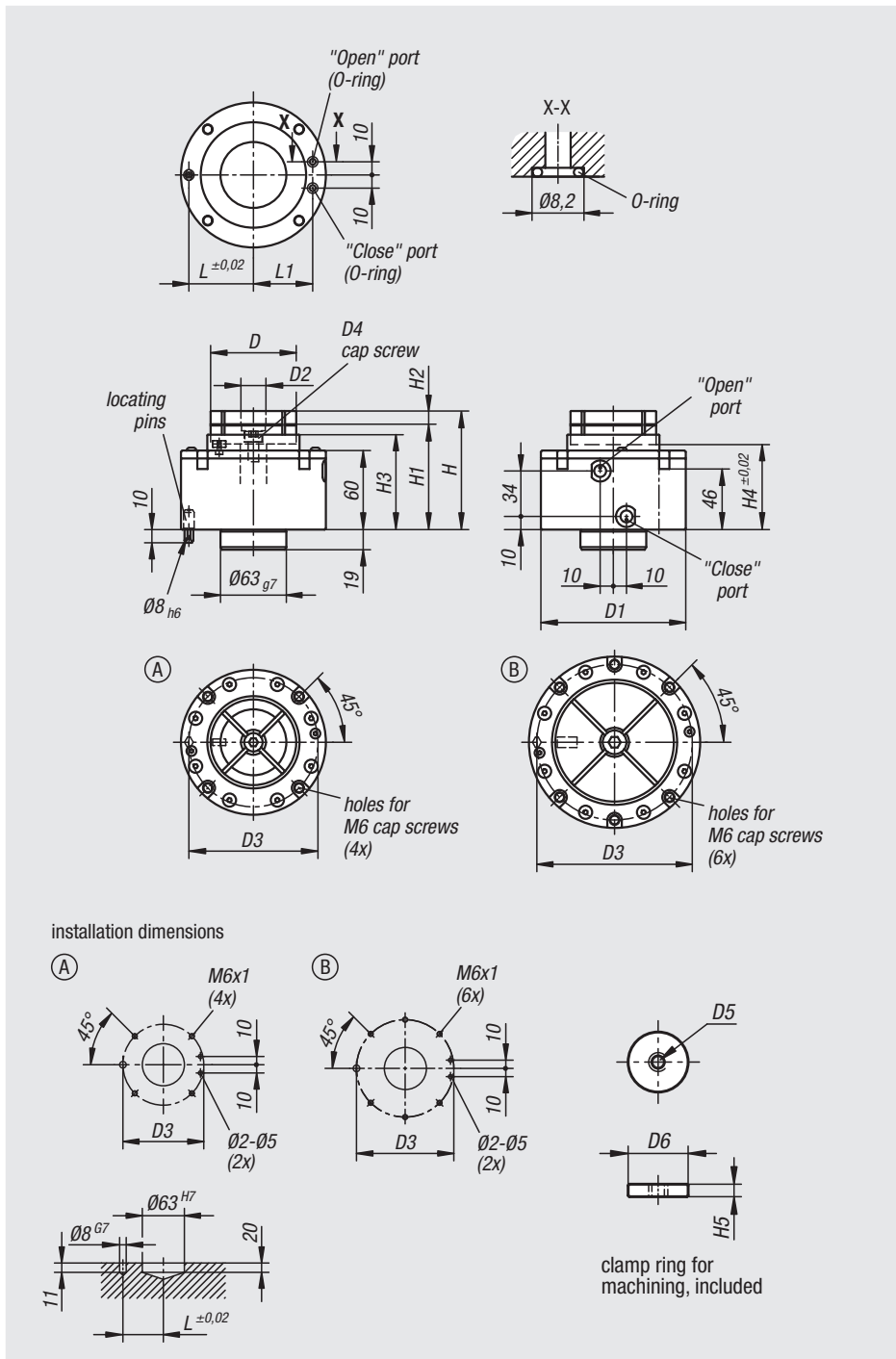

Order No.	Form	D	D1	D2	D3	D4	D5	D6	H	H1	H2	H3	H4	H5	L	L1	Operating pressure MPa	Clamping force N
03178-10-1065090	A	65	110	19	98	M8	M4	18	90	80	10	72	65	4	49	45	0,5	4000
03178-10-1090100	B	90	130	23	118	M10	M5	22	100	85	15	74	66	6	59	55	0,5	6000

# Machinable collets

pneumatic

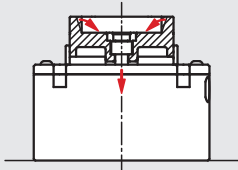

Applying compressed air draws the cylinder down. The 4 clamping segments move inwards and clamp the workpiece.

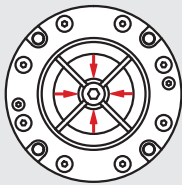

### Using the side ports:

- Seal the lower ports with the O-rings provided.
- Check that no air escaping from here.

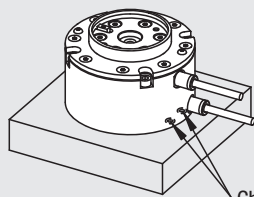

Check that the lower ports are sealed.

### Using the lower ports:

- Fit the O-rings provided into the lower ports.
- The side ports must be closed.

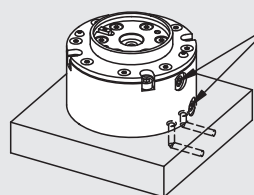

Seal the air connections and check them for tightness.

Different workpiece shapes can be machined into the collets.

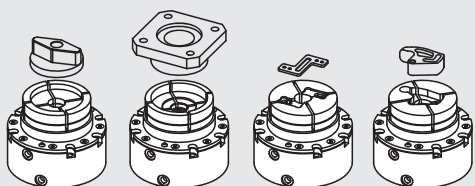

### Mounting the collet:

When mounting the collet, make sure that air is connected to the "open" connection. The cylinder and fastening screw are loose.

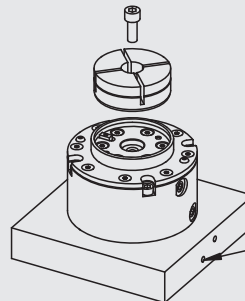

Note:  
Connect air to the "open" port

### Machine the collet:

Insert the clamping ring into the collet. (A screw can be used as an insertion aid)

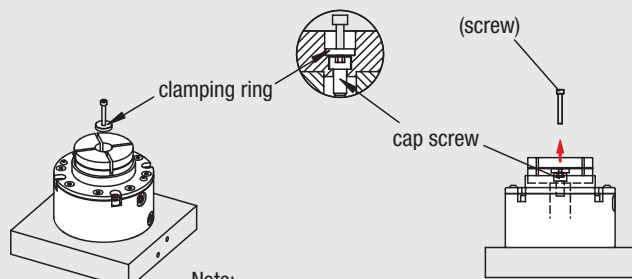

Note:  
Position the clamping ring over the fastening screw of the collet.

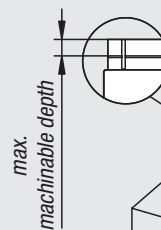

Clamp the collet over the "close" port.

Machine the collet to suit to the workpiece shape.

### Clamp the workpiece:

After machining the collet, remove the clamping ring. Insert the workpiece and apply air to the "close" port to clamp it.

