

Item description/product images

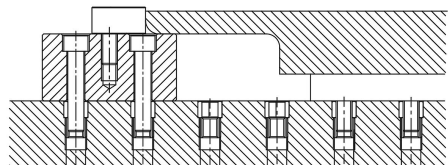

Description

Material:
Carbon steel.

Version:
Tempered, black oxidised.
Contact faces ground.

Note:
Support blocks are for placing under long workpieces to prevent bending during machining or clamping. The tapped hole is for mounting fixture elements between the grid holes.

Drawings

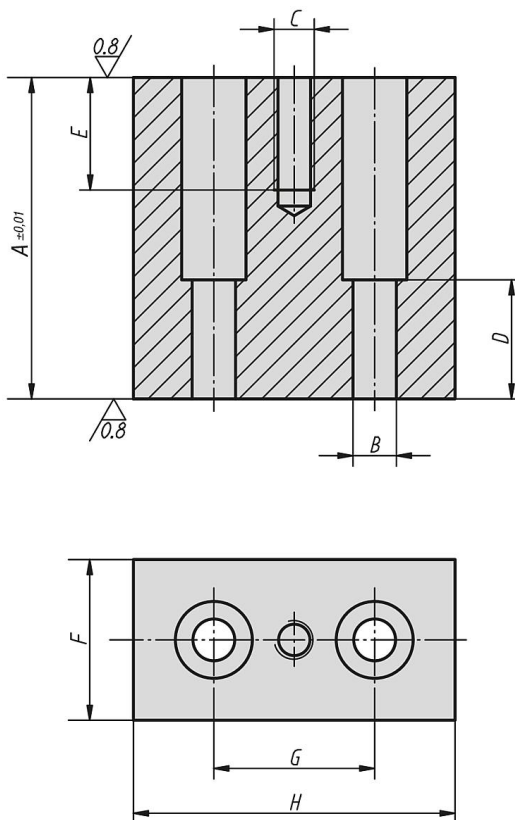

Overview of items

Order No.	A	B hole for DIN 912 screw	C	D	E	F	G	H
02392-05-36012020	20	M12	M12	7	20	50	50	100
02392-05-36012025	25	M12	M12	12	25	50	50	100
02392-05-36012032	32	M12	M12	19	32	50	50	100
02392-05-36012040	40	M12	M12	27	40	50	50	100
02392-05-36012050	50	M12	M12	37	35	50	50	100
02392-05-36012063	63	M12	M12	37	35	50	50	100

Overview of items

Order No.	A	B hole for DIN 912 screw	C	D	E	F	G	H
02392-05-36012080	80	M12	M12	37	35	50	50	100
02392-05-36012100	100	M12	M12	37	35	50	50	100
02392-05-36012125	125	M12	M12	37	35	50	50	100
02392-05-36016025	25	M16	M16	8	25	50	50	100
02392-05-36016032	32	M16	M16	15	32	50	50	100
02392-05-36016040	40	M16	M16	23	40	50	50	100
02392-05-36016050	50	M16	M16	33	35	50	50	100
02392-05-36016063	63	M16	M16	46	35	50	50	100
02392-05-36016080	80	M16	M16	46	35	50	50	100
02392-05-36016100	100	M16	M16	46	35	50	50	100