

Support element

**Material:**

Main body hardened steel.
Housing aluminium.

Version:

Main body nitrated, manganese phosphated and ground.
Housing red anodised.

Sample order:

nIm 02340-0508

Note:

The support element is for supporting overhanging workpiece parts. It prevents vibration and bending during machining.

Method of operation:

1. Turn the cam screw (hex. socket SW 6) on the side of the housing, the support bolt will move out under light spring load until it makes contact with the workpiece.
2. Continue to turn to „lock“ position. The support bolt locks without changing position.
3. Turn the cam screw in the opposite direction and the support bolt will unlock. Continue turning to the „unlock“ position and the support bolt will slide back into the body.

Assembly:

Mount the support element to the fixture using the two M6 tapped holes.

Alternatively: Exchange the M12x10 plug screw for a M12x30 grub screw and mount the support directly onto the machine table with a T-nut.

For safe operation the M12 tapped hole must always be filled. It is possible to countersink the support element by 16 mm. Various rest pads can be mounted into the M8 tapped hole on the support bolt.

Supplied with M12x30 grub screw and M12 nut for T-slots (DIN 508).

Drawing reference:

- 1) grub screw M12x30 DIN 913 (exchangeable)
- 2) nut for T-slots M12x14 DIN 508

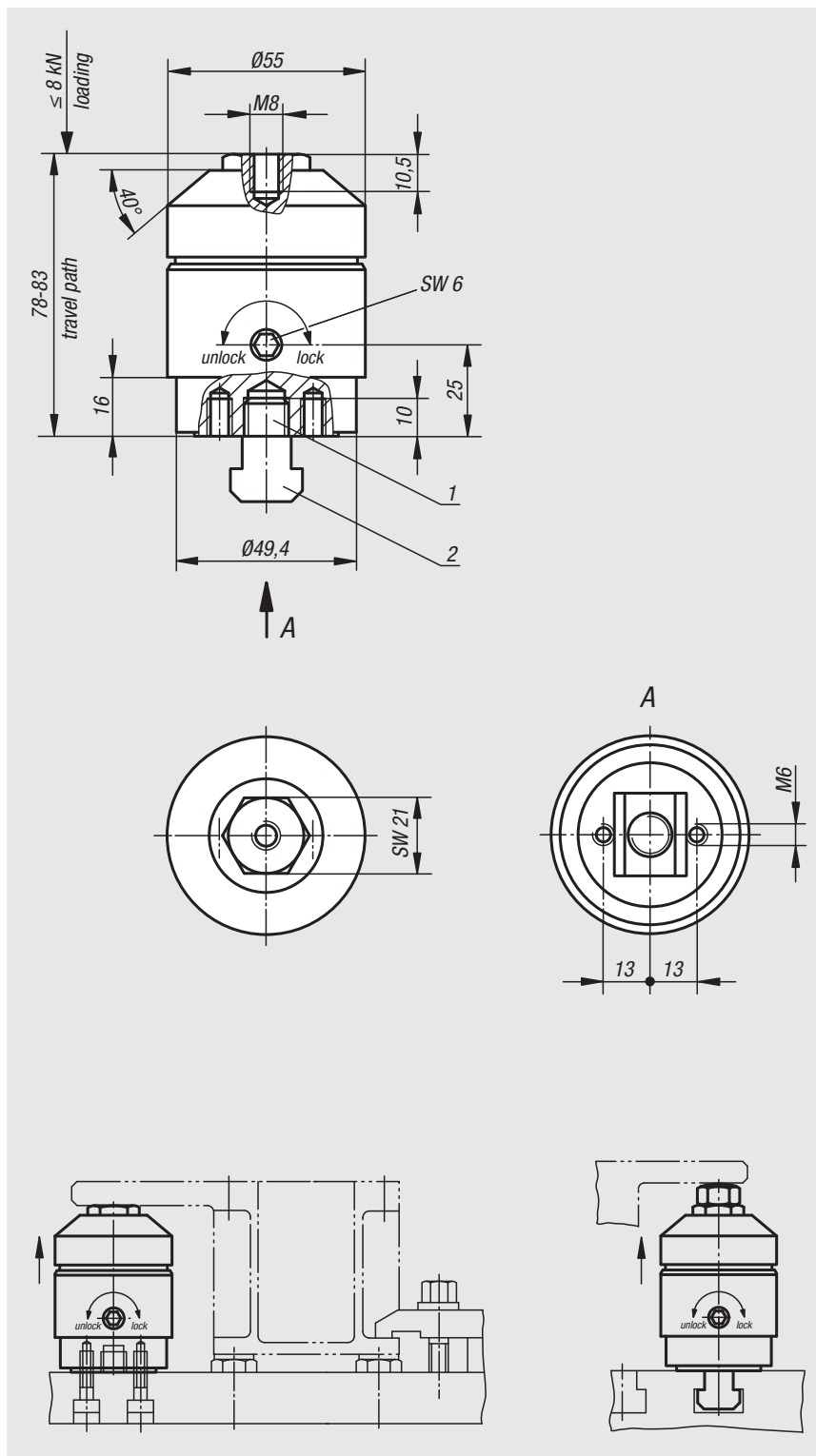

Order No.

Load
capacity
N

Travel path

02340-0508

8000

5 mm