

# Locating pins and rest pads

DIN 6321 (Issue 1973)



**Material:**  
Tool steel.

**Version:**  
Hardened and ground.

**Sample order:**  
nlm 02020-212

**Note:**

Rest pads Form A are supports for workpieces and fixtures.

Locating pins Form B are for positioning workpieces and fixture components in reamed holes.

The flattened Form C can be used to bridge tolerances in hole spacing or to secure the part to be positioned in one direction only.

Form A and B can also be used as hardened stops and as fixture feet.

For similar pins see 03120, 03130, 03140 and 03150.

**Drawing reference:**

Form A: Rest pad

Form B: Cylindrical locating pin

Form C: Flattened locating pin

For other dimensions see Form A.

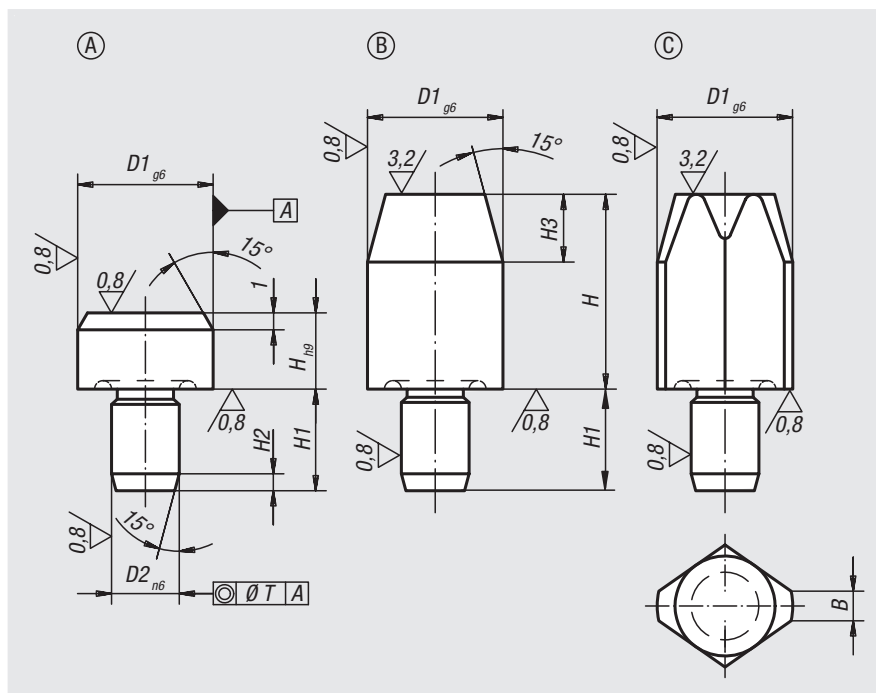

## Rest pads, Form A

Order No. without centre bore	D1	D2	H	H1	H2	T
02020-106	6	4	5	6	1,2	0,02
02020-110	10	6	6	9	1,6	0,02
02020-116	16	8	8	12	2	0,04
02020-125	25	12	10	18	2,5	0,04

## Locating pin cylindrical, Form B

Order No. short	Order No. long	D1	D2	H	H1	H2	H3	T
02020-206	02020-306	6	4	7/12	6	1,2	4	0,02
02020-208	02020-308	8	6	10/16	9	1,6	6	0,02
02020-210	02020-310	10	6	10/18	9	1,6	6	0,02
02020-212	02020-312	12	6	10/18	9	1,6	6	0,02
02020-216	02020-316	16	8	13/22	12	2	8	0,04
02020-220	02020-320	20	12	15/25	18	2	9	0,04
02020-225	02020-325	25	12	15/25	18	2,5	9	0,04

## Locating pin rhombic, Form C

Order No. short	Order No. long	B	D1	D2	H	H1	H2	H3	T
02020-410	02020-510	2,5	10	6	10/18	9	1,6	6	0,02
02020-412	02020-512	2,5	12	6	10/18	9	1,6	6	0,02
02020-416	02020-516	3,5	16	8	13/22	12	2	8	0,04
02020-420	02020-520	5	20	12	15/25	18	2	9	0,04
02020-425	02020-525	5	25	12	15/25	18	2,5	9	0,04
02020-406	02020-506	1	6	4	7/12	6	1,2	4	0,02
02020-408	02020-508	1,6	8	6	10/16	9	1,6	6	0,02

