

Tombstones, grey cast iron, double-sided with UNILOCK zero-point clamping system

Item description/product images

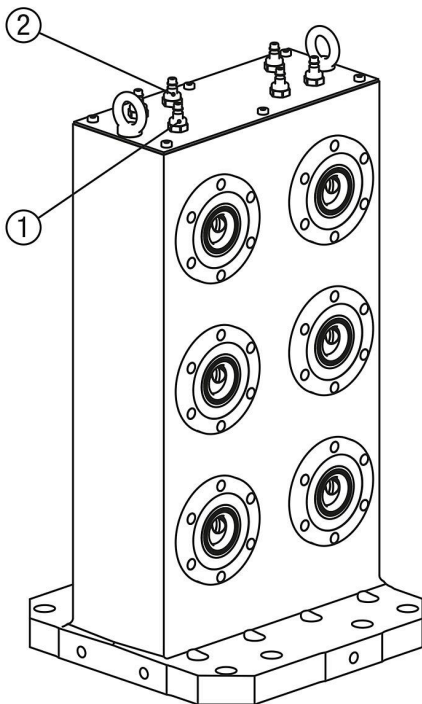

Description

Product description:

Double-sided tombstone with integrated UNILOCK clamping modules EFM 138. The integrated clamping modules enable the rapid clamping or exchange of clamping equipment and fixtures on the tombstone. Set-up times are reduced and machine running times increased.

Material:

Tombstone GJL 300.

Clamping module case-hardening steel.

Version:

Tombstone contact faces precision machined.

Clamping module contact faces hardened and ground.

Note:

These tombstones conform to machine tables for machine tools acc. to DIN 55201 and JIS6337-1980.

The clamping modules are actuated via a central pneumatic connection.

The high clamping forces are generated via the integrated spring package (the unit clamps while not under pressure).

Clamping is released pneumatically.

The following clamping forces are possible with the UNILOCK clamping bolt in conjunction with M10, M12, M16 fastening screws:

- Clamping force (M10) 35,000 N/module
- Clamping force (M12) 50,000 N/module
- Clamping force (M16) 75,000 N/module

Clamping force with DIN EN ISO 4762 -12.9 cap screws

Clamping bolts may only be clamped in conjunction with a mounted interchangeable unit in the clamping module.

Temperature range:

+5 °C to +60 °C.

Supplied with:

- Tombstone.
- Transport screws.
- Operating instructions.

Accessory:

- UNILOCK clamping bolts K0967.
- UNILOCK interchangeable subplates for zero-point clamping system K1218.
- UNILOCK protective bolts for clamping module K1010.
- UNILOCK protective plugs for clamping module K1010.

Drawing reference:

- 1) Open air port G1/8
- 2) Turbo function air port G1/8

Tombstones, grey cast iron, double-sided with UNILOCK zero-point clamping system

Drawings

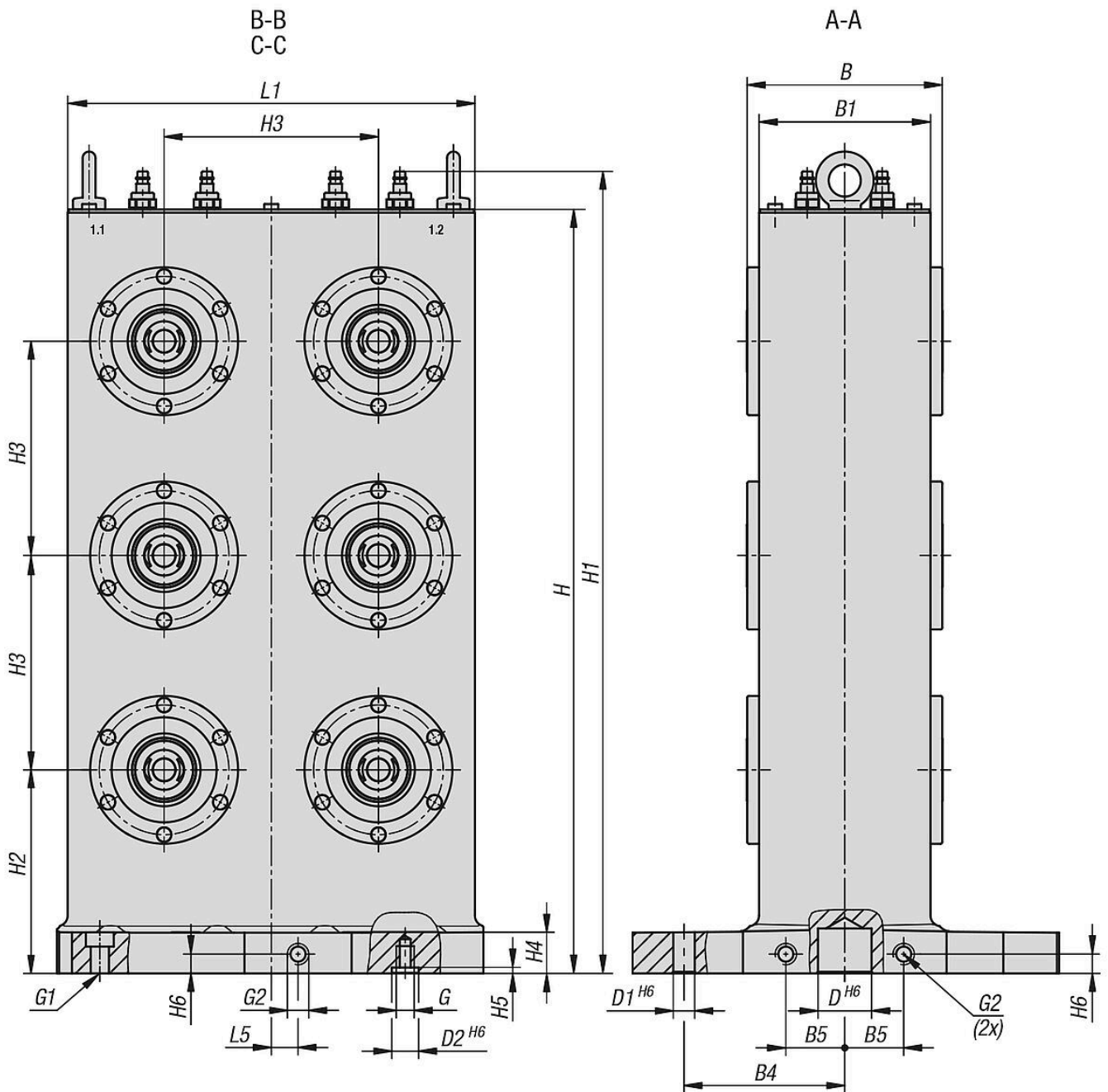

Tombstones, grey cast iron, double-sided with UNILOCK zero-point clamping system

Drawings

400x400

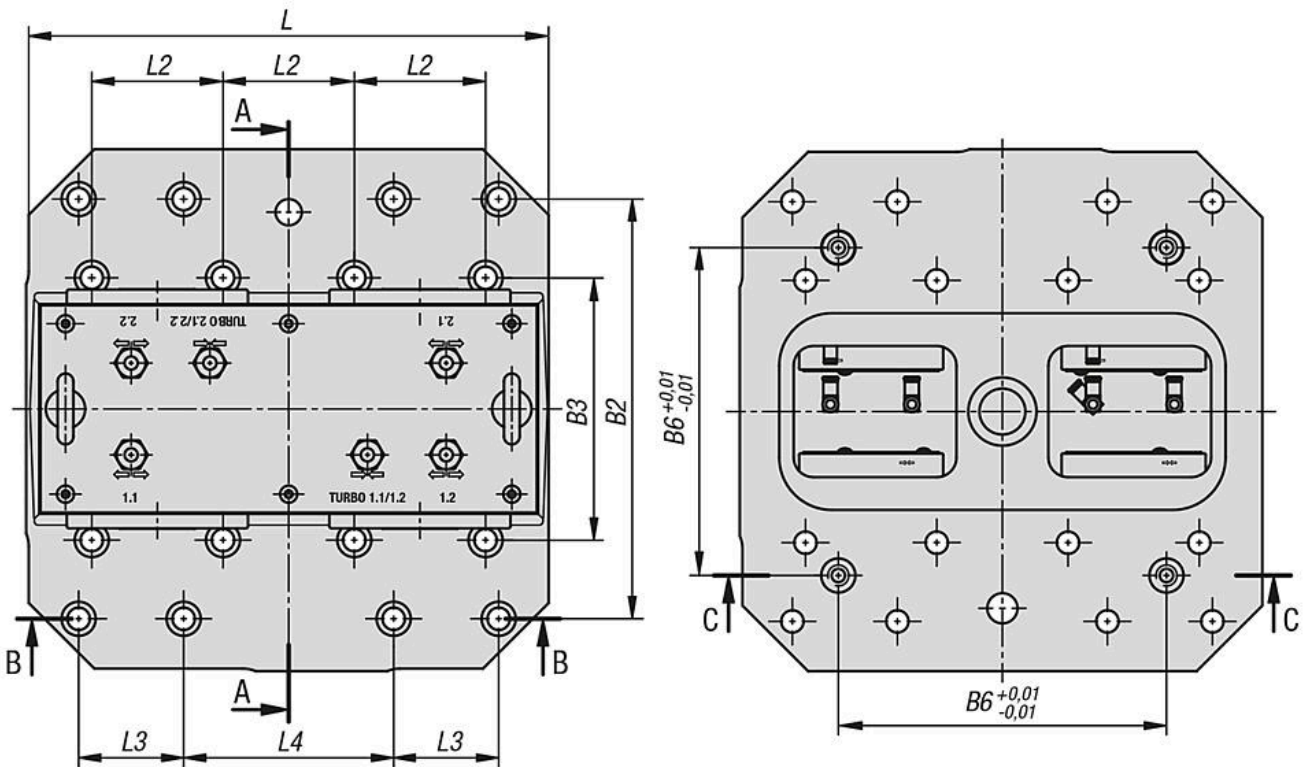

500x500

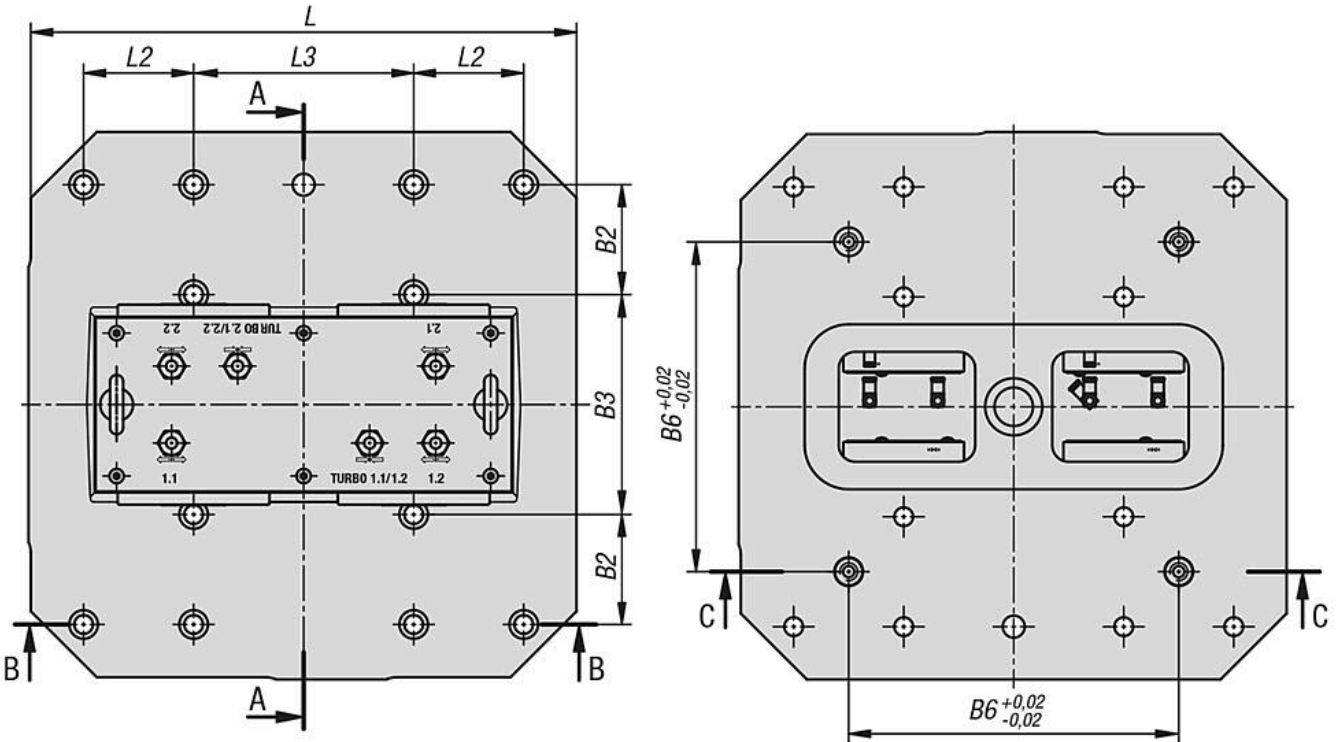

Overview of items

Tombstones, grey cast iron, double-sided with UNILOCK zero-point clamping system

Tombstones, grey cast iron, double-sided with UNILOCK zero-point clamping system

Overview of items

Order No.	Version 2	L	H	B	B1	B2	B3	B4	B5	B6	D	D1	D2	G	G1	G2
K2361.138122004070	with zero point clamping modules	400	713	182	160	320	200	150	55	250	50	20	25	M12	M16	M16
K2361.138122005070	with zero point clamping modules	500	713	182	160	100	200	200	75	300	50	20	25	M12	M16	M16

Order No.	H1	H2	H3	H4	H5	H6	L1	L2	L3	L4	L5	Retraction force with turbo kN
K2361.138122004070	748,5	190	200	40	5,5	18	380	100	80	160	25	24
K2361.138122005070	748,5	190	200	40	5,5	18	380	100	200	-	25	24

Order No.	Item	Version 1	Version 2	Form definition
K2361.138122004070	Angle plate	double sided	with zero point clamping modules	-
K2361.138122005070	Angle plate	double sided	with zero point clamping modules	-