

Fixed stop with grip insert for draw-down clamping system

Item description/product images

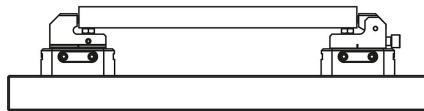
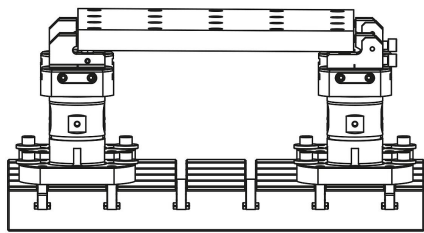
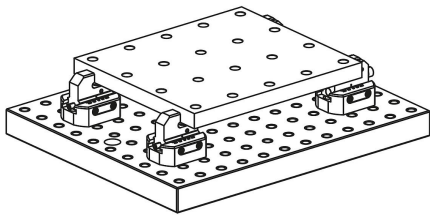

Description

Product description:

Fixed stop with grip insert for pre-machining for direct clamping and for machining blanks.

Material:

Steel.

Version:

Body black oxidised.
Grip insert hardened.

Note:

The fixed stop with grip insert is used as a counterpart for the clamping element with grip insert K2195. The extremely sturdy structure and compact design make the fixed stop suitable for pre-machining for direct clamping (OP10) with the 5-axis modular clamping system and for the rough part clamping of any plates and other workpieces.

Any workpiece size can be clamped thanks to the two system sizes and the infinitely adjustable clamping system.

The clamping height of the workpiece can be flexibly adjusted using various positioning feet and the fine adjustment.

The interface for grid plates (grid size 40/50) and for the UNILOCK zero-point clamping system are integrated as standard.

Advantages:

- Horizontal adjustment.
- Various workpiece seating heights possible.
- Integrated fine adjustment for clamping height.

Supplied with:

- 1 fixed stop with grip insert.
- 1 positioning foot K0298.2081.

Accessory:

- Positioning foot K0298.
- Adapter plate for draw-down clamping system K2199.
- Adapter ring K2200.

Drawing reference:

- 1) Caution: Risk of deformation!
No clamping claws may be applied in this area!

Fixed stop with grip insert for draw-down clamping system

Drawings

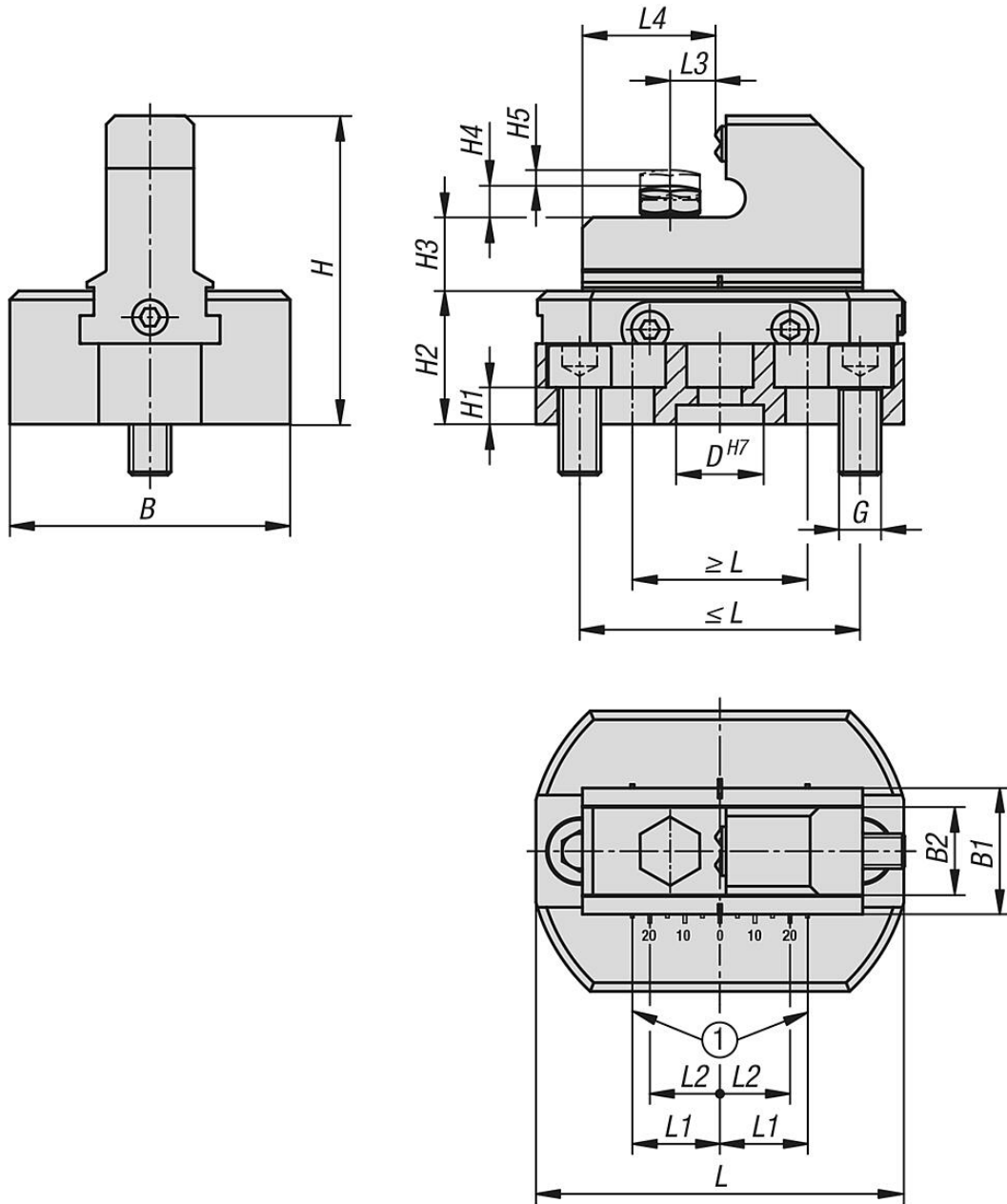

Overview of items

Fixed stop with grip insert for draw-down clamping system

Order No.	Size	B	B1	B2	D	G	H	H1	H2	H3	H4	H5	L	L		L1	L2	L3	L4	F max. kN
														min.	max.					
K2196.121050801	System size 12	80	36	25	25	M12	88	10,5	38	21	8	5	105	50	80	25	22,5	13	38	20
K2196.161301001	System size 16	100	45	30	25	M16	113	13,5	50	25	8	7	130	80	100	33	27,5	18,75	53,75	30

