

Connection friction joints, 40/40 type I

Item description/product images

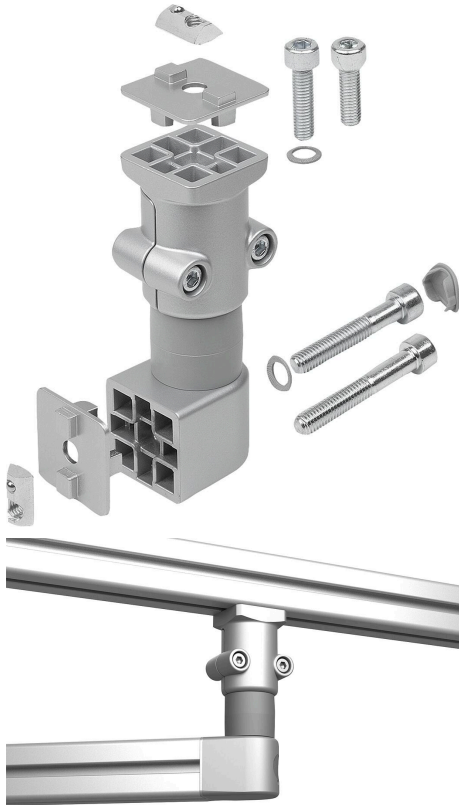

Description

Material:

Housing: die-cast aluminium.
 Inserts and friction shaft: steel.
 Cover ring and end cap: plastic.
 Slot fastening plate: die-cast aluminium.
 Screws, washers and slot keys: steel.

Version:

Housing: painted aluminium tone
 Inserts and friction shaft: bright.
 Cover rings and end caps: similar to RAL 7042.
 Slot fastening plate: painted aluminium tone.
 Screws, washers and slot keys: electro zinc-plated.

Note:

Connection friction joint for constructing individual swivel arms with the aid of aluminium profiles. These connection friction joints are characterised by a fixed friction torque that is available in 6 settings from 0.5 to 15 Nm. Rotates through 360°. Grid pitch 40 mm.

The connection side can be screwed lengthways or crossways onto the profile slot so that the friction axis can be positioned at right angles to the profile. Friction joint side can be attached to the profile lengthways, crossways or on the front. For front mounting, there must be an M8 thread (min. 15 mm deep) in the core hole. When mounting on a flat face, the supplied slot fastening plates can simply be omitted.

The maximum torque M is 45 Nm.

Supplied with:

- 1 Connection friction joint
- 1 End cap
- 1 DIN EN ISO 4762 (DIN 912) screw - M8x45 (for slot key friction joint side)
- 1 DIN EN ISO 4762 (DIN 912) screw - M8x25 (for slot key connection side)
- 1 DIN EN ISO 4762 (DIN 912) screw - M8x50 (for core hole friction joint side)
- 1 DIN EN ISO 4762 (DIN 912) screw - M8x30 (for core hole connection side)
- 2 Washers 8-FSt
- 2 Slot fastening plates
- 2 Slot keys - slot 8 - M8

Connection friction joints, 40/40 type I

Drawings

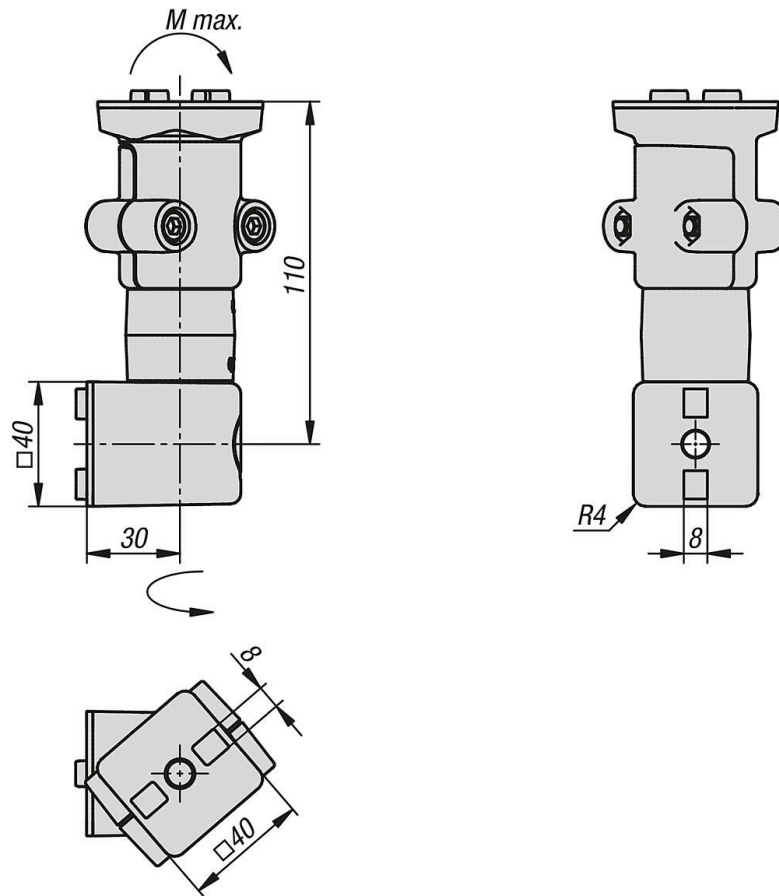

Overview of items

Connection friction joints, 40/40, type I

| Order No. | Type | Slot width | Torque Nm | M Nm |
|-----------|------|------------|-----------|------|
| K2175.005 | I | 8 | 0,5 | 45 |
| K2175.030 | I | 8 | 3 | 45 |
| K2175.060 | I | 8 | 6 | 45 |
| K2175.090 | I | 8 | 9 | 45 |
| K2175.120 | I | 8 | 12 | 45 |
| K2175.150 | I | 8 | 15 | 45 |