

## Rotary lever clamps, pneumatic double-acting

### Item description/product images



### Description

#### Product description:

Rotary lever clamps are highly suited for use in cramped conditions. Due to the compactness of the rotary lever clamps, they can be used in a variety of ways in clamping fixtures with little use of space and thus often enable flexible solutions.

#### Material:

Housing aluminium.  
Piston steel.

#### Version:

Piston hardened.

#### Note:

By the rotary lever clamps, the clamping lever is connected to the piston rod. The air supply for the rotary lever clamps is via drilled channels.

The clamping lever moves towards the workpiece with a linear stroke and clamps it. When releasing, the clamping lever retracts so far that the workpiece can be removed vertically. The single stroke of a rotary lever clamp depends on the clamping lever selection.

The clamping elements must be checked regularly for dirt and cleaned if necessary. When selecting the installation position, it must be ensured that no swarf nests can form in the swivel area of the lever of the rotary lever clamp.

The flange surface of the rotary lever clamp should be adapted to the height of the workpiece during installation and a horizontal positioning of the clamping point should be available.

By positioning the rotary lever clamp correctly, workpiece tolerances can be optimally compensated for despite the short clamping lever.

High forces can be generated with the rotary lever clamps. It must be ensured that the workpieces and clamping fixtures are designed for these loads.

Rotary lever clamps can be fitted with individual tension levers. The clamping force of a rotary lever clamp is dependent on the lever length.

The tension lever for the rotary lever clamp is not supplied.

Follow safety instructions.

#### Type of operation:

Drilled channels.

#### Technical data:

Max. operating pressure: 6 bar.

#### Assembly:

See mounting contour.

#### Advantages:

- No lateral forces during clamping.
- Low mounting dimensions.
- Wide selection of levers.
- Collision-free accessibility to the workpiece.
- Lineless pressure supply.

## Rotary lever clamps, pneumatic double-acting

### Item description/product images

---

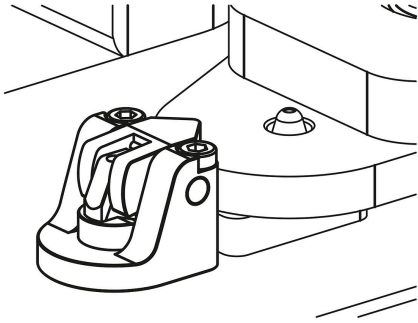
**On request:**

Larger piston diameters, longer strokes and with position control.

**Supplied with:**

Supplied with 4 DIN EN ISO 4762 cap screws, grade 8.8.

**Accessory:**

Tension levers for rotary lever clamps K1857.

**Drawing reference:**

- 1) Tension lever length (see K1857)
- 2) Travel (see K1857)
- 3) See accessories
- 4) Mounting contour
- 5) Rounded edges
- 6) Loosen
- 7) Clamping

Drawings

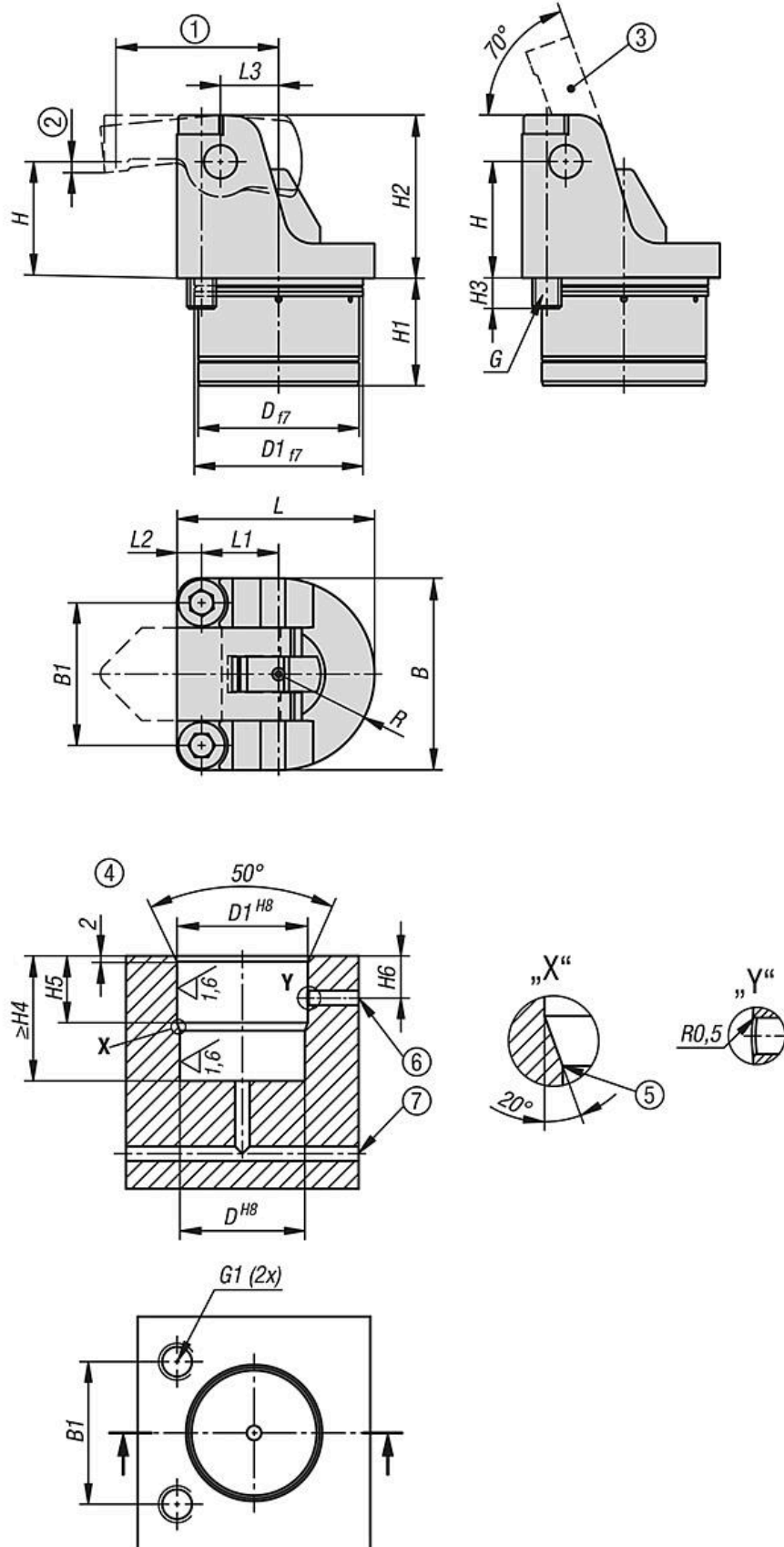

# Rotary lever clamps, pneumatic double-acting

## Drawings

Calculating the effective clamping force with pneumatic rotary lever clamps:

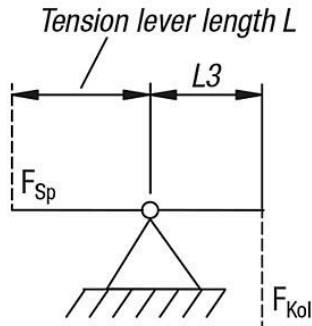

Effective clamping force  $F_{Sp}$  is dependent on piston force  $F_{Kol}$  and tension lever length  $L$

**Calculation:**

$$\text{Clamping force } F_{Sp} = \frac{F_{Kol} \times L/3}{L}$$

$$\text{Clamping force } F_{Sp} = \frac{1.99 \text{ kN} \times 25 \text{ mm}}{45 \text{ mm}} = 1.11 \text{ kN}$$

**Example:**

- Rotary lever clamp cylinder size 40
- Operating pressure 6 bar
- Piston force  $F_{Kol}$  at 6 bar = 1.99 kN
- Dimension  $L/3$  acc. to table = 25 mm
- Tension lever length  $L = 45$  mm
- Resulting effective clamping force  $F_{Sp} = 1.11$  kN

## Overview of items

### Rotary lever clamps, pneumatic, double-acting

Order No.	Piston Ø	Connection type	B	B1	D	D1	G	G1	H	H1	H2	H3
K1870.121304	12	drilled channels	27	19,5	20	21	M4x25	M4x8	15	22	21	7
K1870.161304	16	drilled channels	34	25	27	28	M5x35	M5x11	20	24	28	10,5
K1870.201304	20	drilled channels	40	30	34	35	M6x40	M6x10	25	27,5	35	9
K1870.251304	25	drilled channels	52	38,5	43	44	M8x50	M8x12	31,25	32	43,75	11,5
K1870.321304	32	drilled channels	66	49	57	58	M10x65	M10x16	40	37	56	15,5
K1870.401304	40	drilled channels	78	59	71	72	M12x80	M12x18	50	46	70	17,5

Order No.	Piston Ø	H4	H5	H6	L	L1	L2	L3	R	Piston force at 6 bar (kN)	Effective piston area (cm <sup>2</sup> )
K1870.121304	12	22,5	12	9,5	27	9,75	3,75	7,5	13,5	0,14	2,27
K1870.161304	16	24,5	13	10	35	13,5	4,5	10	17	0,27	4,52
K1870.201304	20	28	15	11	41,5	16,5	5	12,5	20	0,42	7,06
K1870.251304	25	33	19	13	53,5	20,75	6,75	15,63	26	0,68	11,34
K1870.321304	32	38	21	14,5	68	26,5	8,5	20	33	1,27	21,23
K1870.401304	40	47	28	18,5	82	33,5	9,5	25	39	1,99	33,18