

Swing clamps, hydraulic double / single-acting with spring return

Item description/product images

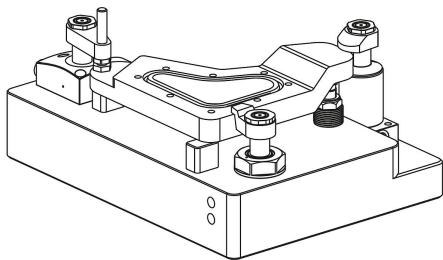

Description

Product description:

Swing clamps are designed for clamping fixtures where the clamping points must be clear during workpiece removal or placement. These swing clamps operate as single-acting or double-acting traction cylinders. There is a choice of three housing types for the swing clamps as well as various actuation methods. The clamping movement is initiated by a combined swivel and stroke motion. The actual clamping travel then occurs with a linear movement. A wide range of variants with a left or right swivel angle of 90° are available. The swing clamps are very durable because they have a metal wiper which protects against swarf. In addition, an overload protection protects the swing mechanism from damage if the swing process is blocked.

Material:

Housing and piston steel.
Seal NBR

Version:

Housing black oxidised.
Piston hardened.

Note:

If the permissible volume flow on the swing clamp could be exceeded, an intermediate throttle check valve must be installed.

The permissible operating pressure of the swing clamps depends on the clamping arm length.

The clamping arms must be restrained when being mounted so that the ball guide of the swing clamps is not damaged.

Depending on the vent connection, the sinter filter of the single-acting swing clamps must be replaced by a screw plug.

The clamping arm of the swing clamp is not supplied.

Follow safety instructions.

Type of operation:

- Thread connection.
- O-ring flange connection.
- Drilled channels.

Technical data:

Max. operating pressure: 500 bar.

Assembly:

See mounting contour.

Advantages:

- Integrated metal wiper.
- Integrated overload protection.
- Collision-free accessibility to the workpiece.
- Many types.
- Pressure supplied over diverse connection possibilities.

On request:

Swing clamps, hydraulic double / single-acting with spring return

Item description/product images

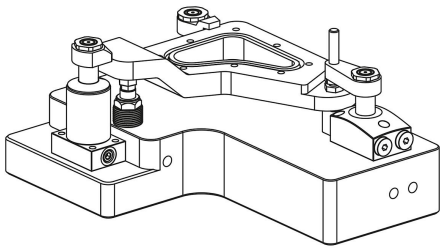

Larger piston diameters and longer strokes, other swivel angles and clamping arms, various clamping arm mounts, with position control.

Supplied with:

Supplied with 1 screw or nut for mounting the clamping arm.

Accessory:

Clamping arm for swing clamp K1865.

Drawing reference:

- Form A: Flange top
- Form B: Flange under
- Form C: Screw-on thread

- 1) Mounting contour
- 2) See accessories
- 3) By the single-acting cylinders, the port is equipped with a built-in sinter filter.
- 4) Left swivel
- 5) Right swivel
- 6) clamp
- 7) release or vent by single acting cylinders

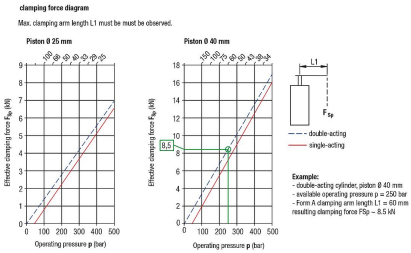

Drawings

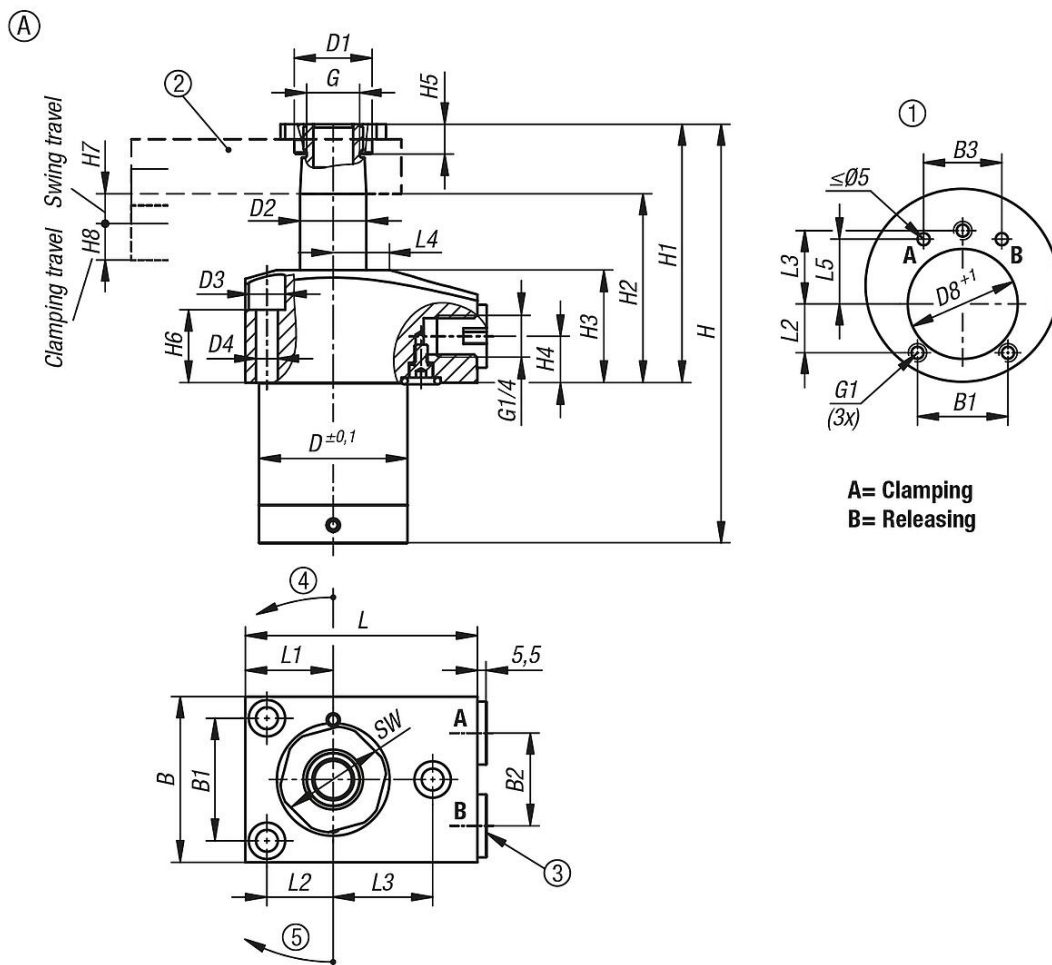

A= Clamping
B= Releasing

Swing clamps, hydraulic double / single-acting with spring return

Drawings

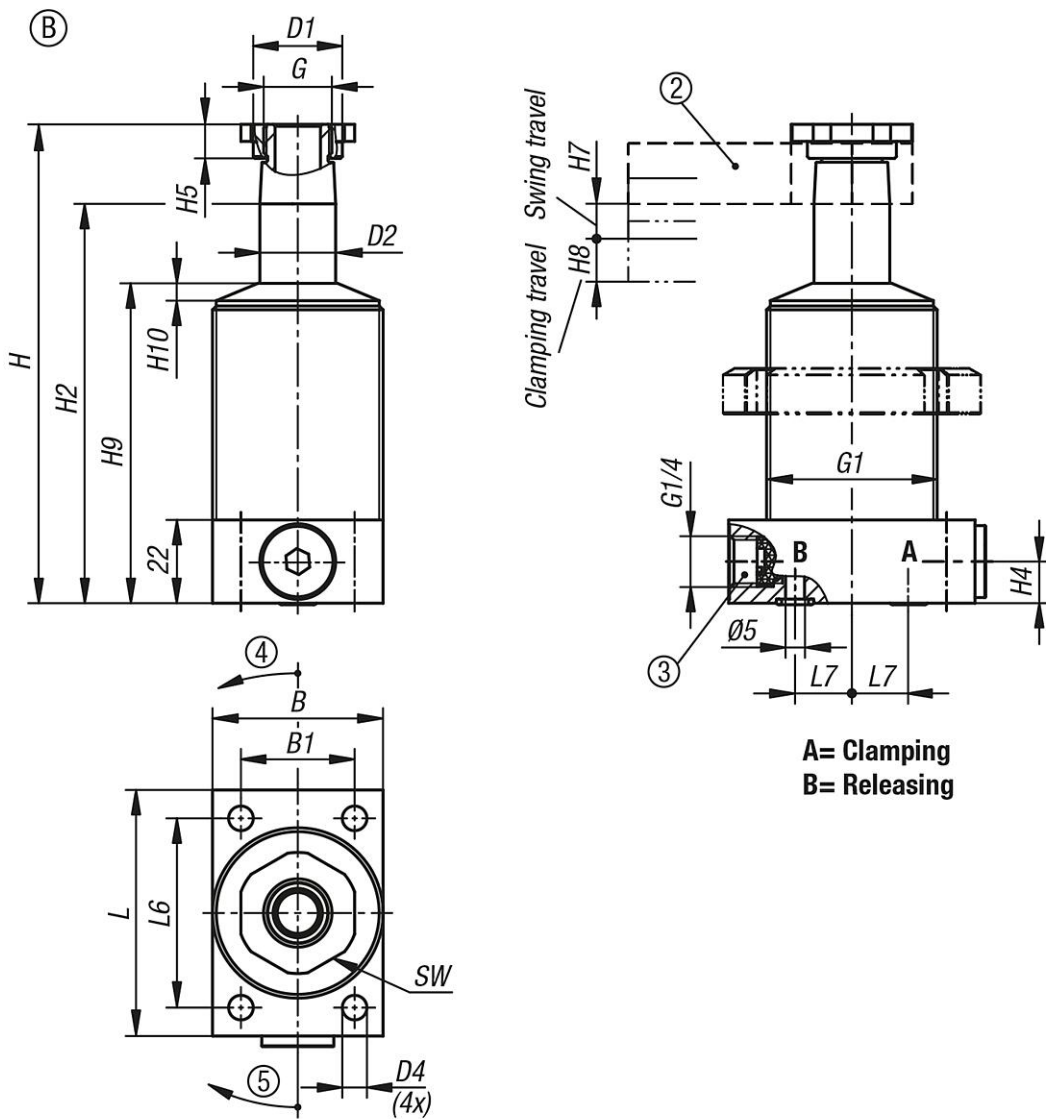

Swing clamps, hydraulic double / single-acting with spring return

Drawings

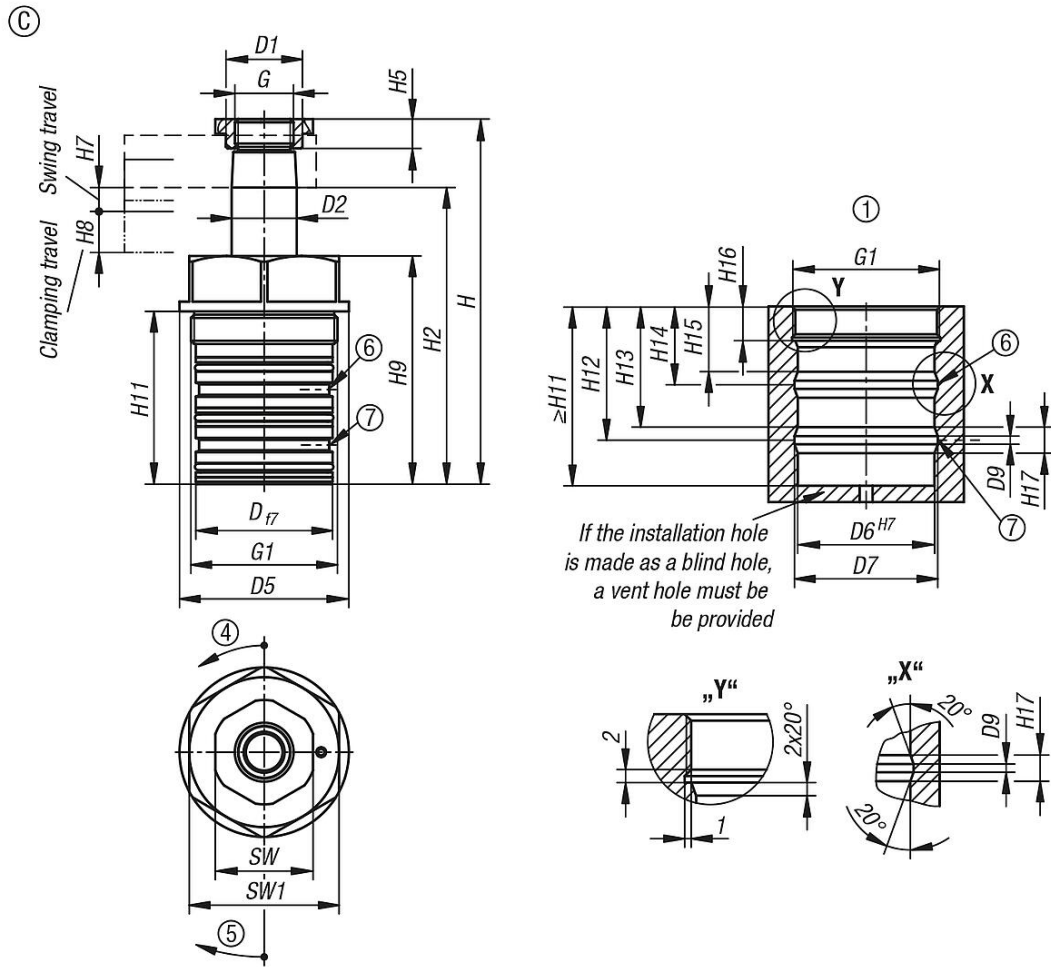

Overview of items

Swing clamps, hydraulic, double / single-acting with spring return

Order No.	Form	Form definition	Connection type	Swivel direction	Piston Ø	travel	B	B1	B2	B3	D	D1	D2	D3	D4	D5	D6	D7	D8	D9
K1864.25101404190211	A	double-acting	Thread and O-ring connection	left	25	10	50	37	28	32	44,8	23,5	20	11	6,6	-	-	-	45	-
K1864.25101404190111	A	double-acting	Thread and O-ring connection	ght	25	10	50	37	28	32	44,8	23,5	20	11	6,6	-	-	-	45	-
K1864.25251404190211	A	double-acting	Thread and O-ring connection	left	25	25	50	37	28	32	44,8	23,5	20	11	6,6	-	-	-	45	-
K1864.25251404190111	A	double-acting	Thread and O-ring connection	ght	25	25	50	37	28	32	44,8	23,5	20	11	6,6	-	-	-	45	-
K1864.40131404190211	A	double-acting	Thread and O-ring connection	left	40	13	63	48	41	46	59,8	33,5	32	15	9	-	-	-	60	-
K1864.40131404190111	A	double-acting	Thread and O-ring connection	ght	40	13	63	48	41	46	59,8	33,5	32	15	9	-	-	-	60	-
K1864.40251404190111	A	double-acting	Thread and O-ring connection	ght	40	25	63	48	41	46	59,8	33,5	32	15	9	-	-	-	60	-
K1864.40251404190211	A	double-acting	Thread and O-ring connection	left	40	25	63	48	41	46	59,8	33,5	32	15	9	-	-	-	60	-
K1864.25102404190111	A	single-acting	Thread and O-ring connection	ght	25	10	50	37	28	32	44,8	23,5	20	11	6,6	-	-	-	45	-
K1864.25102404190211	A	single-acting	Thread and O-ring connection	left	25	10	50	37	28	32	44,8	23,5	20	11	6,6	-	-	-	45	-
K1864.40132404190111	A	single-acting	Thread and O-ring connection	ght	40	13	63	48	41	46	59,8	33,5	32	15	9	-	-	-	60	-
K1864.40132404190211	A	single-acting	Thread and O-ring connection	left	40	13	63	48	41	46	59,8	33,5	32	15	9	-	-	-	60	-
K1864.25101105190211	B	double-acting	screw connection	left	25	10	45	30	-	-	-	23,5	20	-	6,5	-	-	-	-	-
K1864.25101105190111	B	double-acting	screw connection	ght	25	10	45	30	-	-	-	23,5	20	-	6,5	-	-	-	-	-
K1864.25101205190211	B	double-acting	o-ring flange connection	left	25	10	45	30	-	-	-	23,5	20	-	6,5	-	-	-	-	-
K1864.25101205190111	B	double-acting	o-ring flange connection	ght	25	10	45	30	-	-	-	23,5	20	-	6,5	-	-	-	-	-
K1864.25251105190111	B	double-acting	screw connection	ght	25	25	45	30	-	-	-	23,5	20	-	6,5	-	-	-	-	-
K1864.25251105190211	B	double-acting	screw connection	left	25	25	45	30	-	-	-	23,5	20	-	6,5	-	-	-	-	-
K1864.25251205190111	B	double-acting	o-ring flange connection	ght	25	25	45	30	-	-	-	23,5	20	-	6,5	-	-	-	-	-
K1864.25251205190211	B	double-acting	o-ring flange connection	left	25	25	45	30	-	-	-	23,5	20	-	6,5	-	-	-	-	-

Swing clamps, hydraulic double / single-acting with spring return

Overview of items

Order No.	Form	Form definition	Connection type	Swivel direction	Piston Ø	travel	B	B1	B2	B3	D	D1	D2	D3	D4	D5	D6	D7	D8	D9
K1864.40131105190211	B	double-acting	screw connection	left	40	13	63	44	-	-	-	33,5	32	-	8,5	-	-	-	-	-
K1864.40131105190111	B	double-acting	screw connection	ght	40	13	63	44	-	-	-	33,5	32	-	8,5	-	-	-	-	-
K1864.40131205190111	B	double-acting	o-ring flange connection	ght	40	13	63	44	-	-	-	33,5	32	-	8,5	-	-	-	-	-
K1864.40131205190211	B	double-acting	o-ring flange connection	left	40	13	63	44	-	-	-	33,5	32	-	8,5	-	-	-	-	-
K1864.40251105190111	B	double-acting	screw connection	ght	40	25	63	44	-	-	-	33,5	32	-	8,5	-	-	-	-	-
K1864.40251105190211	B	double-acting	screw connection	left	40	25	63	44	-	-	-	33,5	32	-	8,5	-	-	-	-	-
K1864.40251205190111	B	double-acting	o-ring flange connection	ght	40	25	63	44	-	-	-	33,5	32	-	8,5	-	-	-	-	-
K1864.40251205190211	B	double-acting	o-ring flange connection	left	40	25	63	44	-	-	-	33,5	32	-	8,5	-	-	-	-	-
K1864.25102105190111	B	single-acting	screw connection	ght	25	10	45	30	-	-	-	23,5	20	-	6,5	-	-	-	-	-
K1864.25102105190211	B	single-acting	screw connection	left	25	10	45	30	-	-	-	23,5	20	-	6,5	-	-	-	-	-
K1864.25102205190111	B	single-acting	o-ring flange connection	ght	25	10	45	30	-	-	-	23,5	20	-	6,5	-	-	-	-	-
K1864.25102205190211	B	single-acting	o-ring flange connection	left	25	10	45	30	-	-	-	23,5	20	-	6,5	-	-	-	-	-
K1864.40132105190111	B	single-acting	screw connection	ght	40	13	63	44	-	-	-	33,5	32	-	8,5	-	-	-	-	-
K1864.40132105190211	B	single-acting	screw connection	left	40	13	63	44	-	-	-	33,5	32	-	8,5	-	-	-	-	-
K1864.40132205190111	B	single-acting	o-ring flange connection	ght	40	13	63	44	-	-	-	33,5	32	-	8,5	-	-	-	-	-
K1864.40132205190211	B	single-acting	o-ring flange connection	left	40	13	63	44	-	-	-	33,5	32	-	8,5	-	-	-	-	-
K1864.25101306190111	C	double-acting	drilled channels	ght	25	10	-	-	-	-	42	23,5	20	-	-	52	42	44	-	5
K1864.25101306190211	C	double-acting	drilled channels	left	25	10	-	-	-	-	42	23,5	20	-	-	52	42	44	-	5
K1864.40131306190111	C	double-acting	drilled channels	ght	40	13	-	-	-	-	55	33,5	32	-	-	64	55	57	-	5
K1864.40131306190211	C	double-acting	drilled channels	left	40	13	-	-	-	-	55	33,5	32	-	-	64	55	57	-	5
K1864.25102306190111	C	single-acting	drilled channels	ght	25	10	-	-	-	-	42	23,5	20	-	-	52	42	44	-	5
K1864.25102306190211	C	single-acting	drilled channels	left	25	10	-	-	-	-	42	23,5	20	-	-	52	42	44	-	5
K1864.40132306190111	C	single-acting	drilled channels	ght	40	13	-	-	-	-	55	33,5	32	-	-	64	55	57	-	5
K1864.40132306190211	C	single-acting	drilled channels	left	40	13	-	-	-	-	55	33,5	32	-	-	64	55	57	-	5

Order No.	Form	Piston Ø	G	G1	H	H1	H2	H3	H4	H5	H6	H7	H8	H9	H10	H11	H12	H13	H14	H15	H16	H17
K1864.25101404190211	A	25	M18x1,5	M6	126,5	78	57	34	14	9	18	8	10	-	-	-	-	-	-	-	-	-
K1864.25101404190111	A	25	M18x1,5	M6	126,5	78	57	34	14	9	18	8	10	-	-	-	-	-	-	-	-	-
K1864.25251404190211	A	25	M18x1,5	M6	158,5	94	73	34	14	9	18	10	25	-	-	-	-	-	-	-	-	-
K1864.25251404190111	A	25	M18x1,5	M6	158,5	94	73	34	14	9	18	10	25	-	-	-	-	-	-	-	-	-
K1864.40131404190211	A	40	M28x1,5	M8	147,5	94	66	40	14	10	19	9	13	-	-	-	-	-	-	-	-	-
K1864.40131404190111	A	40	M28x1,5	M8	147,5	94	66	40	14	10	19	9	13	-	-	-	-	-	-	-	-	-
K1864.40251404190111	A	40	M28x1,5	M8	173,5	107	79	40	14	10	19	10	25	-	-	-	-	-	-	-	-	-
K1864.40251404190211	A	40	M28x1,5	M8	173,5	107	79	40	14	10	19	10	25	-	-	-	-	-	-	-	-	-
K1864.25102404190111	A	25	M18x1,5	M6	126,5	78	57	34	14	9	18	8	10	-	-	-	-	-	-	-	-	-
K1864.25102404190211	A	25	M18x1,5	M6	126,5	78	57	34	14	9	18	8	10	-	-	-	-	-	-	-	-	-
K1864.40132404190111	A	40	M28x1,5	M8	147,5	94	66	40	14	10	19	9	13	-	-	-	-	-	-	-	-	-
K1864.40132404190211	A	40	M28x1,5	M8	147,5	94	66	40	14	10	19	9	13	-	-	-	-	-	-	-	-	-
K1864.25101105190211	B	25	M18x1,5	M45x1,5	126,5	-	105,5	-	11	9	-	8	10	84,5	5	-	-	-	-	-	-	-
K1864.25101105190111	B	25	M18x1,5	M45x1,5	126,5	-	105,5	-	11	9	-	8	10	84,5	5	-	-	-	-	-	-	-
K1864.25101205190211	B	25	M18x1,5	M45x1,5	126,5	-	105,5	-	11	9	-	8	10	84,5	5	-	-	-	-	-	-	-
K1864.25101205190111	B	25	M18x1,5	M45x1,5	126,5	-	105,5	-	11	9	-	8	10	84,5	5	-	-	-	-	-	-	-
K1864.25251105190111	B	25	M18x1,5	M45x1,5	158,5	-	137,5	-	11	9	-	10	25	100,5	5	-	-	-	-	-	-	-
K1864.25251105190211	B	25	M18x1,5	M45x1,5	158,5	-	137,5	-	11	9	-	10	25	100,5	5	-	-	-	-	-	-	-
K1864.25251205190111	B	25	M18x1,5	M45x1,5	158,5	-	137,5	-	11	9	-	10	25	100,5	5	-	-	-	-	-	-	-
K1864.25251205190211	B	25	M18x1,5	M45x1,5	158,5	-	137,5	-	11	9	-	10	25	100,5	5	-	-	-	-	-	-	-
K1864.40131105190211	B	40	M28x1,5	M60x1,5	147,5	-	119,5	-	11	10	-	9	13	94,5	6	-	-	-	-	-	-	-
K1864.40131105190111	B	40	M28x1,5	M60x1,5	147,5	-	119,5	-	11	10	-	9	13	94,5	6	-	-	-	-	-	-	-
K1864.40131205190111	B	40	M28x1,5	M60x1,5	147,5	-	119,5	-	11	10	-	9	13	94,5	6	-	-	-	-	-	-	-
K1864.40131205190211	B	40	M28x1,5	M60x1,5	147,5	-	119,5	-	11	10	-	9	13	94,5	6	-	-	-	-	-	-	-
K1864.40251105190111	B	40	M28x1,5	M60x1,5	173,5	-	145,5	-	11	10	-	10	25	107,5	6	-	-	-	-	-	-	-
K1864.40251105190211	B	40	M28x1,5	M60x1,5	173,5	-	145,5	-	11	10	-	10	25	107,5	6	-	-	-	-	-	-	-
K1864.40251205190111	B	40	M28x1,5	M60x1,5	173,5	-	145,5	-	11	10	-	10	25	107,5	6	-	-	-	-	-	-	-
K1864.40251205190211	B	40	M28x1,5	M60x1,5	173,5	-	145,5	-	11	10	-	10	25	107,5	6	-	-	-	-	-	-	-
K1864.25102105190111	B	25	M18x1,5	M45x1,5	126,5	-	105,5	-	11	9	-	8	10	84,5	5	-	-	-	-	-	-	-
K1864.25102105190211	B	25	M18x1,5	M45x1,5	126,5	-	105,5	-	11	9	-	8	10	84,5	5	-	-	-	-	-	-	-
K1864.25102205190111	B	25	M18x1,5	M45x1,5	126,5	-	105,5	-	11	9	-	8	10	84,5	5	-	-	-	-	-	-	-
K1864.25102205190211	B	25	M18x1,5	M45x1,5	126,5	-	105,5	-	11	9	-	8	10	84,5	5	-	-	-	-	-	-	-
K1864.40132105190111	B	40	M28x1,5	M60x1,5	147,5	-	119,5	-	11	10	-	9	13	94,5	6	-	-	-	-	-	-	-
K1864.40132105190211	B	40	M28x1,5	M60x1,5	147,5	-	119,5	-	11	10	-	9	13	94,5	6	-	-	-	-	-	-	-
K1864.40132205190111	B	40	M28x1,5	M60x1,5	147,5	-	119,5	-	11	10	-	9	13	94,5	6	-	-	-	-	-	-	-
K1864.40132205190211	B	40	M28x1,5	M60x1,5	147,5	-	119,5	-	11	10	-	9	13	94,5	6	-	-	-	-	-	-	-

Swing clamps, hydraulic double / single-acting with spring return

Overview of items

Order No.	Form	Piston Ø	G	G1	H	H1	H2	H3	H4	H5	H6	H7	H8	H9	H10	H11	H12	H13	H14	H15	H16	H17
K1864.25101306190111	C	25	M18x1,5	M45x1,5	112	-	91	-	-	9	-	8	10	70	-	53	41	37	24	20	10,5	8
K1864.25101306190211	C	25	M18x1,5	M45x1,5	112	-	91	-	-	9	-	8	10	70	-	53	41	37	24	20	10,5	8
K1864.40131306190111	C	40	M28x1,5	M60x1,5	152	-	124	-	-	10	-	9	13	99	-	66	46,5	41,5	29	24	12,5	10
K1864.40131306190211	C	40	M28x1,5	M60x1,5	152	-	124	-	-	10	-	9	13	99	-	66	46,5	41,5	29	24	12,5	10
K1864.25102306190111	C	25	M18x1,5	M45x1,5	112	-	91	-	-	9	-	8	10	70	-	53	41	37	24	20	10,5	8
K1864.25102306190211	C	25	M18x1,5	M45x1,5	112	-	91	-	-	9	-	8	10	70	-	53	41	37	24	20	10,5	8
K1864.40132306190111	C	40	M28x1,5	M60x1,5	152	-	124	-	-	10	-	9	13	99	-	66	46,5	41,5	29	24	12,5	10
K1864.40132306190211	C	40	M28x1,5	M60x1,5	152	-	124	-	-	10	-	9	13	99	-	66	46,5	41,5	29	24	12,5	10

Order No.	Form	Piston Ø	L	L1	L2	L3	L4	L5	L6	L7	SW	SW1	Flow rate max. (cm ³ /s)	Oil requirement / stroke (cm ³)	Oil requirement / return stroke (cm ³)
K1864.25101404190211	A	25	70	26,5	20	30	17	26,5	-	-	27	-	3,2	3,2	8,8
K1864.25101404190111	A	25	70	26,5	20	30	17	26,5	-	-	27	-	3,2	3,2	8,8
K1864.25251404190211	A	25	70	26,5	20	30	17	26,5	-	-	27	-	3,2	6	17
K1864.25251404190111	A	25	70	26,5	20	30	17	26,5	-	-	27	-	3,2	6	17
K1864.40131404190211	A	40	85	34,5	27	38	24	31	-	-	40	-	10	10	27,7
K1864.40131404190111	A	40	85	34,5	27	38	24	31	-	-	40	-	10	10	27,7
K1864.40251404190111	A	40	85	34,5	27	38	24	31	-	-	40	-	10	16	44
K1864.40251404190211	A	40	85	34,5	27	38	24	31	-	-	40	-	10	16	44
K1864.25102404190111	A	25	70	26,5	20	30	17	26,5	-	-	27	-	3,2	3,2	-
K1864.25102404190211	A	25	70	26,5	20	30	17	26,5	-	-	27	-	3,2	3,2	-
K1864.40132404190111	A	40	85	34,5	27	38	24	31	-	-	40	-	10	10	-
K1864.40132404190211	A	40	85	34,5	27	38	24	31	-	-	40	-	10	10	-
K1864.25101105190211	B	25	65	-	-	-	-	-	50	15	27	-	3,2	3,2	8,8
K1864.25101105190111	B	25	65	-	-	-	-	-	50	15	27	-	3,2	3,2	8,8
K1864.25101205190211	B	25	65	-	-	-	-	-	50	15	27	-	3,2	3,2	8,8
K1864.25101205190111	B	25	65	-	-	-	-	-	50	15	27	-	3,2	3,2	8,8
K1864.25251105190111	B	25	65	-	-	-	-	-	50	15	27	-	3,2	6	17
K1864.25251105190211	B	25	65	-	-	-	-	-	50	15	27	-	3,2	6	17
K1864.25251205190111	B	25	65	-	-	-	-	-	50	15	27	-	3,2	6	17
K1864.25251205190211	B	25	65	-	-	-	-	-	50	15	27	-	3,2	6	17
K1864.40131105190211	B	40	85	-	-	-	-	-	65	28	40	-	10	10	27,7
K1864.40131105190111	B	40	85	-	-	-	-	-	65	28	40	-	10	10	27,7
K1864.40131205190111	B	40	85	-	-	-	-	-	65	28	40	-	10	10	27,7
K1864.40131205190211	B	40	85	-	-	-	-	-	65	28	40	-	10	10	27,7
K1864.40251105190111	B	40	85	-	-	-	-	-	65	28	40	-	10	16	44
K1864.40251105190211	B	40	85	-	-	-	-	-	65	28	40	-	10	16	44
K1864.40251205190111	B	40	85	-	-	-	-	-	65	28	40	-	10	16	44
K1864.40251205190211	B	40	85	-	-	-	-	-	65	28	40	-	10	16	44
K1864.25102105190111	B	25	65	-	-	-	-	-	50	15	27	-	3,2	3,2	-
K1864.25102105190211	B	25	65	-	-	-	-	-	50	15	27	-	3,2	3,2	-
K1864.25102205190111	B	25	65	-	-	-	-	-	50	15	27	-	3,2	3,2	-
K1864.25102205190211	B	25	65	-	-	-	-	-	50	15	27	-	3,2	3,2	-
K1864.40132105190111	B	40	85	-	-	-	-	-	65	28	40	-	10	10	-
K1864.40132105190211	B	40	85	-	-	-	-	-	65	28	40	-	10	10	-
K1864.40132205190111	B	40	85	-	-	-	-	-	65	28	40	-	10	10	-
K1864.40132205190211	B	40	85	-	-	-	-	-	65	28	40	-	10	10	-
K1864.25101306190111	C	25	-	-	-	-	-	-	-	-	27	46	3,2	3,2	8,8
K1864.25101306190211	C	25	-	-	-	-	-	-	-	-	27	46	3,2	3,2	8,8
K1864.40131306190111	C	40	-	-	-	-	-	-	-	-	40	55	10	10	27,7
K1864.40131306190211	C	40	-	-	-	-	-	-	-	-	40	55	10	10	27,7
K1864.25102306190111	C	25	-	-	-	-	-	-	-	-	27	46	3,2	3,2	-
K1864.25102306190211	C	25	-	-	-	-	-	-	-	-	27	46	3,2	3,2	-
K1864.40132306190111	C	40	-	-	-	-	-	-	-	-	40	55	10	10	-
K1864.40132306190211	C	40	-	-	-	-	-	-	-	-	40	55	10	10	-