

# Indexing plungers, steel with plastic twist knob and tapered indexing pin

## Item description/product images

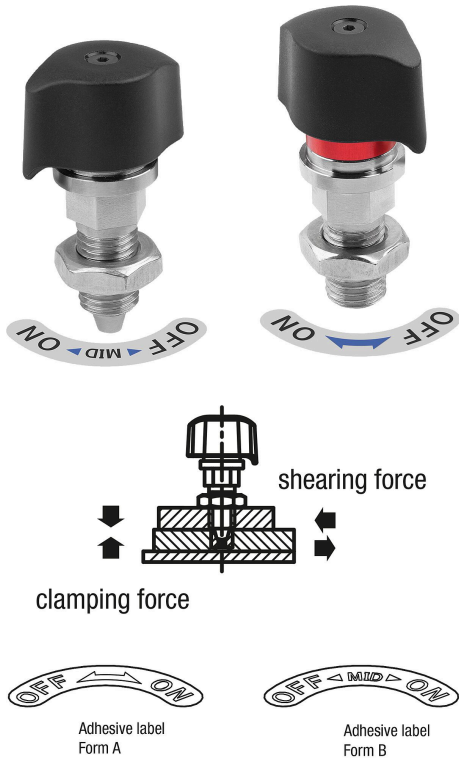

## Description

### Product description:

Indexing plungers are used where any change in locking position due to lateral forces should be prevented.

If the locked mark is visible, the pin is either completely retracted or only partly in the indexed position.

### Material:

Housing and pin steel.

Locked mark and label aluminum.

Twist knob thermoplastic PA (polyamide)

### Version:

Housing and pin nickel plated.

Locked mark anodised, red.

Twist knob fiberglass reinforced, black.

### Type of operation:

#### Style A:

Check that the twist knob is in the "OFF" position and that the pin is retracted.

Slide the plate with the bushing under the indexing plunger.

To clamp, turn the twist knob to the "ON" position.

When fully clamped, an audible click will be heard.

Caution: Do not loosen the clamping of the indexing plunger when the pin is under an axial load. Due to the conical shape, the pin may not retract.

#### Style B:

With the twist knob in the "OFF" position, slide the plate with the bushing towards the indexing plunger until the spring locks the pin into the bushing.

The twist knob will move automatically to the "MID" position.

For complete clamping, turn the twist knob from the "MID" position to the "ON" position until a click signal is heard.

### Supplied with:

A locknut and a 0.2 mm thick label are supplied.

### Accessory:

Bush K1835.

### Drawing reference:

- 1) Installation without bushing K1835
- 2) Mounting plate
- 3) Base plate
- 4) Locked mark
- 5) ON position
- 6) OFF position
- 7) Label

## Indexing plungers, steel with plastic twist knob and tapered indexing pin

### Drawings

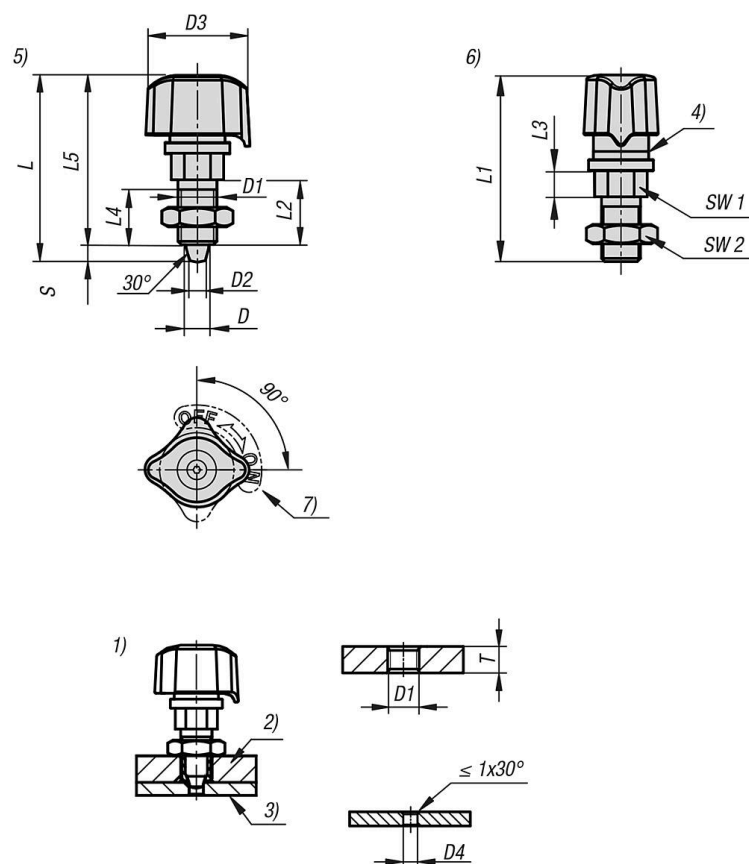

### Overview of items

#### Indexing plungers steel, with twist knob and tapered indexing pin

Order No.	Form	Form definition	D	D1	D2	D3	D4	T	L	L1	L2	L3	L4	L5
K1833.0005	A	-	5	M10x1	3,3	26	3,7-4,6	8-10	48,2	48	17	7	15	44
K1833.0007	A	-	7	M12x1,5	4,9	32	5,3-6,6	9-11	57	58	20	8	17	52
K1833.0107	B	-	7	M12x1,5	4,9	32	5,3-6,6	9-11	57	58	20	8	17	52

Order No.	Form	Travel S	SW1	SW2	Clamping force N	F= Spring strength (N)	Temperature resistance	Shearing force kN
K1833.0005	A	4,2	13	17	140	-	80 °C	0,9
K1833.0007	A	5	14	19	170	-	80 °C	1,3
K1833.0107	B	5	14	19	170	9	80 °C	1,3