

Multi-clamping system single-sided wedge clamps fixed jaw ES

Item description/product images

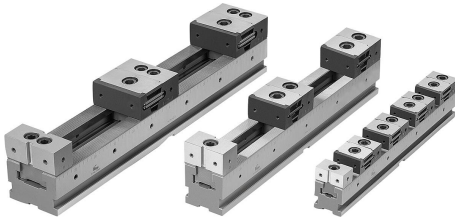

Maximum workpiece sizes for the types wedge clamp with fixed jaw

Clamping rails	1 pcs.			2 pcs.		
	B=50	B=72	B=100	B=50	B=72	B=100
L=300	203	-	-	68	-	-
L=400	302	273	253	118	92	74
L=500	404	373	353	169	142	124
L=600	503	473	453	219	192	174
L=700	602	573	553	269	242	224

Clamping rails	3 pcs.			4 pcs.		
	B=50	B=72	B=100	B=50	B=72	B=100
L=300	23	-	-	-	-	-
L=400	56	32	14	26	-	-
L=500	90	65	48	51	27	9
L=600	123	99	81	76	52	34
L=700	156	132	114	101	77	59

Clamping rails	5 pcs.			6 pcs.		
	B=50	B=72	B=100	B=50	B=72	B=100
L=300	-	-	-	-	-	-
L=400	7	-	-	-	-	-
L=500	27	-	-	12	-	-
L=600	47	24	6	29	5	-
L=700	67	44	26	45	22	-

Clamping rails	7 pcs.			8 pcs.		
	B=50	B=72	B=100	B=50	B=72	B=100
L=300	-	-	-	-	-	-
L=400	-	-	-	-	-	-
L=500	-	-	-	-	-	-
L=600	15	-	-	5	-	-
L=700	29	6	-	17	7	-



Combination of clamping rails for multi-clamping system K1746.
Wedge clamp with fixed jaw for multi-clamping system K1749 and 1x fixed jaw ES for multi-clamping system K1750.

Description

Material:

Clamping rail and fixed jaw tool steel.

Wedge clamp mild steel.

Version:

Clamping rail and fixed jaw hardened and ground (HRC 55 ±2).

Wedge clamp hardened, phosphated.

Note:

The multi-clamping system can be fastened using various interfaces.

1. Lateral clamping edge for clamping claw set. Clamping claws can be fastened at any position.
2. Holes for DIN cap screws.
3. Ø25 mm locating holes for conventional zero-point clamping systems with 200 mm spacing.
4. Ø16 mm locating holes for zero-point clamping systems with 96 mm spacing.
5. Three 18H7 alignment slots for crosswise and lengthwise alignment on T- slot tables.
6. Ø12F7 and Ø16F7 reamed holes for 40 and 50 mm grid systems.

Three different versions are available:

- Multi-clamping system double-sided wedge clamp with OS fixed jaw / K1828.
- Multi-clamping system double-sided wedge clamp with DS fixed jaw / K1829.
- Multi-clamping system single-sided wedge clamp with OS fixed jaw / K1830.

Technical data:

System width 50

Maximum clamping force: 15 kN

Maximum tightening torque: 55 Nm

System width 72

Maximum clamping force: 25 kN

Maximum tightening torque: 60 Nm

System width 100

Maximum clamping force: 35 kN

Maximum tightening torque: 85 Nm

Application:

A number of multi-clamping systems with different lengths can be mounted one behind the other or beside each other. The precision toothing enables highly precise positioning of the fixed jaws. Due to the lateral graduations on the clamping rails, each position of the fixed jaws can be documented and reset identically. Stops can be mounted in the tapped holes on the side.

Turning the clamping screw moves the clamping segments outwards and press the workpieces against the fixed jaw.

Advantages:

Universal and flexible.

For small and large batch sizes.

Large components can also be clamped next to each other on several multiple clamping systems.

Multi-clamping system single-sided wedge clamps fixed jaw ES

Item description/product images

Supplied with:

1x clamping rail

The number of wedge clamps and fixed jaws is dependent on the system size (see table).

Accessory:

Clamping pin K0967.

Cap screws K0869.

Shoulder screws K0815.12045 / K0815.16055.

Seating ledges K1752.

Attachment jaws with machining allowance K1753.

Attachment jaws with prism K1754.

Workpiece stop K1755.

Spacer K1756.

Clamping claw set K1757.

T-slot nut K1758.

T-slot key K0954.

Multi-clamping system single-sided wedge clamps fixed jaw ES

Drawings

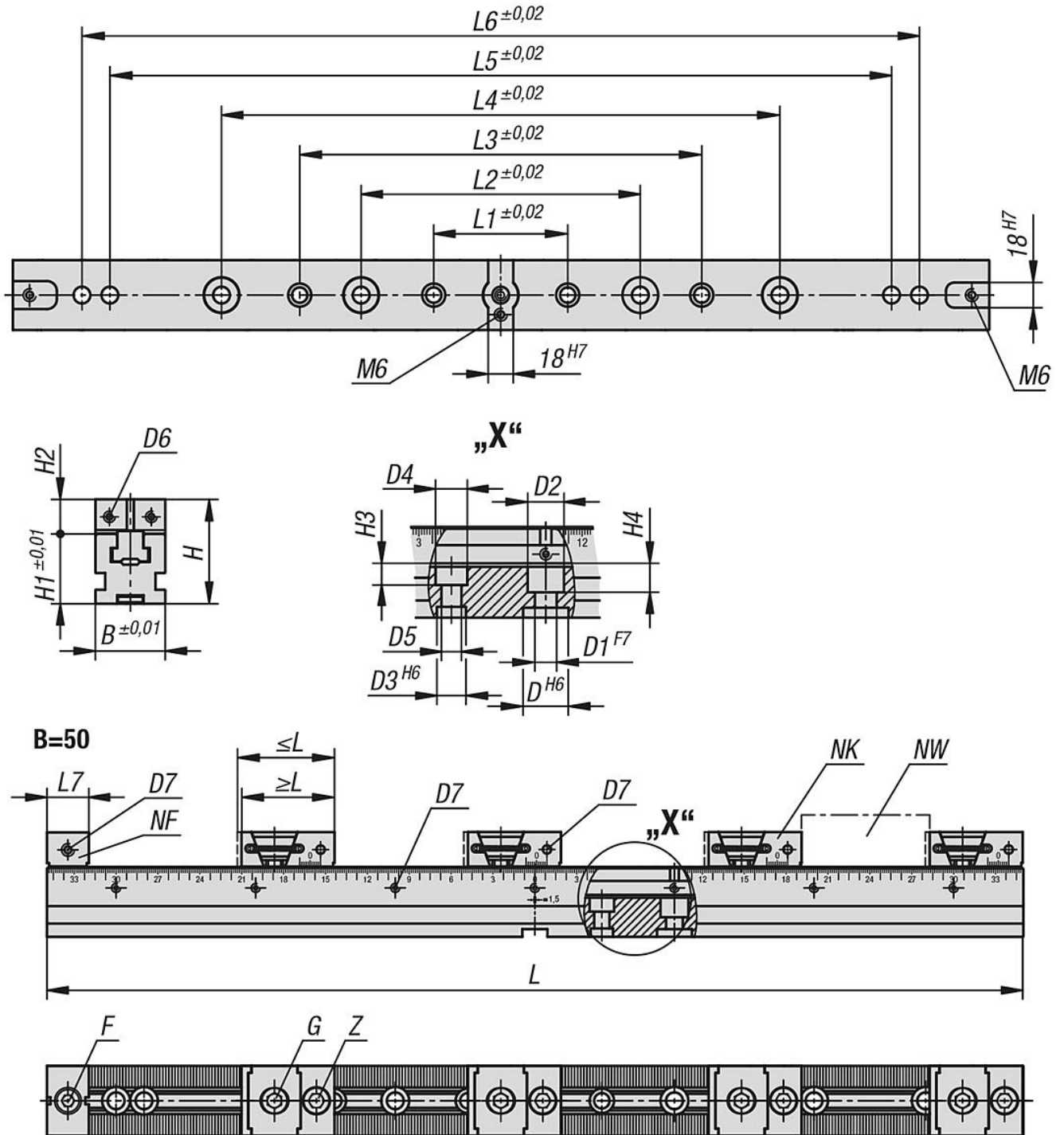

Multi-clamping system single-sided wedge clamps fixed jaw ES

Drawings

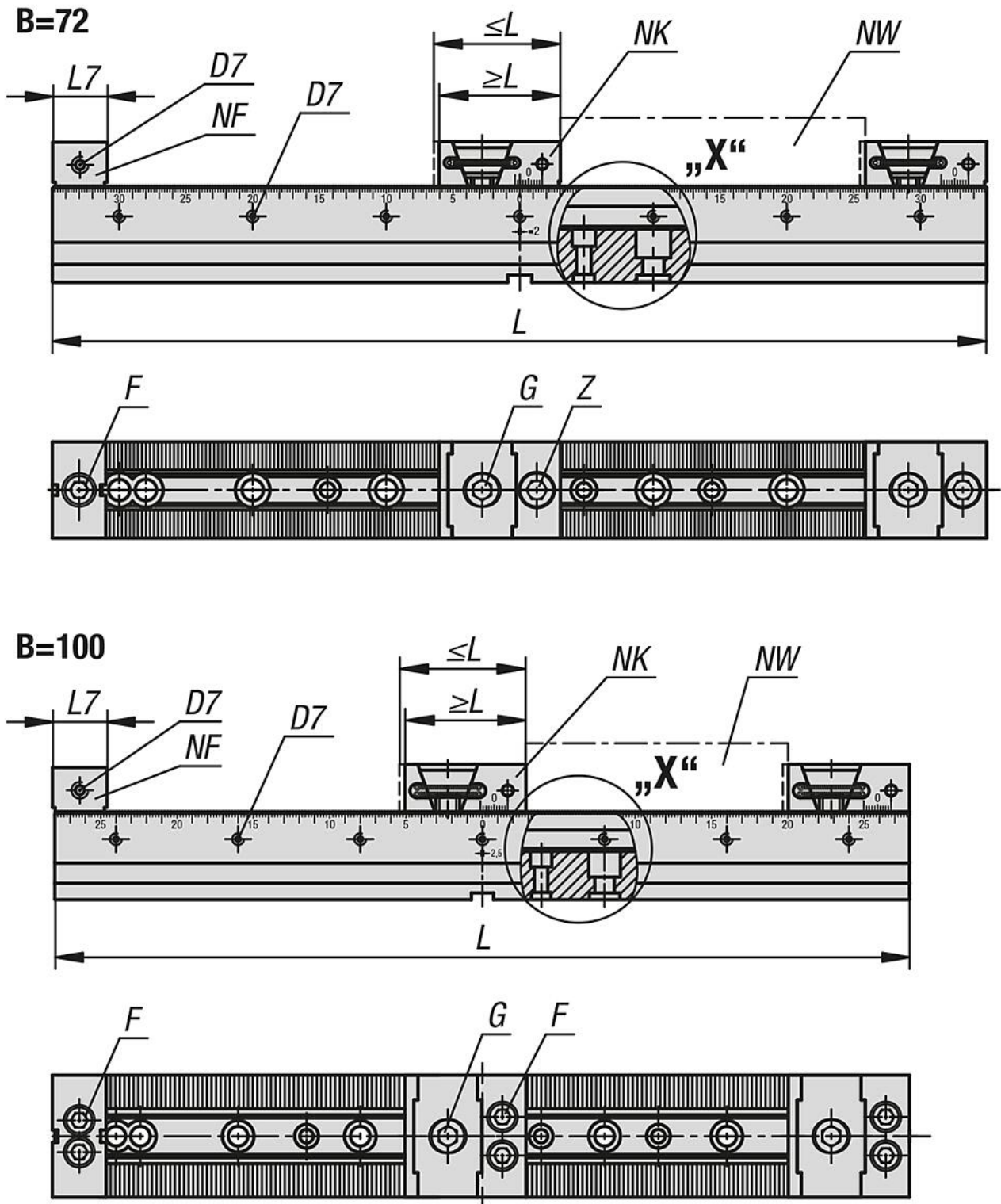

Overview of items

Multi-clamping system single-sided wedge clamps fixed jaw ES

Multi-clamping system single-sided wedge clamps fixed jaw ES

Overview of items

Order No.	B	Version 1	L	H	L min.	L max.	L1	L2	L3	L4	L5	L6	L7	Clamping force max. kN	Tightening torque max. Nm
K1830.05040001	50	smooth	400	75	64	70	96	200	288	300	-	-	30	15	55
K1830.05050001	50	smooth	500	75	64	70	96	200	288	400	-	-	30	15	55
K1830.05060001	50	smooth	600	75	64	70	96	200	288	400	500	-	30	15	55
K1830.05070001	50	smooth	700	75	64	70	96	200	288	400	560	600	30	15	55
K1830.05040002	50	serrated	400	75	64	70	96	200	288	300	-	-	30	15	55
K1830.05050002	50	serrated	500	75	64	70	96	200	288	400	-	-	30	15	55
K1830.05060002	50	serrated	600	75	64	70	96	200	288	400	500	-	30	15	55
K1830.05070002	50	serrated	700	75	64	70	96	200	288	400	560	600	30	15	55
K1830.07240001	72	smooth	400	112	86	93	96	200	288	300	-	-	40	25	60
K1830.07250001	72	smooth	500	112	86	93	96	200	288	400	-	-	40	25	60
K1830.07260001	72	smooth	600	112	86	93	96	200	288	400	500	-	40	25	60
K1830.07270001	72	smooth	700	112	86	93	96	200	288	400	560	600	40	25	60
K1830.07240002	72	serrated	400	112	86	93	96	200	288	300	-	-	40	25	60
K1830.07250002	72	serrated	500	112	86	93	96	200	288	400	-	-	40	25	60
K1830.07260002	72	serrated	600	112	86	93	96	200	288	400	500	-	40	25	60
K1830.07270002	72	serrated	700	112	86	93	96	200	288	400	560	600	40	25	60
K1830.10040001	100	smooth	400	114,6	101,5	111,5	96	200	288	300	-	-	70	35	85
K1830.10050001	100	smooth	500	114,6	101,5	111,5	96	200	288	400	-	-	70	35	85
K1830.10060001	100	smooth	600	114,6	101,5	111,5	96	200	288	400	500	-	70	35	85
K1830.10070001	100	smooth	700	114,6	101,5	111,5	96	200	288	400	560	600	70	35	85
K1830.10040002	100	serrated	400	114,6	101,5	111,5	96	200	288	300	-	-	70	35	85
K1830.10050002	100	serrated	500	114,6	101,5	111,5	96	200	288	400	-	-	70	35	85
K1830.10060002	100	serrated	600	114,6	101,5	111,5	96	200	288	400	500	-	70	35	85
K1830.10070002	100	serrated	700	114,6	101,5	111,5	96	200	288	400	560	600	70	35	85

Order No.	B	Version 1	L	D	D1	D2	D3	D4	D5	D6	D7	H1	H2	H3	H4	Clamping force max. kN	Tightening torque max. Nm
K1830.05040001	50	smooth	400	25	12	20	16	17,5	11	M5	M6	50	25	12	16	15	55
K1830.05050001	50	smooth	500	25	12	20	16	17,5	11	M5	M6	50	25	12	16	15	55
K1830.05060001	50	smooth	600	25	12	20	16	17,5	11	M5	M6	50	25	12	16	15	55
K1830.05070001	50	smooth	700	25	12	20	16	17,5	11	M5	M6	50	25	12	16	15	55
K1830.05040002	50	serrated	400	25	12	20	16	17,5	11	M5	M6	50	25	12	16	15	55
K1830.05050002	50	serrated	500	25	12	20	16	17,5	11	M5	M6	50	25	12	16	15	55
K1830.05060002	50	serrated	600	25	12	20	16	17,5	11	M5	M6	50	25	12	16	15	55
K1830.05070002	50	serrated	700	25	12	20	16	17,5	11	M5	M6	50	25	12	16	15	55
K1830.07240001	72	smooth	400	25	16	26	16	17,5	11	M6	M6	72	40	15	23,5	25	60
K1830.07250001	72	smooth	500	25	16	26	16	17,5	11	M6	M6	72	40	15	23,5	25	60
K1830.07260001	72	smooth	600	25	16	26	16	17,5	11	M6	M6	72	40	15	23,5	25	60
K1830.07270001	72	smooth	700	25	16	26	16	17,5	11	M6	M6	72	40	15	23,5	25	60
K1830.07240002	72	serrated	400	25	16	26	16	17,5	11	M6	M6	72	40	15	23,5	25	60
K1830.07250002	72	serrated	500	25	16	26	16	17,5	11	M6	M6	72	40	15	23,5	25	60
K1830.07260002	72	serrated	600	25	16	26	16	17,5	11	M6	M6	72	40	15	23,5	25	60
K1830.07270002	72	serrated	700	25	16	26	16	17,5	11	M6	M6	72	40	15	23,5	25	60
K1830.10040001	100	smooth	400	25	16	26	16	17,5	11	M6	M8	72	42,6	15	23,5	35	85
K1830.10050001	100	smooth	500	25	16	26	16	17,5	11	M6	M8	72	42,6	15	23,5	35	85
K1830.10060001	100	smooth	600	25	16	26	16	17,5	11	M6	M8	72	42,6	15	23,5	35	85
K1830.10070001	100	smooth	700	25	16	26	16	17,5	11	M6	M8	72	42,6	15	23,5	35	85
K1830.10040002	100	serrated	400	25	16	26	16	17,5	11	M6	M8	72	42,6	15	23,5	35	85
K1830.10050002	100	serrated	500	25	16	26	16	17,5	11	M6	M8	72	42,6	15	23,5	35	85
K1830.10060002	100	serrated	600	25	16	26	16	17,5	11	M6	M8	72	42,6	15	23,5	35	85
K1830.10070002	100	serrated	700	25	16	26	16	17,5	11	M6	M8	72	42,6	15	23,5	35	85

Order No.	B	Version 1	L	F Socket head screw DIN 912	G cap screw DIN 912	Z cap screw DIN 912	NK = Quantity Wedge clamp	NF = Quantity Fixed jaw	NW = Quantity Workpieces
K1830.05040001	50	smooth	400	M10x30	M12x25	M12x30	4	1	4
K1830.05050001	50	smooth	500	M10x30	M12x25	M12x30	4	1	4
K1830.05060001	50	smooth	600	M10x30	M12x25	M12x30	4	1	4
K1830.05070001	50	smooth	700	M10x30	M12x25	M12x30	4	1	4
K1830.05040002	50	serrated	400	M10x30	M12x25	M12x30	4	1	4

Multi-clamping system single-sided wedge clamps fixed jaw ES

Overview of items

Order No.	B	Version 1	L	F Socket head screw DIN 912	G cap screw DIN 912	Z cap screw DIN 912	NK = Quantity Wedge clamp	NF = Quantity Fixed jaw	NW = Quantity Workpieces
K1830.05050002	50	serrated	500	M10x30	M12x25	M12x30	4	1	4
K1830.05060002	50	serrated	600	M10x30	M12x25	M12x30	4	1	4
K1830.05070002	50	serrated	700	M10x30	M12x25	M12x30	4	1	4
K1830.07240001	72	smooth	400	M14X1,5X50	M16x40	M16X50	2	1	2
K1830.07250001	72	smooth	500	M14X1,5X50	M16x40	M16X50	2	1	2
K1830.07260001	72	smooth	600	M14X1,5X50	M16x40	M16X50	2	1	2
K1830.07270001	72	smooth	700	M14X1,5X50	M16x40	M16X50	2	1	2
K1830.07240002	72	serrated	400	M14X1,5X50	M16x40	M16X50	2	1	2
K1830.07250002	72	serrated	500	M14X1,5X50	M16x40	M16X50	2	1	2
K1830.07260002	72	serrated	600	M14X1,5X50	M16x40	M16X50	2	1	2
K1830.07270002	72	serrated	700	M14X1,5X50	M16x40	M16X50	2	1	2
K1830.10040001	100	smooth	400	M14X1,5X50	M16x40	-	2	1	2
K1830.10050001	100	smooth	500	M14X1,5X50	M16x40	-	2	1	2
K1830.10060001	100	smooth	600	M14X1,5X50	M16x40	-	2	1	2
K1830.10070001	100	smooth	700	M14X1,5X50	M16x40	-	2	1	2
K1830.10040002	100	serrated	400	M14X1,5X50	M16x40	-	2	1	2
K1830.10050002	100	serrated	500	M14X1,5X50	M16x40	-	2	1	2
K1830.10060002	100	serrated	600	M14X1,5X50	M16x40	-	2	1	2
K1830.10070002	100	serrated	700	M14X1,5X50	M16x40	-	2	1	2