

Multi-clamping system double-sided wedge clamps fixed jaw DS

Item description/product images

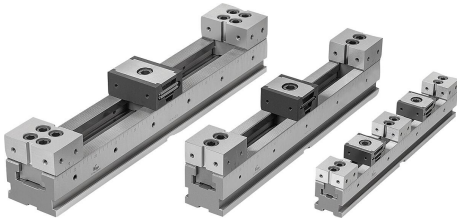

Maximum workpiece sizes for the types double-sided wedge clamp and fixed jaw DS

Clamping rails	1 pcs.			2 pcs.		
	B=50	B=72	B=100	B=50	B=72	B=100
L=300	164	-	-	82	-	-
L=400	263	208	190	131	104	95
L=500	365	308	290	182	154	145
L=600	464	408	390	232	204	195
L=700	563	508	490	281	254	245

Clamping rails	3 pcs.			4 pcs.		
	B=50	B=72	B=100	B=50	B=72	B=100
L=300	18	-	-	18	-	-
L=400	57	26	15	43	20	17
L=500	91	60	48	68	45	36
L=600	124	93	82	93	70	61
L=700	157	126	115	118	95	86

Clamping rails	5 pcs.			6 pcs.		
	B=50	B=72	B=100	B=50	B=72	B=100
L=300	-	-	-	-	-	-
L=400	16	-	-	13	-	-
L=500	36	10	-	30	9	-
L=600	56	30	20	47	25	17
L=700	78	50	40	63	42	33

Clamping rails	7 pcs.			8 pcs.		
	B=50	B=72	B=100	B=50	B=72	B=100
L=300	-	-	-	-	-	-
L=400	-	-	-	-	-	-
L=500	13	-	-	11	-	-
L=600	27	-	-	24	-	-
L=700	41	18	18	36	15	7

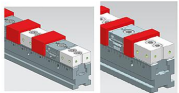

Combination of clamping rails for multi-clamping system K1746.
Wedge clamp K1748 and
Fixed jaw OS for multi-clamping system K1751.

Description

Material:

Clamping rail and fixed jaw tool steel.

Wedge clamp mild steel.

Version:

Clamping rail and fixed jaw hardened and ground (HRC 55 ±2).

Wedge clamp hardened, phosphated.

Note:

The multi-clamping system can be fastened using various interfaces.

1. Lateral clamping edge for clamping claw set. Clamping claws can be fastened at any position.
2. Holes for DIN cap screws.
3. Ø25 mm locating holes for conventional zero-point clamping systems with 200 mm spacing.
4. Ø16 mm locating holes for zero-point clamping systems with 96 mm spacing.
5. Three 18H7 alignment slots for crosswise and lengthwise alignment on T- slot tables.
6. Ø12F7 and Ø16F7 reamed holes for 40 and 50 mm grid systems.

Three different versions are available:

- Multi-clamping system double-sided wedge clamp with OS fixed jaw / K1828.
- Multi-clamping system double-sided wedge clamp with DS fixed jaw / K1829.
- Multi-clamping system single-sided wedge clamp with OS fixed jaw / K1830.

Technical data:

System width 50

Maximum clamping force: 20 kN

Maximum tightening torque: 50 Nm

System width 72

Maximum clamping force: 30 kN

Maximum tightening torque: 65 Nm

System width 100

Maximum clamping force: 40 kN

Maximum tightening torque: 100 Nm

Application:

A number of multi-clamping systems with different lengths can be mounted one behind the other or beside each other. The precision toothing enables highly precise positioning of the fixed jaws. Due to the lateral graduations on the clamping rails, each position of the fixed jaws can be documented and reset identically. Stops can be mounted in the tapped holes on the side.

Turning the clamping screw moves the clamping segments outwards and press the workpieces against the fixed jaw.

Advantages:

Universal and flexible.

For small and large batch sizes.

Large components can also be clamped next to each other on several multiple clamping systems.

Multi-clamping system double-sided wedge clamps fixed jaw DS

Item description/product images

Supplied with:

1x clamping rail

The number of wedge clamps and fixed jaws is dependent on the system size (see table).

Accessory:

Clamping pin K0967.

Cap screws K0869.

Shoulder screws K0815.12045 / K0815.16055.

Seating ledges K1752.

Attachment jaws with machining allowance K1753.

Attachment jaws with prism K1754.

Workpiece stop K1755.

Spacer K1756.

Clamping claw set K1757.

T-slot nut K1758.

T-slot key K0954.

Multi-clamping system double-sided wedge clamps fixed jaw DS

Drawings

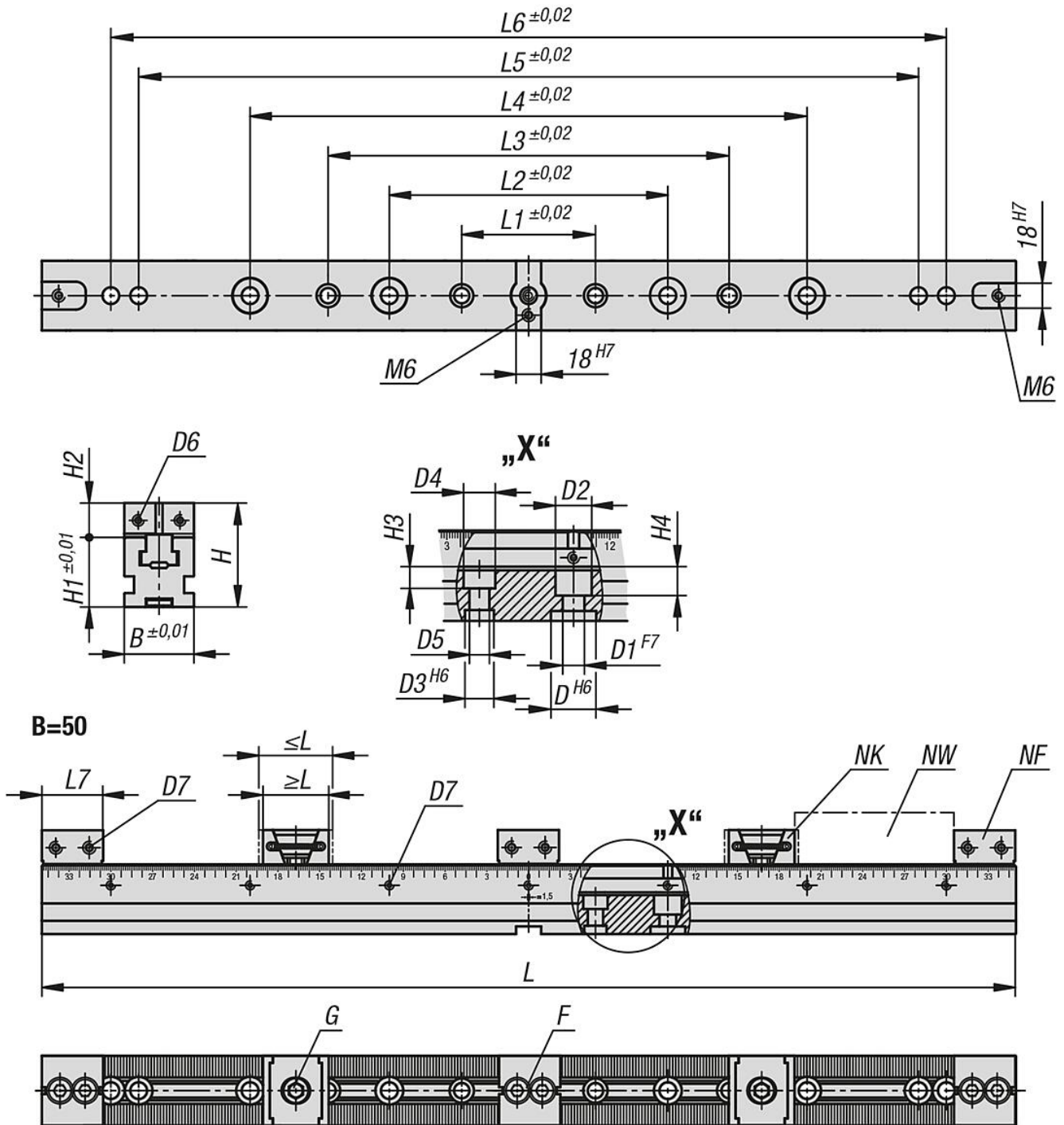

Multi-clamping system double-sided wedge clamps fixed jaw DS

Drawings

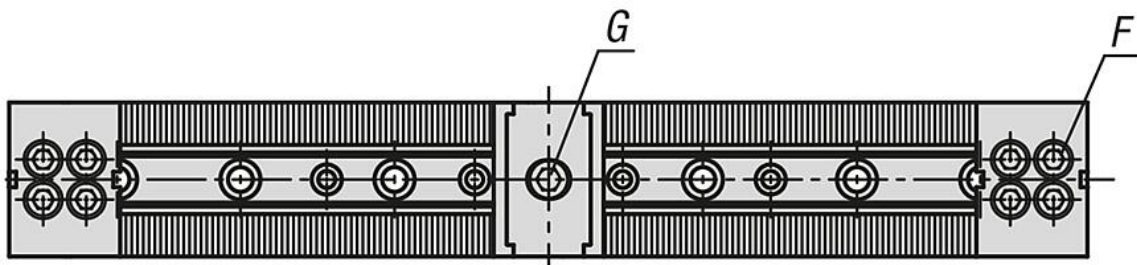
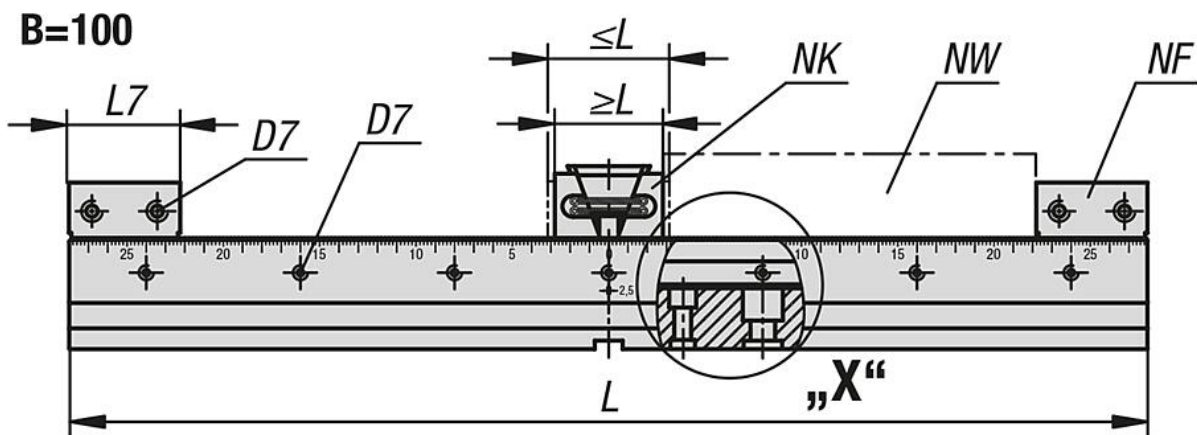
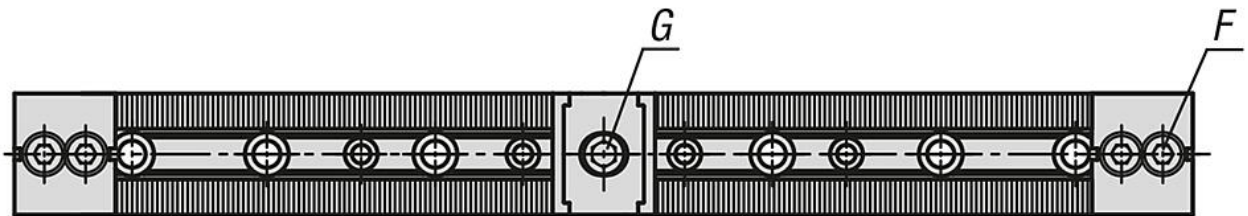
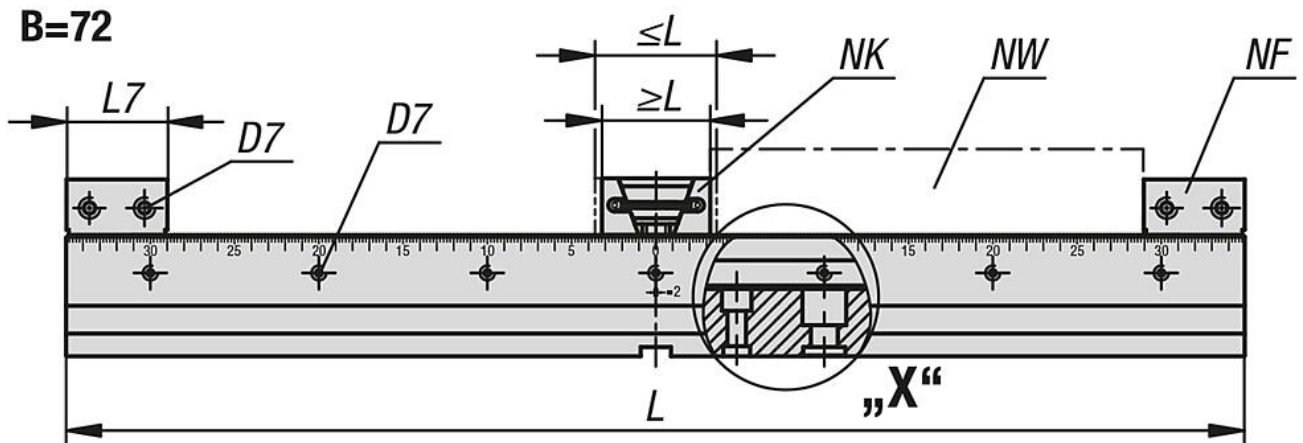

Overview of items

Multi-clamping system double-sided wedge clamps, fixed jaw DS

Multi-clamping system double-sided wedge clamps fixed jaw DS

Overview of items

Order No.	B	Version 1	L	H	L min.	L max.	L1	L2	L3	L4	L5	L6	L7	Clamping force max. kN	Tightening torque max. Nm
K1829.05030001	50	smooth	300	75	44,5	50,5	96	200	-	-	-	-	44	20	50
K1829.05040001	50	smooth	400	75	44,5	50,5	96	200	288	300	-	-	44	20	50
K1829.05050001	50	smooth	500	75	44,5	50,5	96	200	288	400	-	-	44	20	50
K1829.05060001	50	smooth	600	75	44,5	50,5	96	200	288	400	500	-	44	20	50
K1829.05070001	50	smooth	700	75	44,5	50,5	96	200	288	400	560	600	44	20	50
K1829.05030002	50	serrated	300	75	44,5	50,5	96	200	-	-	-	-	44	20	50
K1829.05040002	50	serrated	400	75	44,5	50,5	96	200	288	300	-	-	44	20	50
K1829.05050002	50	serrated	500	75	44,5	50,5	96	200	288	400	-	-	44	20	50
K1829.05060002	50	serrated	600	75	44,5	50,5	96	200	288	400	500	-	44	20	50
K1829.05070002	50	serrated	700	75	44,5	50,5	96	200	288	400	560	600	44	20	50
K1829.07240001	72	smooth	400	112	61	68	96	200	288	300	-	-	65	30	65
K1829.07250001	72	smooth	500	112	61	68	96	200	288	400	-	-	65	30	65
K1829.07260001	72	smooth	600	112	61	68	96	200	288	400	500	-	65	30	65
K1829.07270001	72	smooth	700	112	61	68	96	200	288	400	560	600	65	30	65
K1829.07240002	72	serrated	400	112	61	68	96	200	288	300	-	-	65	30	65
K1829.07250002	72	serrated	500	112	61	68	96	200	288	400	-	-	65	30	65
K1829.07260002	72	serrated	600	112	61	68	96	200	288	400	500	-	65	30	65
K1829.07270002	72	serrated	700	112	61	68	96	200	288	400	560	600	65	30	65
K1829.10040001	100	smooth	400	114,6	71	78	96	200	288	300	-	-	70	40	100
K1829.10050001	100	smooth	500	114,6	71	78	96	200	288	400	-	-	70	40	100
K1829.10060001	100	smooth	600	114,6	71	78	96	200	288	400	500	-	70	40	100
K1829.10070001	100	smooth	700	114,6	71	78	96	200	288	400	560	600	70	40	100
K1829.10040002	100	serrated	400	114,6	71	78	96	200	288	300	-	-	70	40	100
K1829.10050002	100	serrated	500	114,6	71	78	96	200	288	400	-	-	70	40	100
K1829.10060002	100	serrated	600	114,6	71	78	96	200	288	400	500	-	70	40	100
K1829.10070002	100	serrated	700	114,6	71	78	96	200	288	400	560	600	70	40	100

Order No.	B	Version 1	L	D	D1	D2	D3	D4	D5	D6	D7	H1	H2	H3	H4	Clamping force max. kN	Tightening torque max. Nm
K1829.05030001	50	smooth	300	25	12	20	16	17,5	11	M5	M6	50	25	12	16	20	50
K1829.05040001	50	smooth	400	25	12	20	16	17,5	11	M5	M6	50	25	12	16	20	50
K1829.05050001	50	smooth	500	25	12	20	16	17,5	11	M5	M6	50	25	12	16	20	50
K1829.05060001	50	smooth	600	25	12	20	16	17,5	11	M5	M6	50	25	12	16	20	50
K1829.05070001	50	smooth	700	25	12	20	16	17,5	11	M5	M6	50	25	12	16	20	50
K1829.05030002	50	serrated	300	25	12	20	16	17,5	11	M5	M6	50	25	12	16	20	50
K1829.05040002	50	serrated	400	25	12	20	16	17,5	11	M5	M6	50	25	12	16	20	50
K1829.05050002	50	serrated	500	25	12	20	16	17,5	11	M5	M6	50	25	12	16	20	50
K1829.05060002	50	serrated	600	25	12	20	16	17,5	11	M5	M6	50	25	12	16	20	50
K1829.05070002	50	serrated	700	25	12	20	16	17,5	11	M5	M6	50	25	12	16	20	50
K1829.07240001	72	smooth	400	25	16	26	16	17,5	11	M6	M6	72	40	15	23,5	30	65
K1829.07250001	72	smooth	500	25	16	26	16	17,5	11	M6	M6	72	40	15	23,5	30	65
K1829.07260001	72	smooth	600	25	16	26	16	17,5	11	M6	M6	72	40	15	23,5	30	65
K1829.07270001	72	smooth	700	25	16	26	16	17,5	11	M6	M6	72	40	15	23,5	30	65
K1829.07240002	72	serrated	400	25	16	26	16	17,5	11	M6	M6	72	40	15	23,5	30	65
K1829.07250002	72	serrated	500	25	16	26	16	17,5	11	M6	M6	72	40	15	23,5	30	65
K1829.07260002	72	serrated	600	25	16	26	16	17,5	11	M6	M6	72	40	15	23,5	30	65
K1829.07270002	72	serrated	700	25	16	26	16	17,5	11	M6	M6	72	40	15	23,5	30	65
K1829.10040001	100	smooth	400	25	16	26	16	17,5	11	M6	M8	72	42,6	15	23,5	40	100
K1829.10050001	100	smooth	500	25	16	26	16	17,5	11	M6	M8	72	42,6	15	23,5	40	100
K1829.10060001	100	smooth	600	25	16	26	16	17,5	11	M6	M8	72	42,6	15	23,5	40	100
K1829.10070001	100	smooth	700	25	16	26	16	17,5	11	M6	M8	72	42,6	15	23,5	40	100
K1829.10040002	100	serrated	400	25	16	26	16	17,5	11	M6	M8	72	42,6	15	23,5	40	100
K1829.10050002	100	serrated	500	25	16	26	16	17,5	11	M6	M8	72	42,6	15	23,5	40	100
K1829.10060002	100	serrated	600	25	16	26	16	17,5	11	M6	M8	72	42,6	15	23,5	40	100
K1829.10070002	100	serrated	700	25	16	26	16	17,5	11	M6	M8	72	42,6	15	23,5	40	100

Order No.	B	Version 1	L	F	G	NK =	NF =	NW =
				Socket head screw DIN 912	cap screw DIN 912	Quantity Wedge clamp	Quantity Fixed jaw	Quantity Workpieces
K1829.05030001	50	smooth	300	M10x30	M12x25	2	3	4

Multi-clamping system double-sided wedge clamps fixed jaw DS

Overview of items

Order No.	B	Version 1	L	F Socket head screw DIN 912	G cap screw DIN 912	NK = Quantity Wedge clamp	NF = Quantity Fixed jaw	NW = Quantity Workpieces
K1829.05040001	50	smooth	400	M10x30	M12x25	2	3	4
K1829.05050001	50	smooth	500	M10x30	M12x25	2	3	4
K1829.05060001	50	smooth	600	M10x30	M12x25	2	3	4
K1829.05070001	50	smooth	700	M10x30	M12x25	2	3	4
K1829.05030002	50	serrated	300	M10x30	M12x25	2	3	4
K1829.05040002	50	serrated	400	M10x30	M12x25	2	3	4
K1829.05050002	50	serrated	500	M10x30	M12x25	2	3	4
K1829.05060002	50	serrated	600	M10x30	M12x25	2	3	4
K1829.05070002	50	serrated	700	M10x30	M12x25	2	3	4
K1829.07240001	72	smooth	400	M14X1,5X50	M16x40	1	2	2
K1829.07250001	72	smooth	500	M14X1,5X50	M16x40	1	2	2
K1829.07260001	72	smooth	600	M14X1,5X50	M16x40	1	2	2
K1829.07270001	72	smooth	700	M14X1,5X50	M16x40	1	2	2
K1829.07240002	72	serrated	400	M14X1,5X50	M16x40	1	2	2
K1829.07250002	72	serrated	500	M14X1,5X50	M16x40	1	2	2
K1829.07260002	72	serrated	600	M14X1,5X50	M16x40	1	2	2
K1829.07270002	72	serrated	700	M14X1,5X50	M16x40	1	2	2
K1829.10040001	100	smooth	400	M14X1,5X50	M16x40	1	2	2
K1829.10050001	100	smooth	500	M14X1,5X50	M16x40	1	2	2
K1829.10060001	100	smooth	600	M14X1,5X50	M16x40	1	2	2
K1829.10070001	100	smooth	700	M14X1,5X50	M16x40	1	2	2
K1829.10040002	100	serrated	400	M14X1,5X50	M16x40	1	2	2
K1829.10050002	100	serrated	500	M14X1,5X50	M16x40	1	2	2
K1829.10060002	100	serrated	600	M14X1,5X50	M16x40	1	2	2
K1829.10070002	100	serrated	700	M14X1,5X50	M16x40	1	2	2