

## Elevating castors

with integrated machine foot

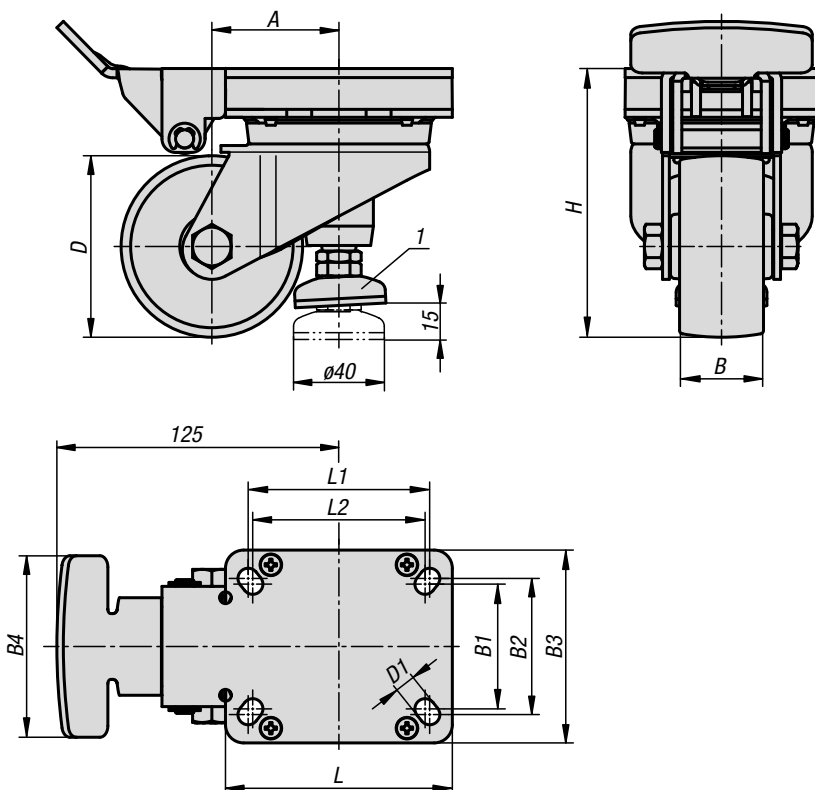
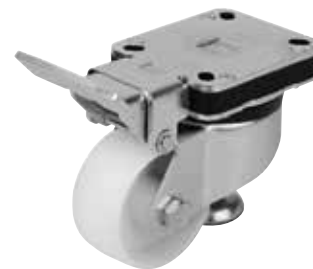

**Material:**

Housing steel plate.  
Roller break resistant polyamide 6, Shore 70D.  
Machine foot steel.

**Version:**

Housing trivalent blue passivated.  
Roller white.  
Machine foot electro zinc-plated with grey rubber pads.

**Sample order:**

K1787.08037

**Note:**

Elevating castor swivel version with integrated levelling machine foot. With sealed ball bearing in the swivel head. Wheel axle bolted. The ergonomic form of the non-swivelling actuating lever enables ease of operation. The short actuation travel with simultaneous long plunger stroke and very high lifting force enables heavy weights to be easily raised and safely fixated.

**Drawing reference:**

1) swivelling



**KIPP Elevating castors with integrated machine foot**

Order No.	Version 1	Wheel bearing	D	A	B	B1	B2	B3	B4	D1	H	L	L1	L2	Permissible load kg
K1787.08037	with locking system	plain bearing	80	56	37	55	60	80	85	9	120	100	80	76	230
K1787.10037	with locking system	plain bearing	100	65	37	55	60	80	85	9	142	100	80	76	230