

Swivel castors

compact version



Material:

Housing steel plate, trivalent blue passivated.
 Roller light brown polyurethane, Shore 92 A
 or white polyamide, Shore 80 D.

Version:

Housing press formed.
 Swivel castor housing with 2x ball bearing in the swivel head and ball shield.
 Roller with two pressed-in ball bearings.

Sample order:

K1774.0352701

Note:

Wheel axle bolted.

Polyurethane roller: low-noise, low rolling resistance, elastic, floor-protecting, very wear resistant, non-staining.

Polyamide roller: very low roll and pivot resistance, smooth running on smooth floors, very wear resistant.

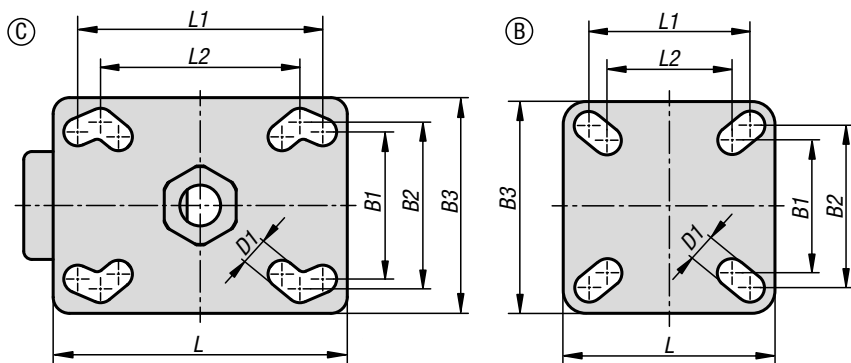
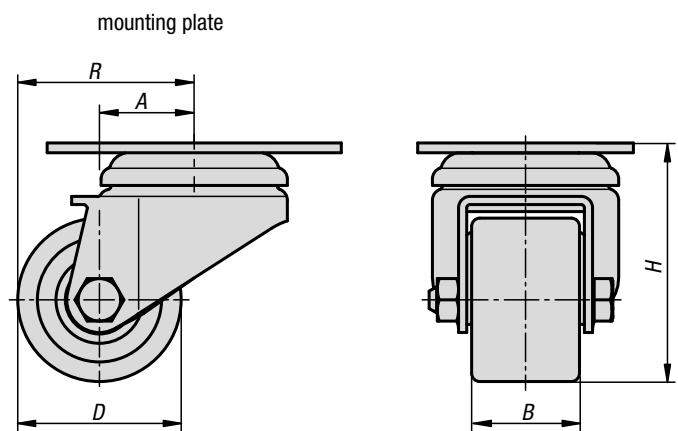
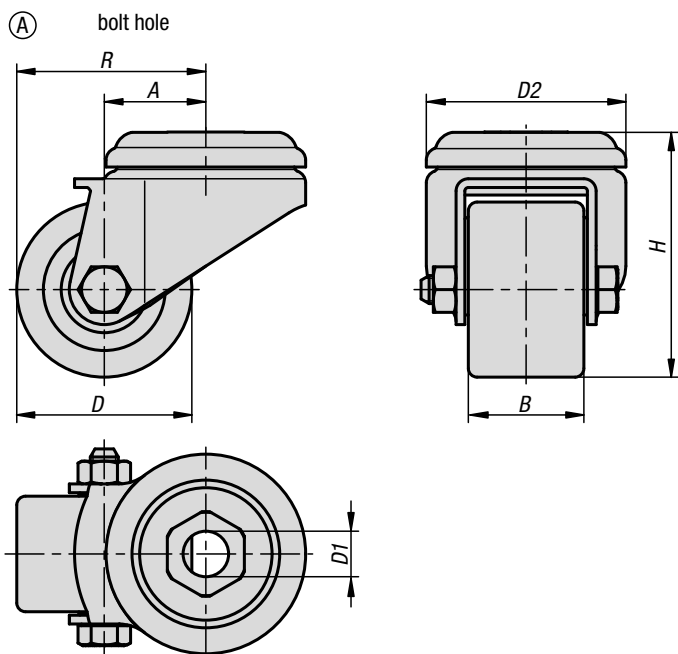

Swivel castors

compact version

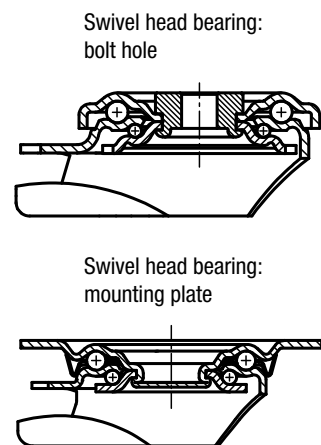

KIPP Swivel castors compact version

Order No.	Form	Item	Version 1	Wheel bearing	Material roller	A	B	B1	B2	B3	D	D1
K1774.0352701	A	Swivel castor	without locking system	ball bearing	polyurethane	15	27	-	-	-	35	11
K1774.0352802	A	Swivel castor	without locking system	ball bearing	polyamide	15	28	-	-	-	35	11
K1774.0503301	A	Swivel castor	without locking system	ball bearing	polyurethane	29	33	-	-	-	50	13
K1774.0503202	A	Swivel castor	without locking system	ball bearing	polyamide	29	32	-	-	-	50	13
K1774.0352711	B	Swivel castor	without locking system	ball bearing	polyurethane	15	27	38	48	60	35	6,2
K1774.0352812	B	Swivel castor	without locking system	ball bearing	polyamide	15	28	38	48	60	35	6,2
K1774.0503311	C	Swivel castor	without locking system	ball bearing	polyurethane	29	33	45	51	66	50	8,5
K1774.0503212	C	Swivel castor	without locking system	ball bearing	polyamide	29	32	45	51	66	50	8,5

Order No.	Form	Item	Version 1	Wheel bearing	Material roller	D2	H	L	L1	L2	R	Permissible load kg
K1774.0352701	A	Swivel castor	without locking system	ball bearing	polyurethane	43	50	-	-	-	32,5	100
K1774.0352802	A	Swivel castor	without locking system	ball bearing	polyamide	43	50	-	-	-	32,5	100
K1774.0503301	A	Swivel castor	without locking system	ball bearing	polyurethane	57	70	-	-	-	54	150
K1774.0503202	A	Swivel castor	without locking system	ball bearing	polyamide	57	70	-	-	-	54	150
K1774.0352711	B	Swivel castor	without locking system	ball bearing	polyurethane	-	52	60	48	38	32,5	100
K1774.0352812	B	Swivel castor	without locking system	ball bearing	polyamide	-	52	60	48	38	32,5	100
K1774.0503311	C	Swivel castor	without locking system	ball bearing	polyurethane	-	73	90	75	61	54	150
K1774.0503212	C	Swivel castor	without locking system	ball bearing	polyamide	-	73	90	75	61	54	150