

Swivel and fixed castors

heavy-duty version



swivel castor

fixed castor

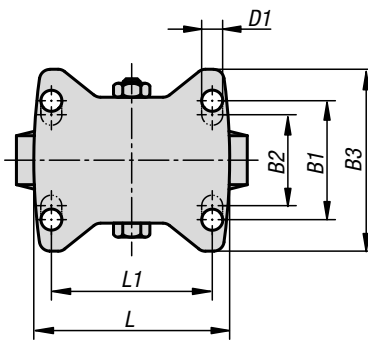
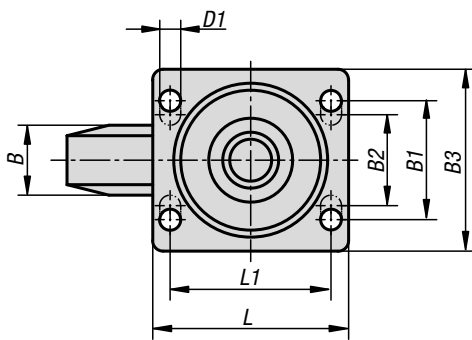
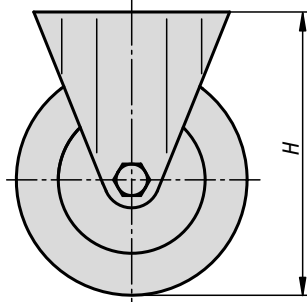
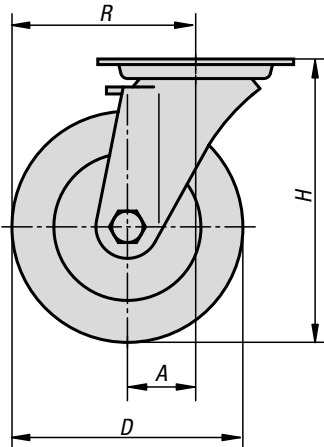

Material:

Housing thick steel plate.
Wheels PA 6.

Version:

Housing press formed.
Swivel castor housing with strong fork and base plate, very robust centre pin bolted and secured. The swivel head is additionally reinforced with specially formed and hardened bearing shells.
Plain bearings in the wheels.

Sample order:

K1771.12540

Note:

Wheel axle bolted. The wheels are particularly shock and impact proof and have high abrasion resistance.



swivel head bearing

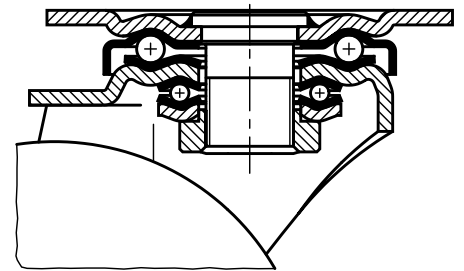

KIPP Swivel and fixed castors heavy-duty version

Order No. Fixed castor without locking system	Order No. Swivel castor without locking system	Order No. Swivel castor with stop-top locking system	Wheel bearing	A	B	B1	B2	B3	D	D1
K1771.100371	K1771.10037	K1771.100372	plain bearing	-/45/45	37	60	-	85	100	9
K1771.125401	K1771.12540	K1771.125402	plain bearing	-/45/45	40	60	-	85	125	9
K1771.150501	K1771.15050	K1771.150502	plain bearing	-/65/65	50	80	75	110	150	11
K1771.200501	K1771.20050	K1771.200502	plain bearing	-/70/70	50	80	75	110	200	11

Order No. Fixed castor without locking system	Order No. Swivel castor without locking system	Order No. Swivel castor with stop-top locking system	Wheel bearing	H	L	L1	R	Permissible load kg
K1771.100371	K1771.10037	K1771.100372	plain bearing	140	100	80	-/95/95	280
K1771.125401	K1771.12540	K1771.125402	plain bearing	165	100	80	-/107,5/107,5	300
K1771.150501	K1771.15050	K1771.150502	plain bearing	197	140	105	-/140/140	400
K1771.200501	K1771.20050	K1771.200502	plain bearing	245	140	105	-/170/170	600