

## Swivel and fixed castors

heavy-duty version



swivel castor

fixed castor

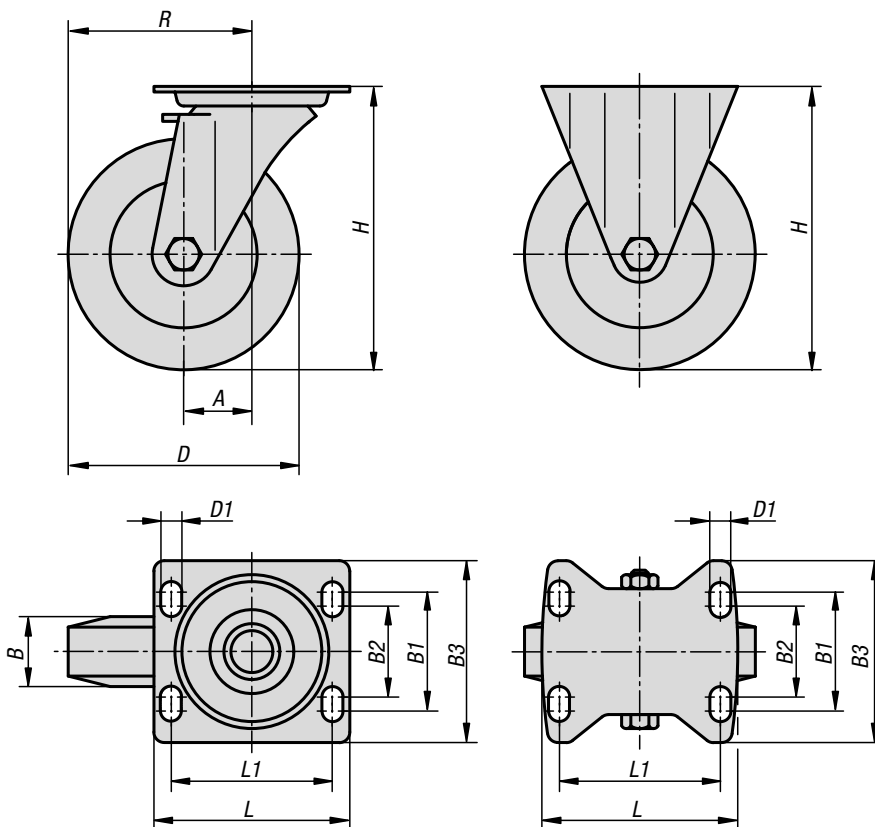

**Material:**

Housing thick steel plate.  
Wheels welded steel body and Extrathane® tread.

**Version:**

Housing press formed.  
Swivel castor housing with strong fork and base plate, very robust centre pin bolted and secured. The swivel head is additionally reinforced with specially formed and hardened bearing shells.

**Sample order:**

K1768.16050

**Note:**

These castors are particularly shock and impact proof. The treads resist abrasion and are elastic and low-noise. Wheel axle bolted.



swivel head bearing

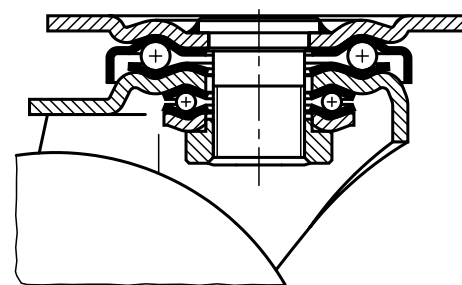

### KIPP Swivel and fixed castors heavy-duty version

Order No. Fixed castor without locking system	Order No. Swivel castor without locking system	Order No. Swivel castor with stop-top locking system	Wheel bearing	A	B	B1	B2	B3	D	D1
K1768.125501	K1768.12550	K1768.125502	ball bearing	-/55/55	50	80	75	110	125	11
K1768.160501	K1768.16050	K1768.160502	ball bearing	-/65/65	50	80	75	110	160	11
K1768.200501	K1768.20050	K1768.200502	ball bearing	-/70/70	50	80	75	110	200	11

Order No. Fixed castor without locking system	Order No. Swivel castor without locking system	Order No. Swivel castor with stop-top locking system	Wheel bearing	H	L	L1	R	Permissible load kg
K1768.125501	K1768.12550	K1768.125502	ball bearing	170	140	105	-/117,5/117,5	500
K1768.160501	K1768.16050	K1768.160502	ball bearing	202	140	105	-/145/145	700
K1768.200501	K1768.20050	K1768.200502	ball bearing	245	140	105	-/170/170	900