

Attachment jaws with prism for fixed jaws DS and ES

Item description/product images

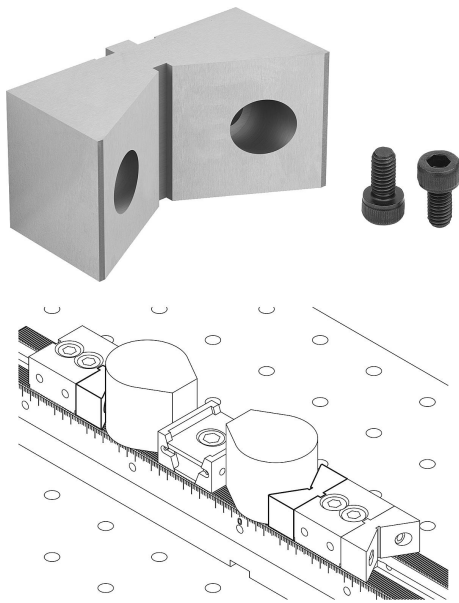

Description

Material:
Tool steel.

Version:
Hardened and ground (HRC 55).

Note:
Attachment jaws with prism are used for clamping round workpieces. With the longitudinal slot on the back, they can be aligned exactly on the ES and DS fixed jaws.

Application:
The attachment jaws with prism are screwed onto the ES and DS fixed stops.

Advantages:
The attachment jaws with prism ensure repeat accuracy when clamping workpieces.

Drawings

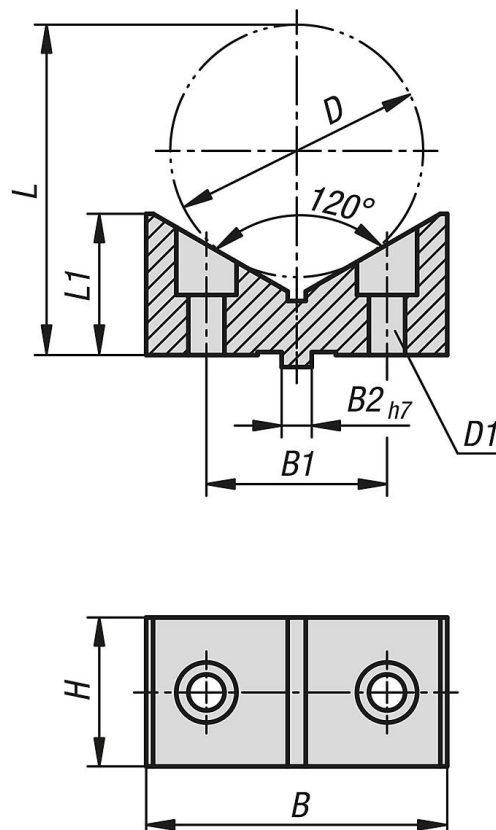

Overview of items

Attachment jaws with prism for fixed jaws DS and ES

Attachment jaws with prism for fixed jaws DS and ES

Overview of items

Order No.	suitable for system width	L	B	H	L1	B1	B2	D	max. clamping diameter	D1 for screw to DIN 912
K1754.05070	50	54,98	50	25	23,5	30	5	42	70	M5
K1754.072110	72	82,45	72	40	35	44	8	62	110	M6
K1754.100160	100	90,24	100	43	50	64	10	62	160	M8