

Locating cylinder stainless steel

pneumatic



By locating cylinder Form A, the clamping balls are pushed out by a spring. Compressed air is used to retract the balls.

By locating cylinder Form B, the clamping balls are initially retracted. Compressed air pushes the balls out.

Material:

Body, stainless steel.
Seal, NBR.

Version:

Stainless steel bright.

Sample order:

K1738.10140

Note for ordering:

Form A is marked with a groove.

Note:

The stated clamping and retaining forces are related to an operating pressure of 0.5 Mpa.

When using several positioning units, the distance tolerance of ± 0.1 mm should not be exceeded.

Repeat accuracy ± 0.2 mm.

Assembly:

Installation dimensions are for a 6 mm thick plate.

Accessories:

K1739 locating bushes stainless steel.

Drawing reference:

- 1) Form A ID groove
- 2) Pneumatic connection
- 3) Locating bush for locating cylinder
- 4) Form A locating cylinder
- 5) Form B locating cylinder

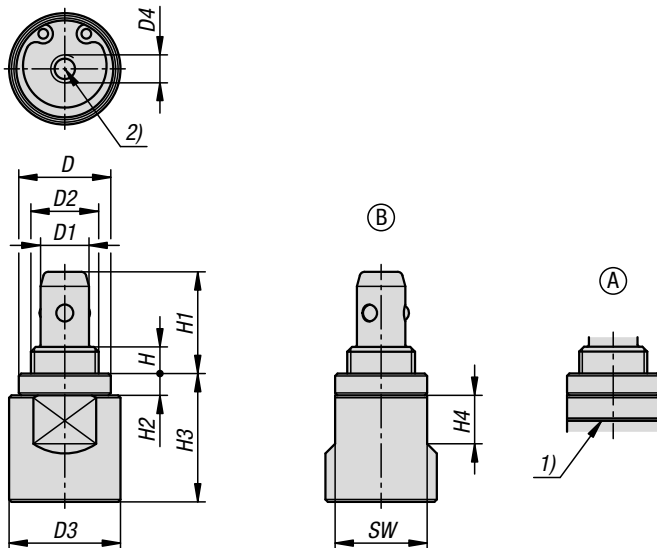

mounting instructions:

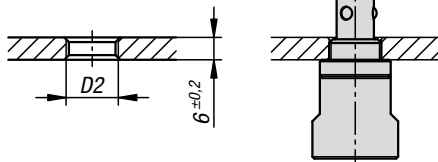

Locating cylinder stainless steel

pneumatic

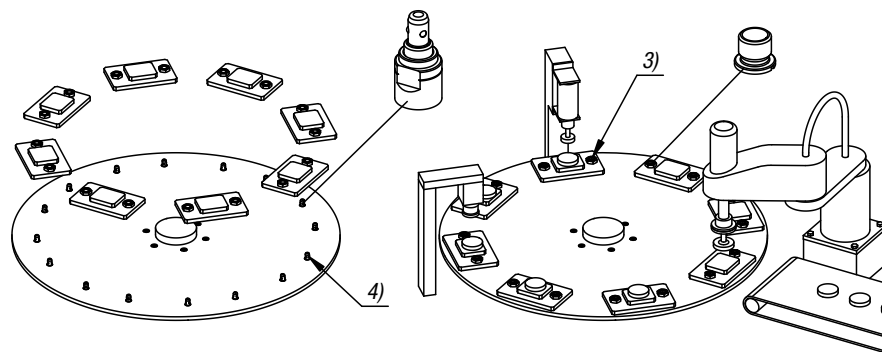
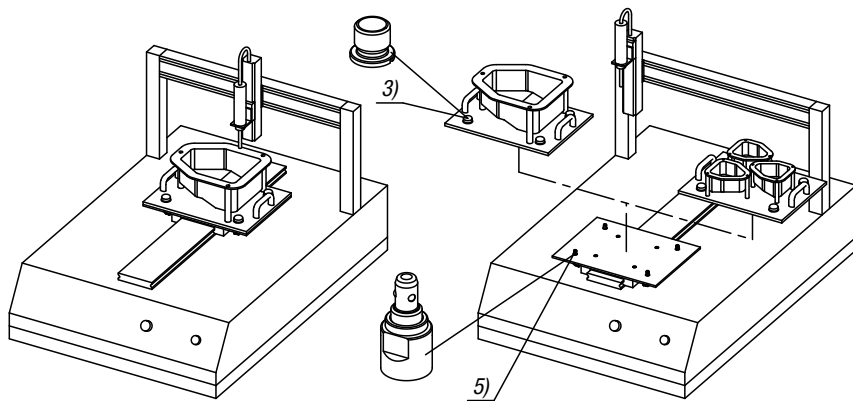

KIPP Locating cylinder stainless steel, pneumatic

Order No.	Form	Form-Type	D	D1	D2	D3	D4	H	H1	H2	H3	H4	SW	Operating pressure MPa	F N	Holding force N
K1738.10140	A	spring-loaded	19	10	M14x1	23	M5	5,5	21	4,5	26,5	10	19	0,3 - 0,7	50	150
K1738.10141	B	Clamped pneumatically	19	10	M14x1	23	M5	5,5	21	4,5	26,5	10	19	0,3 - 0,7	150	300