

Hoist rings, steel, 360° rotation

grade 10

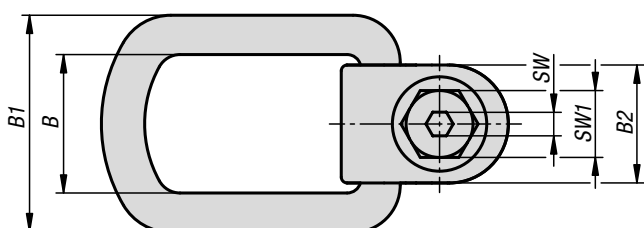
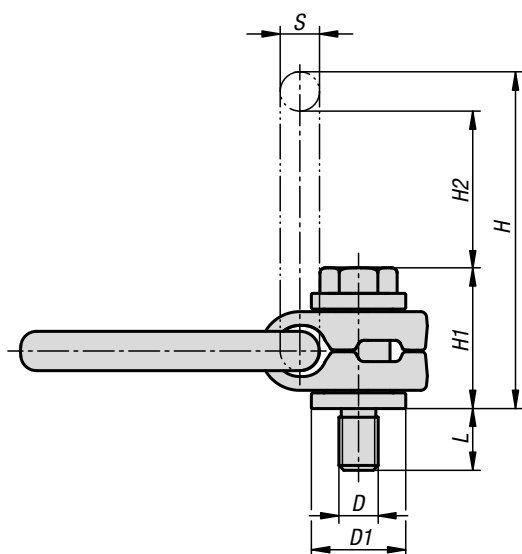

Material:

Ring and attachment shackle steel.
Bolt and bushing steel.

Version:

Ring and shackle forged, hardened and tempered.
100% electromagnetic crack detection, painted blue.
Bolt grade 10.9 or higher. 100% electromagnetic crack detection.
Bush electro zinc-plated.

Sample order:

K1735.12020

Note:

The hoist ring can be folded-down, rotates through 360° and bears the full load in any permitted loading direction. The nominal load capacity is visibly indicated on the hoist ring. It applies to the most unfavourable load case (see table). The test load is 2.5 times the safe working load (SWL). The specified working load limit must not be exceeded.

With captive but removable hex bolt. The hoist rings comply with the Machinery Directive and are DGUV tested.

Tested according to DIN EN 1677-1.

The CE marking is stamped into the hoist ring.

On request:

Certificate of conformity.

Hoist rings, steel, 360° rotation

grade 10



Maximum lifting weight "G" in kg for different sling types

Sling configuration																				
	No. of slings	1	1	2	2	2	2	2	2	3 - 4	3 - 4	3 - 4	3 - 4	3 - 4	3 - 4	3 - 4	3 - 4	3 - 4	3 - 4	
sling angle α	0°	90°	0°	90°	0°-45°	45°-60°	asymmetric	0°-45°	45°-60°	asymmetric	0°-45°	45°-60°	asymmetric	0°-45°	45°-60°	asymmetric	0°-45°	45°-60°	asymmetric	
M8	300	300	600	600	420	300	300	640	450	300	640	450	300	640	450	300	640	450	300	
M10	630	630	1260	1260	890	630	630	1340	950	630	1340	950	630	1340	950	630	1340	950	630	
M12	1000	1000	2000	2000	1410	1000	1000	2120	1500	1000	2120	1500	1000	2120	1500	1000	2120	1500	1000	
M16	1500	1500	3000	3000	2120	1500	1500	3180	2250	1500	3180	2250	1500	3180	2250	1500	3180	2250	1500	
M20	2500	2500	5000	5000	3540	2500	2500	5300	3750	2500	5300	3750	2500	5300	3750	2500	5300	3750	2500	
M24	4000	4000	8000	8000	5660	4000	4000	8480	6000	4000	8480	6000	4000	8480	6000	4000	8480	6000	4000	
M30	5000	5000	10000	10000	7070	5000	5000	10610	7500	5000	10610	7500	5000	10610	7500	5000	10610	7500	5000	
M36	8000	8000	16000	16000	11310	8000	8000	16970	12000	8000	16970	12000	8000	16970	12000	8000	16970	12000	8000	

KIPP Hoist rings, steel, 360° rotation, grade 10

Order No.	B	B1	B2	D	D1	H	H1	H2	L	S	SW	SW1	max. permissible load kg	Tightening torque Nm
K1735.08011	36	57	30	M8	24	87	34	41	11	12	6	13	300	20
K1735.10016	36	57	30	M10	24	87	35	40	16	12	6	17	630	30
K1735.12020	36	57	34	M12	30	98	43	41	20	14	8	19	1000	45
K1735.16025	36	57	34	M16	30	98	46	39	25	14	10	24	1500	150
K1735.20032	53	83	50	M20	45	145	56	71	32	17	12	30	2500	300
K1735.24037	53	83	50	M24	45	145	59	69	37	17	14	36	4000	400
K1735.30044	64	101	67	M30	59	172	85	64	44	23	17	46	5000	1000
K1735.36053	84	126	78	M36	69	223	100	96	53	28	22	55	8000	1800