

## T-slot clamp

with cam

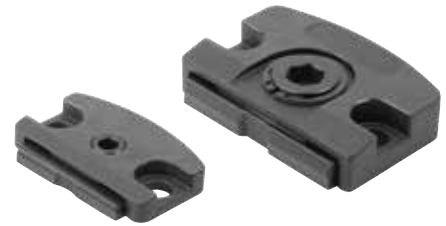
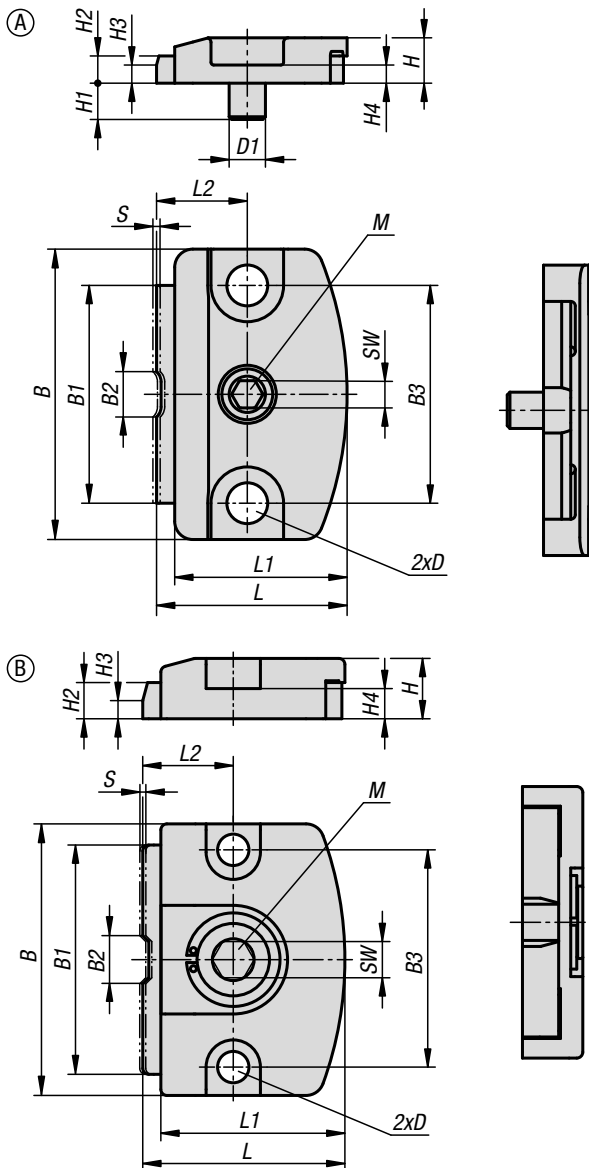

**Material:**  
Carbon steel.

**Version:**  
Black oxidised.

**Sample order:**  
K1696.10400

**Note:**  
Form A with locating pin.  
Form B without locating pin.

**Assembly:**  
See drawing (Form A).

**Advantages:**  
- Compact and flat design  
- Quick and easy clamping of components

### mounting instructions:

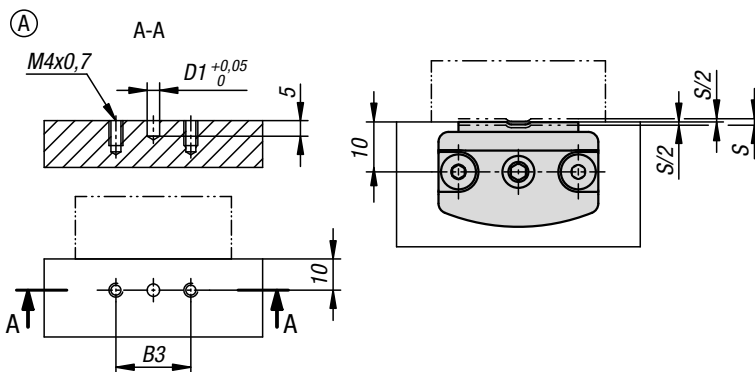

### KIPP T-slot clamp with cam

Order No.	Form	B	B1	B2	B3	D	D1	H	H1	H2	H3	H4	L	L1	L2	SW	Travel S	Clamping force kN	Tightening torque max. Nm
K1696.00130	A	32	24	5	24	4,5	4	5	4	3	2	2	21	19	10	3	0,8	1,3	2,1
K1696.10400	B	45	38	8	36	5,2	-	10	-	6	3	5	33,5	30,5	15	6	1	4	10
K1696.10600	B	70	60	12	55	8,2	-	15	-	9	5	7	50	46	22	10	2	6	27