

Bowden cables

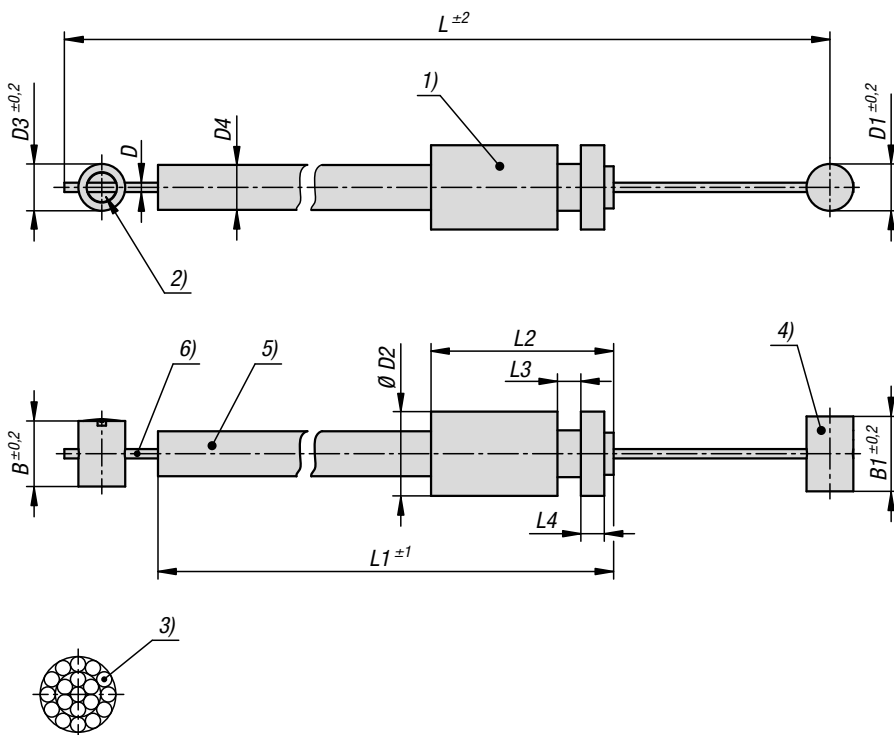

Drawing reference:

- 1) Sleeve
- 2) Screw nipple
- 3) Body 1x19
- 4) Nipple
- 5) Sheath
- 6) Wire cable

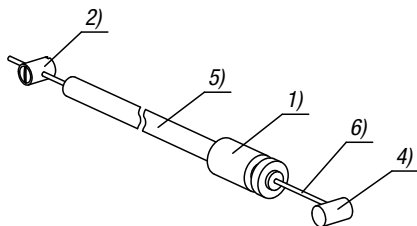

Material:

Wire cable stainless steel.
 Sheath, steel wire with inner and outer plastic coating.
 Sleeve POM.
 Nipple Zamac.
 Screw nipple steel.

Version:

Bowden cable sheath and sleeve black.
 Screw nipple electro zinc-plated.

Sample order:

K1646.11X10500

Note:

Bowden cables transfer the traction force and are used in combination with a release as a remote control. There are different lengths available to select from. The Bowden cable can be shortened as required during installation to ensure a perfect fit in the respective application.

Note the following points when installing Bowden cables:

The length of the free end of the cable can change due to layout angle, bend radius and load factors.

When laying the cable, take particular care to ensure that the bend radius is not below the minimum value, which in this case is $R = 65 \text{ mm}$. A too small radius can lead to increased wear and higher friction. During installation, avoid bending the cable more than the minimum value as this can cause damage to the casing. Also, the casing is designed only to support pressure forces. If pulled too sharply, the inner coil will be stretched and permanently damaged.

Tensile strength 1000 N max.

Supplied with:

Wire cable with nipple, sheath, sleeve and screw nipple.

Accessories:

Remote release K1481.

KIPP Bowden cables

Order No.	B	B1	D	D1	D2	D3	D4	L	L1	L2	L3	L4
K1646.11X0500	7	8	1,5	5	9	5	4,8	500	464,4	19,5	2,5	2,5
K1646.11X1000	7	8	1,5	5	9	5	4,8	1000	964,4	19,5	2,5	2,5