

Clamping levers, zinc

with female thread and clamping force intensifier

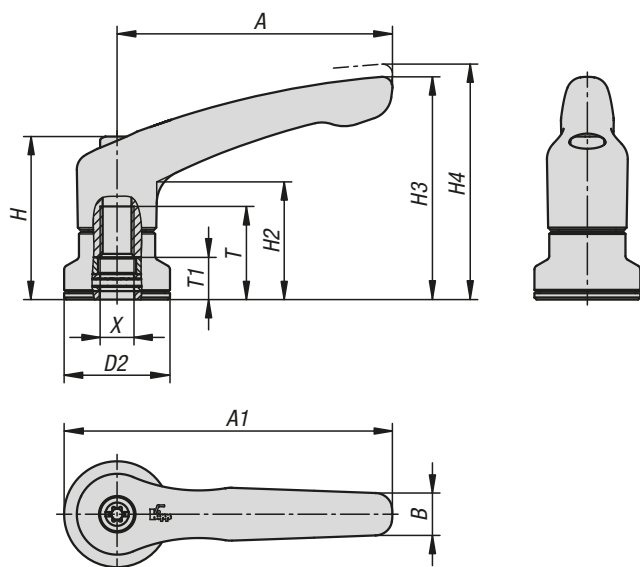

By using clamping levers with integrated clamping force intensifier, the clamping force can be increased by up to 75% compared to standard clamping levers.

Furthermore, this product can also be used by persons with limited hand strength (e.g. in rehabilitation) to achieve comparable clamping forces with less effort. Less effort is also needed to loosen the clamping lever.

The increase in clamping force is achieved by the integral needle roller thrust bearing, which generates very low surface friction on a rigid contact surface during clamping. The hardened thrust washers are designed for high clamping forces and the bearing with its high load rating guarantees a long service life.

The clamped component is permanently protected by the large, stationary contact surface. A washer is no longer required.

Material:

Handle die-cast zinc DIN EN 12844.

Steel parts grade 5.8.

Version:

Handle plastic-coated or high-gloss trivalent passivated

Steel parts, black oxidised.

Axial needle bearing with hardened and ground thrust washer.

Sample order:

K1599.5121 (clamping lever, black satin finish)

Note:

Δ Add the desired lever colour here.

Standard colours are:

black satin finish, orange RAL 2004, ruby red RAL 3003, silver metallic, high gloss chromed.

Method of operation:

In the default position, the handle is engaged with the threaded insert through a toothed ring. By lifting the handle, it can be repositioned and re-engaged in the toothed ring by spring force.

Application:

Machine, equipment and plant construction, rehabilitation sector.

Advantages:

Significant increase of the clamping force with the same tightening torque.

High quality axial needle bearing with high load rating and long service life.

The component surface is protected by the stationary lower ring.

On request:

Other colours.

Clamping levers, zinc

with female thread and clamping force intensifier



KIPP Clamping levers, zinc with female thread and clamping force intensifier

Order No.	X	D2	H	H2	H3	H4	A	A1	B	T	T1
K1599.208 Δ	M8	25	38,5	27,7	52,6	55,6	65	77,5	10	22	10
K1599.310 Δ	M10	30	47	33,9	64,4	68,6	80	95	11,2	24	10
K1599.410 Δ	M10	30	53,1	37,2	72,8	77,3	95	110	13,2	27	10
K1599.512 Δ	M12	35	59,1	41,9	83	87,5	110	127,5	15,4	33	10
K1599.310 Δ	M10	30	47	33,9	4,4	68,6	80	95	11,2	24	10

Clamping levers, zinc

with male thread and clamping force intensifier



By using clamping levers with integrated clamping force intensifier, the clamping force can be increased by up to 75% compared to standard clamping levers.

Furthermore, this product can also be used by persons with limited hand strength (e.g. in rehabilitation) to achieve comparable clamping forces with less effort. Less effort is also needed to loosen the clamping lever.

The increase in clamping force is achieved by the integral needle roller thrust bearing, which generates very low surface friction on a rigid contact surface during clamping. The hardened thrust washers are designed for high clamping forces and the bearing with its high load rating guarantees a long service life.

The clamped component is permanently protected by the large, stationary contact surface. A washer is no longer required.

Due to the modular construction many special designs are available.

Material:

Handle die-cast zinc DIN EN 12844.
Steel parts grade 5.8.

Version:

Handle plastic-coated or high-gloss trivalent passivated
Steel parts, black oxidised.
Axial needle bearing with hardened and ground thrust washer.

Sample order:

K1599.5121X20
(clamping lever, black satin finish; include length L)

Note:

Δ Add the desired lever colour here.
Standard colours are:
black satin finish, orange RAL 2004, ruby red RAL 3003,
silver metallic, high gloss chromed.

Method of operation:

In the default position, the handle is engaged with the threaded insert through a toothed ring. By lifting the handle, it can be repositioned and re-engaged in the toothed ring by spring force.

Application:

Machine, equipment and plant construction, rehabilitation sector.

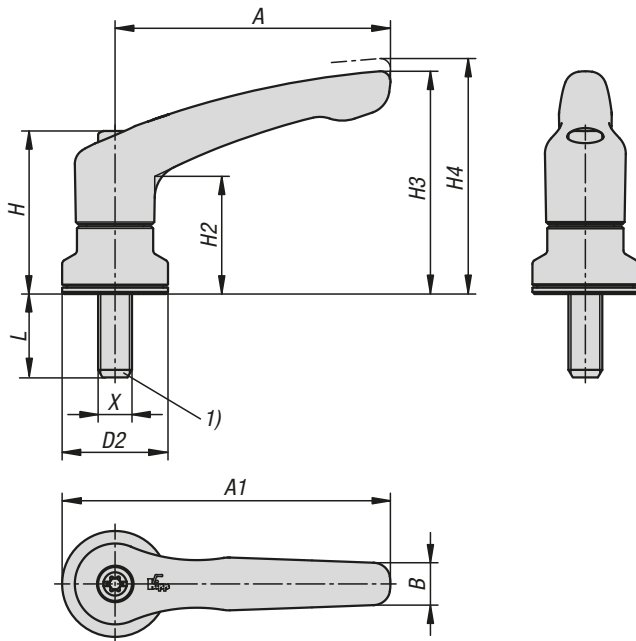

Clamping levers, zinc

with male thread and clamping force intensifier



Advantages:

Significant increase of the clamping force with the same tightening torque.
High quality axial needle bearing with high load rating and long service life.
The component surface is protected by the stationary lower ring.

On request:

Other colours and thread lengths.

Drawing reference:

1) flat point DIN EN ISO 4753



KIPP Clamping levers, zinc with male thread and clamping force intensifier

Order No.	X	D2	H	H2	H3	H4	A	A1	B	L
K1599.208 Δ X	M8	25	38,5	27,7	52,6	55,6	65	77,5	10	10/20/30/40
K1599.310 Δ X	M10	30	47	33,9	64,4	68,6	80	95	11,2	15/30/40/50
K1599.410 Δ X	M10	30	53,1	37,2	72,8	77,3	95	110	13,2	20/30/40/50
K1599.512 Δ X	M12	35	59,1	41,9	83	87,5	110	127,5	15,4	20/30/40/50