

# Clamping levers plastic

with female thread and clamping force intensifier



By using clamping levers with integrated clamping force intensifier, the clamping force can be increased by up to 75% compared to standard clamping levers.

Furthermore, this product can also be used by persons with limited hand strength (e.g. in rehabilitation) to achieve comparable clamping forces with less effort. Less effort is also needed to loosen the clamping lever.

The increase in clamping force is achieved by the integral needle roller thrust bearing, which generates very low surface friction on a rigid contact surface during clamping. The hardened thrust washers are designed for high clamping forces and the bearing with its high load rating guarantees a long service life.

The clamped component is permanently protected by the large, stationary contact surface. A washer is no longer required.

#### Material:

Handle fibreglass reinforced plastic with die-cast zinc toothed ring.  
Steel parts stainless steel 1.4305.

#### Version:

Steel parts bright.  
Axial needle bearing with hardened and ground thrust washer.

#### Sample order:

K1598.20886 (lever colour signal green)

#### Note:

Δ Add the desired grip colour here.

#### Method of operation:

The handle lever is engaged in the toothed insert by means of a toothed ring when not actuated, enabling the thread to be tightened or loosened. By lifting the handle, it can be repositioned and re-engaged in the toothed ring by spring force.

#### Application:

Machine, equipment and plant construction, rehabilitation sector.

#### Advantages:

Significant increase of the clamping force with the same tightening torque.  
High quality axial needle bearing with high load rating and long service life.  
The component surface is protected by the stationary lower ring.

#### On request:

Other colours.

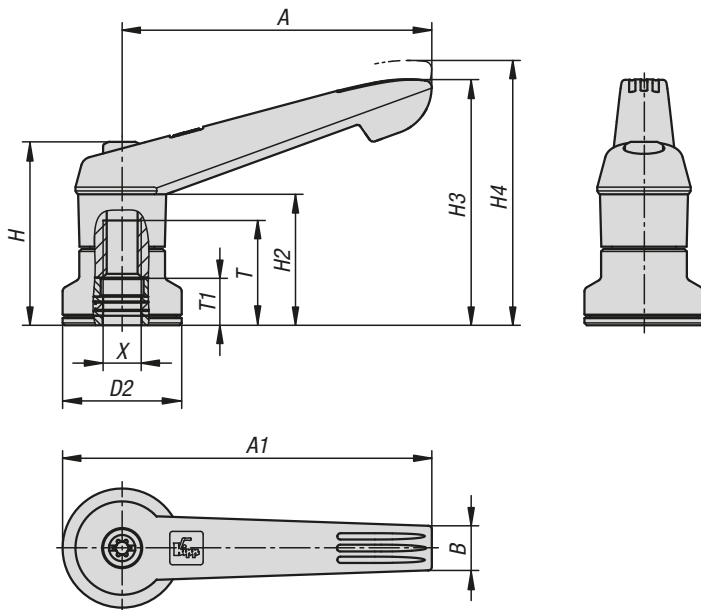

## Clamping levers plastic

with female thread and clamping force intensifier



### KIPP Clamping levers, plastic with female thread and clamping force intensifier

Order No.	X	D2	H	H2	H3	H4	A	A1	B	T	T1
K1598.208Δ	M8	25	38,5	27,5	51,6	55,6	65	77,5	9,4	22	10
K1598.310Δ	M10	30	47	34	63,4	67,9	80	95	11,1	24	10
K1598.410Δ	M10	30	53,1	36	71,1	76,1	95,4	110,4	13,2	27	10
K1598.512Δ	M12	35	59,1	43	82,8	87,8	109,9	127,4	15,6	33	10

# Clamping levers plastic

with male thread and clamping force intensifier

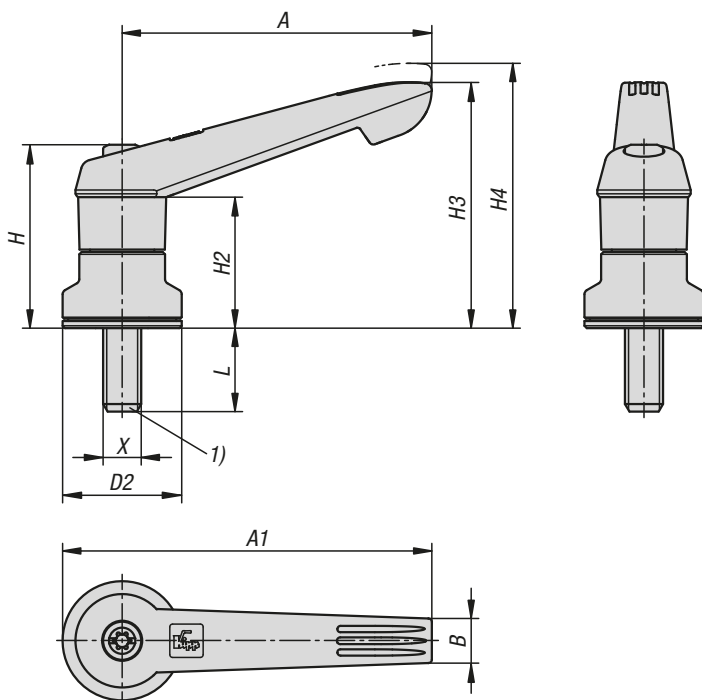

By using clamping levers with integrated clamping force intensifier, the clamping force can be increased by up to 75% compared to standard clamping levers.

Furthermore, this product can also be used by persons with limited hand strength (e.g. in rehabilitation) to achieve comparable clamping forces with less effort. Less effort is also needed to loosen the clamping lever.

The increase in clamping force is achieved by the integral needle roller thrust bearing, which generates very low surface friction on a rigid contact surface during clamping. The hardened thrust washers are designed for high clamping forces and the bearing with its high load rating guarantees a long service life.

The clamped component is permanently protected by the large, stationary contact surface. A washer is no longer required.

Due to the modular construction many special designs are available.

**Material:**

Handle fibreglass reinforced plastic with die-cast zinc toothed ring.  
Steel parts stainless steel 1.4305.

**Version:**

Steel parts bright.  
Axial needle bearing with hardened and ground thrust washer.

**Sample order:**

K1598.2081X40 (lever black grey; include length L)

**Note:**

Δ Add the desired grip colour here.

**Method of operation:**

The handle lever is engaged in the toothed insert by means of a toothed ring when not actuated, enabling the thread to be tightened or loosened. By lifting the handle, it can be repositioned and re-engaged in the toothed ring by spring force.

**Application:**

Machine, equipment and plant construction, rehabilitation sector.

## Clamping levers plastic

with male thread and clamping force intensifier



**Advantages:**

Significant increase of the clamping force with the same tightening torque.  
 High quality axial needle bearing with high load rating and long service life.  
 The component surface is protected by the stationary lower ring.

**On request:**

Special versions.  
 Other colours and thread lengths.

**Drawing reference:**

1) flat point DIN EN ISO 4753



**KIPP Clamping levers, plastic with male thread and clamping force intensifier**

Order No.	X	D2	H	H2	H3	H4	A	A1	B	L
K1598.512ΔX	M12	35	59,1	43	82,8	87,8	109,9	127,4	15,6	20/50/40/30
K1598.410ΔX	M10	30	53,1	36	71,1	76,1	95,4	110,4	13,2	50/20/40/30
K1598.208ΔX	M8	25	38,5	27,5	51,6	55,6	65	77,5	9,4	10/20/30/40
K1598.310ΔX	M10	30	47	34	63,4	67,9	80	95	11,1	15/30/40/50