

Toggle presses for pneumatic operation



Material:

Press uprights cast steel.
For pneumatic push-pull clamps, see K1549.

Version:

Press uprights painted blue.
For pneumatic push-pull clamps, see K1549.

Sample order:

K1551.06000

Note:

Double-acting cylinder without end position damping.
Pneumatic push-pull clamps can be reordered as a complete assembly kit. For technical data and clamping forces, see K1549.

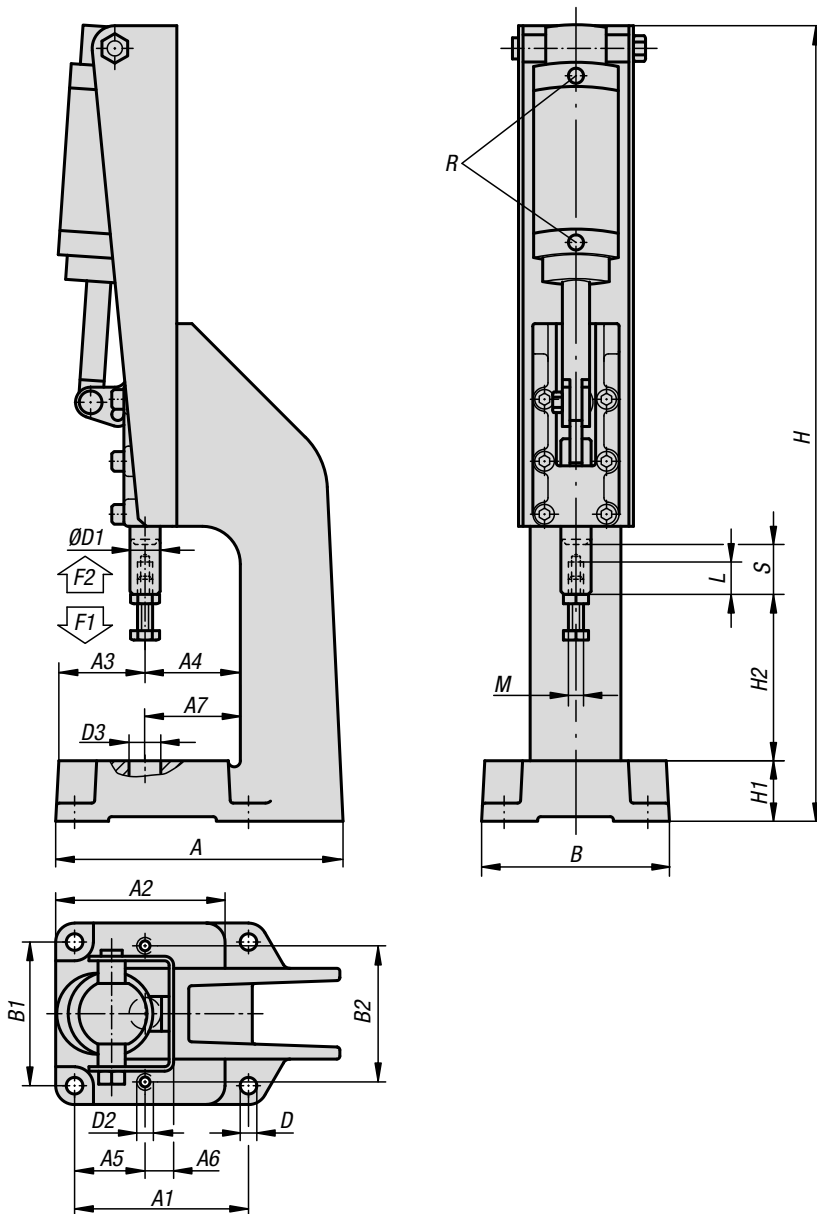

KIPP Toggle presses for pneumatic operation

Order No.	Clamping force F1 N	Retaining force F2 N	Operating pressure bar	Air consumption per cycle	strokes per min. at 6 bar
K1551.06000	3000	6000	2 - 6	0,04 dm ³	60
K1551.12000	5000	12000	2 - 6	0,1 dm ³	50
K1551.25000	7000	25000	2 - 6	0,25 dm ³	40

Order No.	A	A1	A2	A3	A4	A5	A6	A7	B	B1	B2	D	D1	D2	D3	H	H1	H2	L	M	R	Travel S
K1551.06000	157	95	95	53,9	46	46,5	12	44	105	80	70	9	14	M8	15,5	412	32	96	30	M8	G1/8	25
K1551.12000	210	115	113	59	63	49,6	18	60	126	95	80	11	19,9	M10	20	575	40	155	40	M10	G1/8	32
K1551.25000	238	145	139	61	79	52	22	75	150	125	90	11	25	M10	30	747	50	222	60	M12	G1/8	50