

Pneumatic push-pull clamps

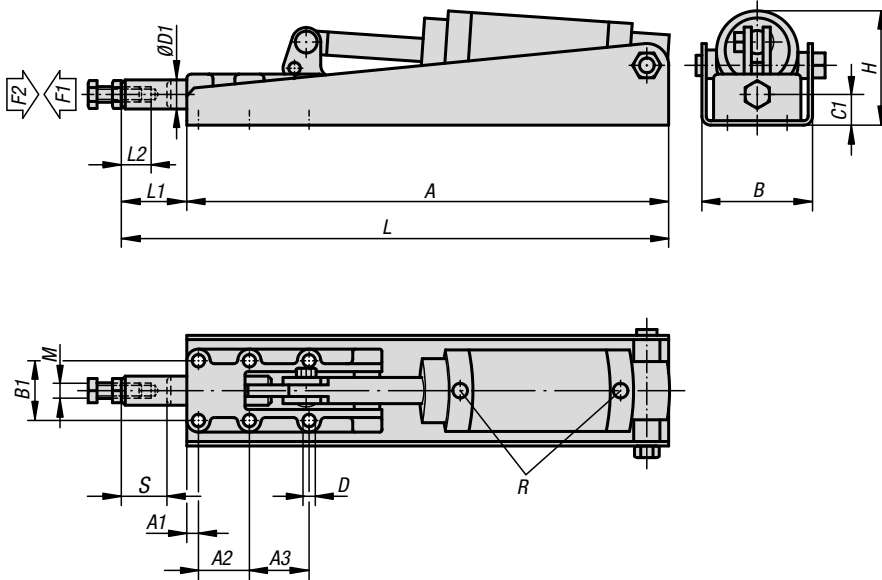
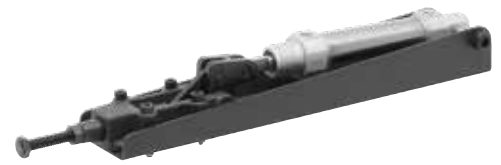

Material:

Lever parts, bracket and thrust rod, steel.
Thrust rod housing ductile iron (SG iron)

Version:

Phosphated. Cylinder bright.

Sample order:

K1549.06000

Pneumatic cylinder:

Double-acting without end of stroke dampening.

KIPP Pneumatic push-pull clamps

Order No.	Thrust rod extended / Clamping force F1 N	Retaining force F2 N	Air consumption per cycle	Operating pressure bar	strokes per min. at 6 bar
K1549.06000	5mm/300N, 10mm/400N, 15mm/600N, 20mm/800N, 24mm/1500N	6000	0,04 dm ³	2 - 6	60
K1549.12000	5mm/1200N, 10mm/1400N, 15mm/1600N, 20mm/1800N, 25mm/2300N, 30mm/4000N	12000	0,1 dm ³	2 - 6	50
K1549.25000	5mm/1400N, 10mm/1600N, 20mm/2000N, 30mm/2400N, 40mm/3000N, 49mm/7000N	25000	0,25 dm ³	2 - 6	40

Order No.	A	A1	A2	A3	B	B1	C1	D	D1	H	L	L1	L2	M	R	Travel S
K1549.06000	284	25	36,5	-	59	33,4	14	5,5	14	46,2	325	41	30	M8	G1/8	25
K1549.12000	380	8	35	41	76,5	41	21	8,5	19,9	66,5	435	55	40	M10	G1/8	32
K1549.25000	475	12	45	45	96	54	26	10,3	25	94,5	577	102	60	M12	G1/8	50